

MERKUR²

MANUAL FOR THE IMPLEMENTATION
OF SHAPED ROUTE ELEMENTS



ARKYS

GENERAL SHAPING INSTRUCTIONS

general information and instructions p. 3

BASIC ELEMENTS SHAPING ON A PLAIN

wire mesh tray width 50 mm p. 4

wire mesh tray width 100 mm p. 5

wire mesh tray width 150 mm p. 6

wire mesh tray width 200 mm p. 7

wire mesh tray width 250 mm p. 8

wire mesh tray width 300 mm p. 9

wire mesh tray width 400 mm p. 10

wire mesh tray width 500 mm p. 11

ROUTE CROSSINGS

wire mesh tray width 50, 100 mm p. 12

wire mesh tray width 150 - 500 mm p. 12

SPATIAL SHAPING

side wall height 50, 100 mm p. 13

spatial passing on routes p. 13

CONNECTING ROUTES

connecting routes of varying width p. 14

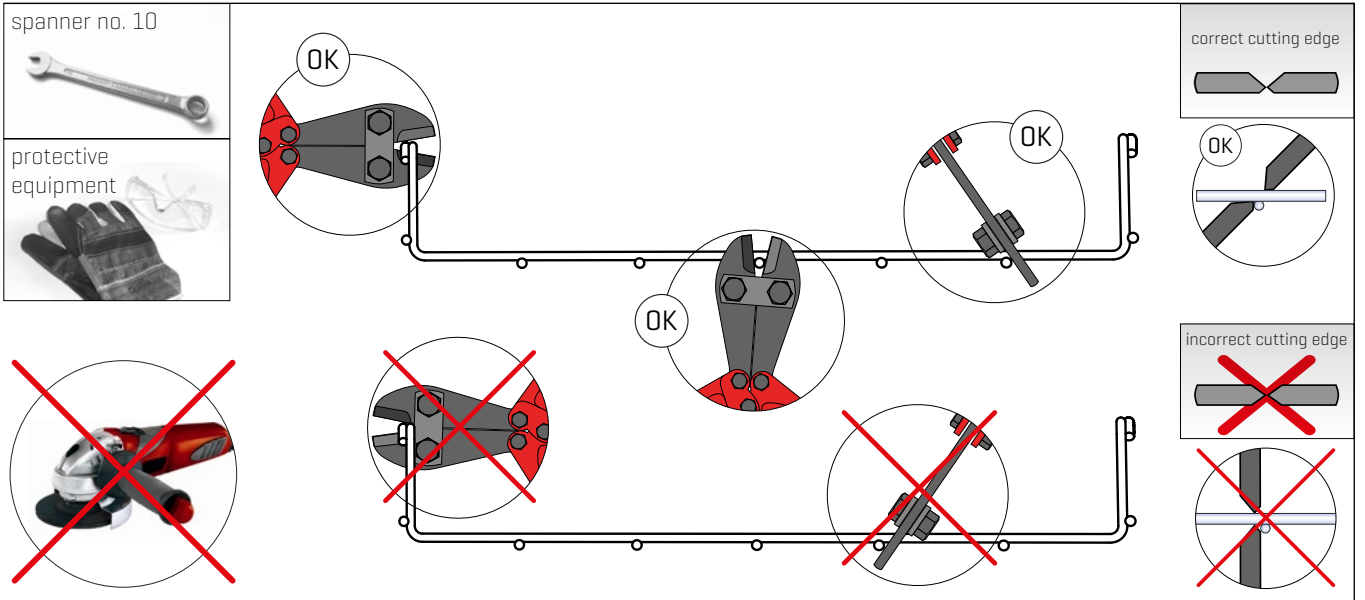

It is always necessary to use suitable anchoring elements [see MERKUR accessories] before and after the shaped section in order to achieve the declared load-bearing capacity of the cable routes.

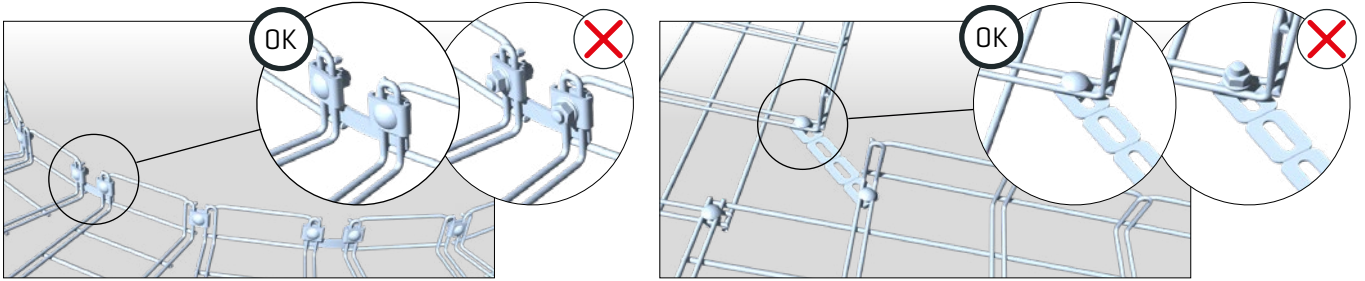

THE USED ELEMENTS AND ACCESSORIES

SZM 4 profile coupling

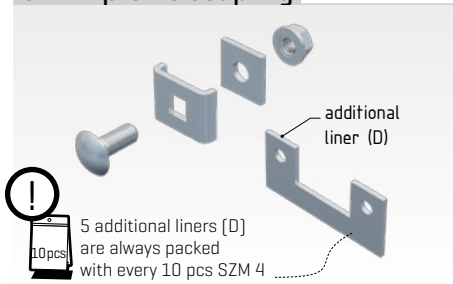

TPM 1000 shaping tape

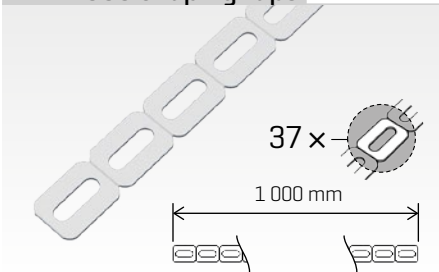

SPM 1 connecting set

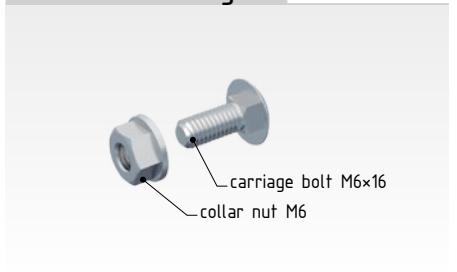

SZM 1 tray coupling

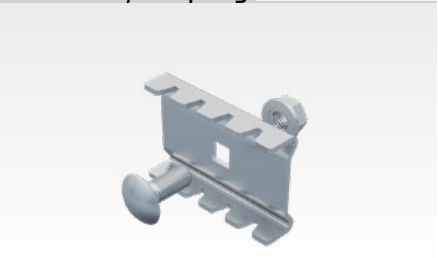

SZM 1-R tray coupling

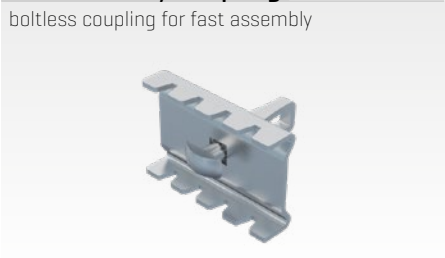

OK 1 protective cap for wires

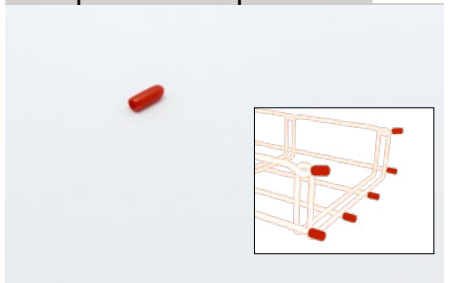

MERKUR bolt cutter

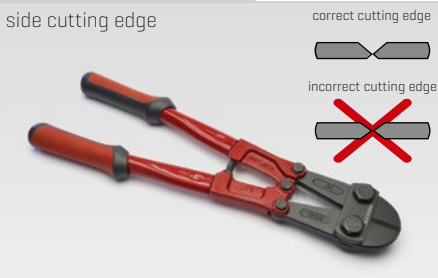

zinc spray - zinc 98% (400 ml)



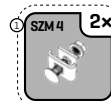
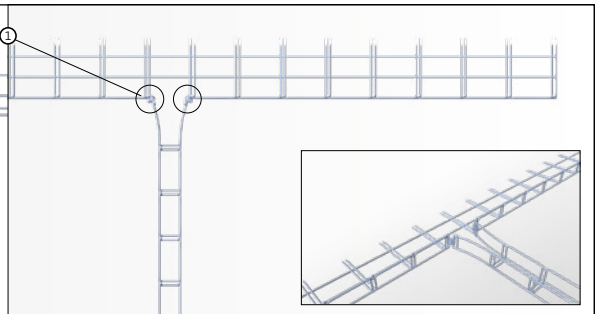
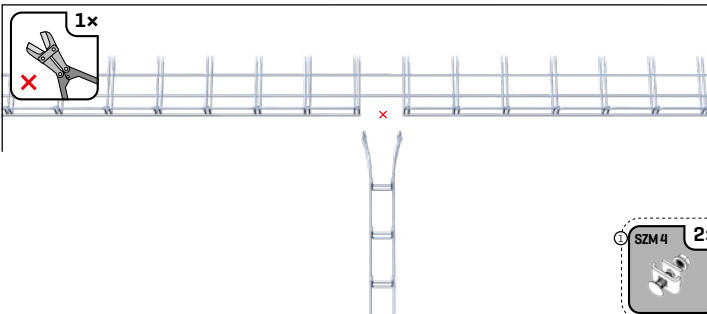
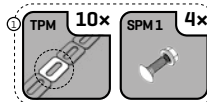
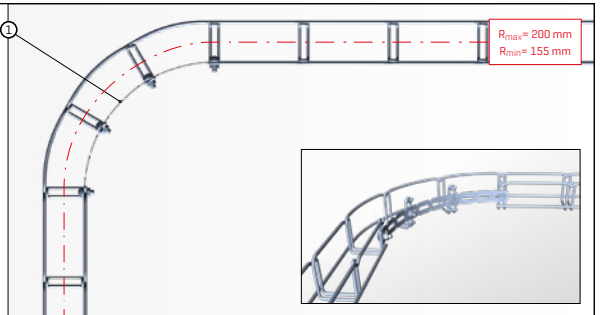
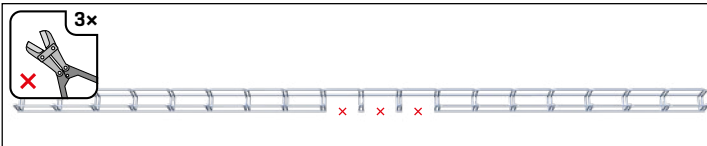
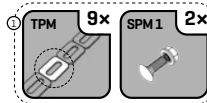
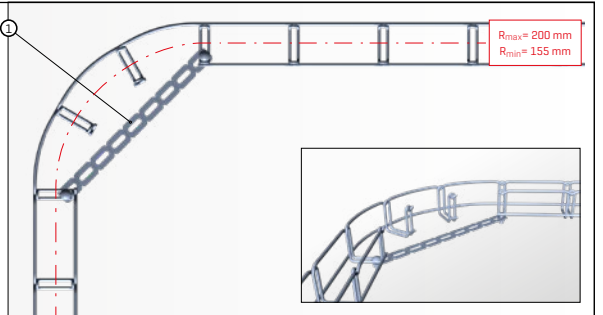
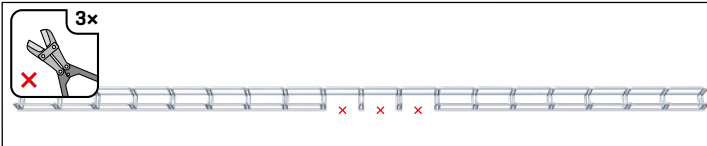
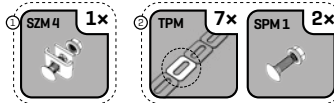
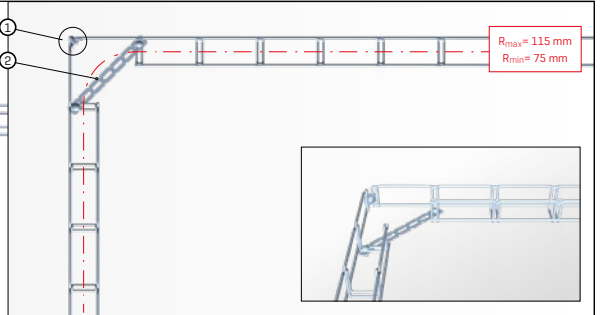
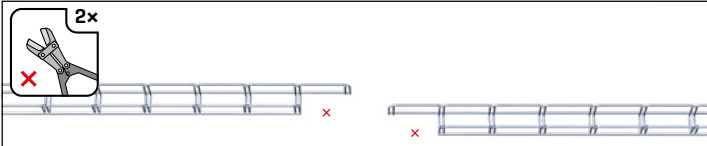
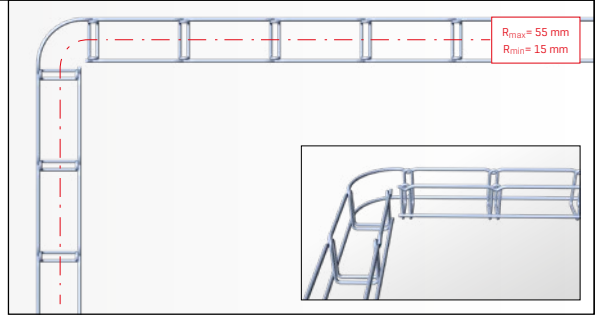
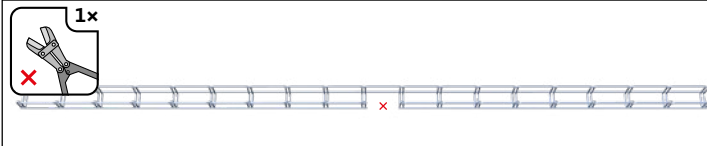

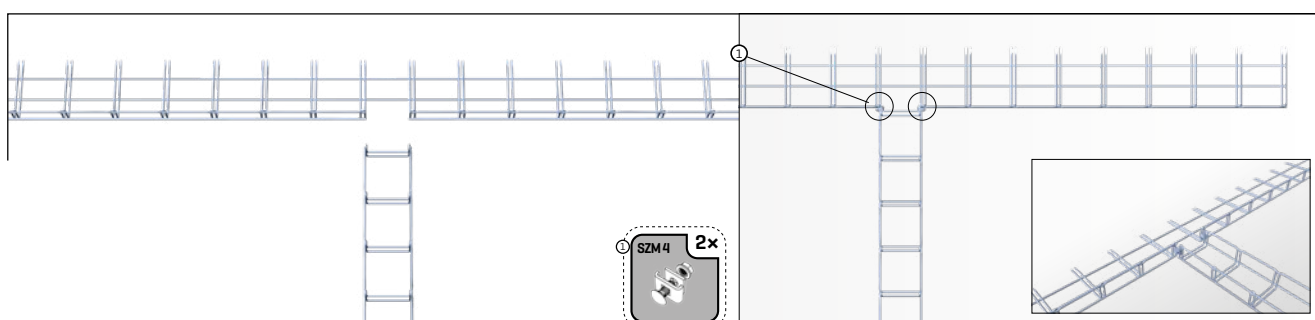
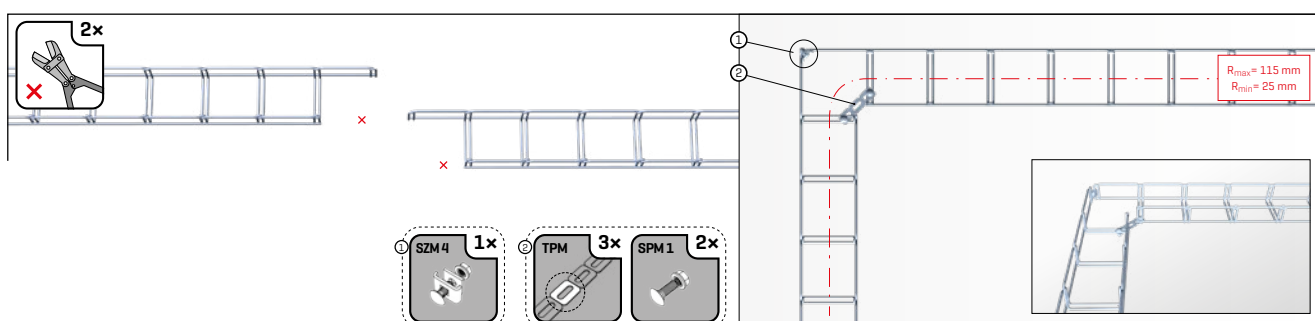
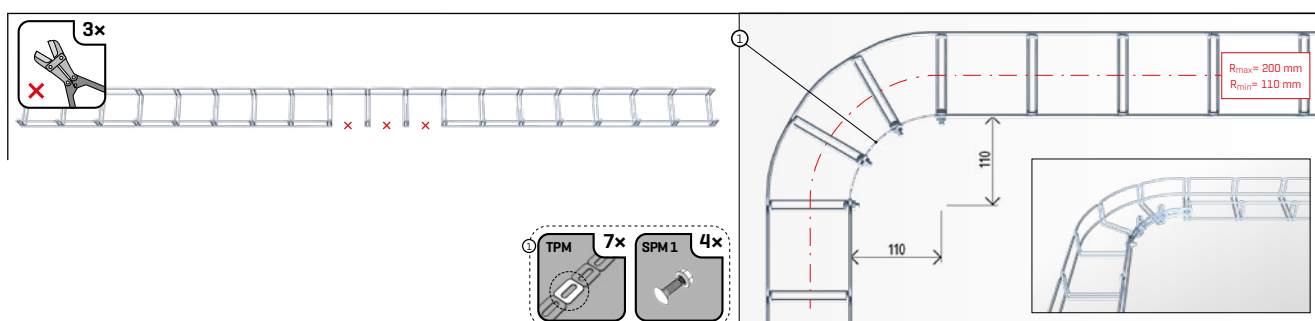
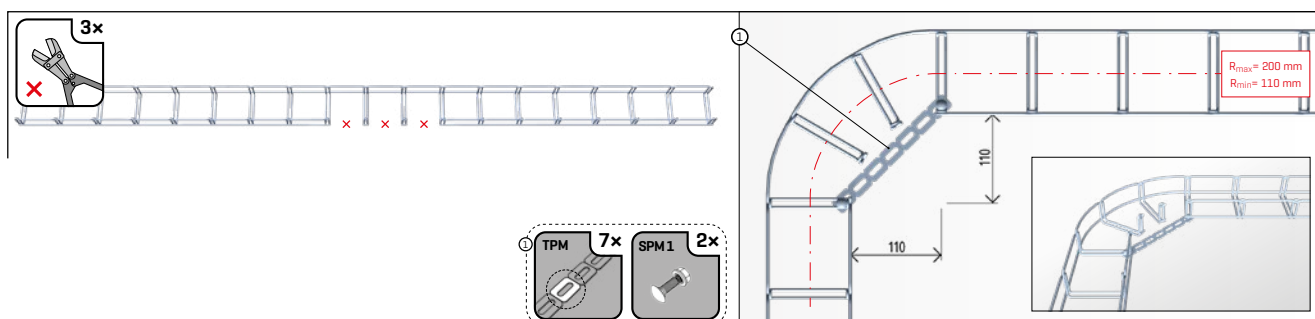
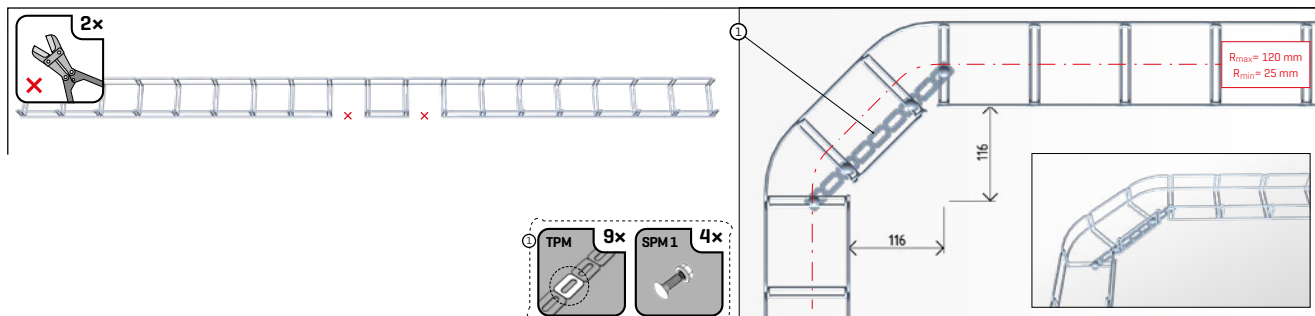
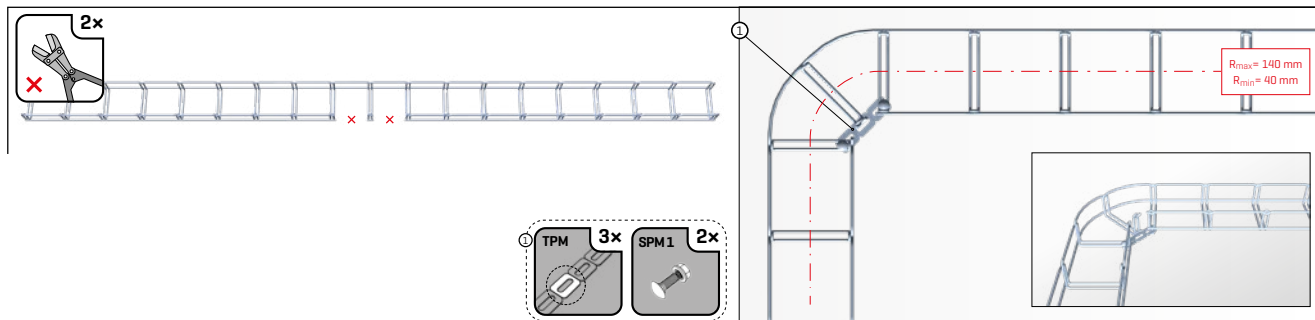

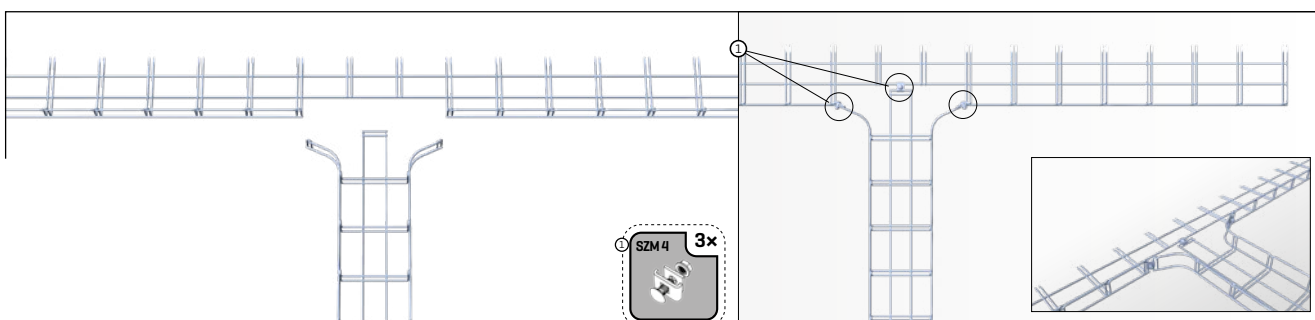
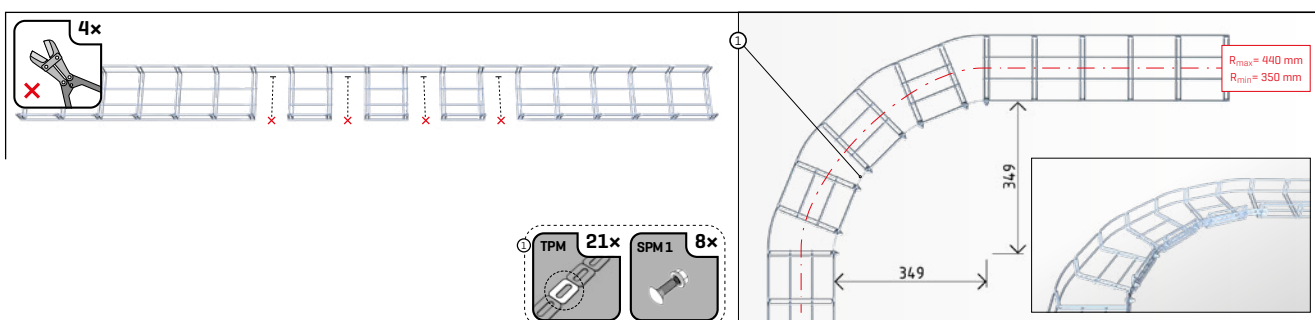
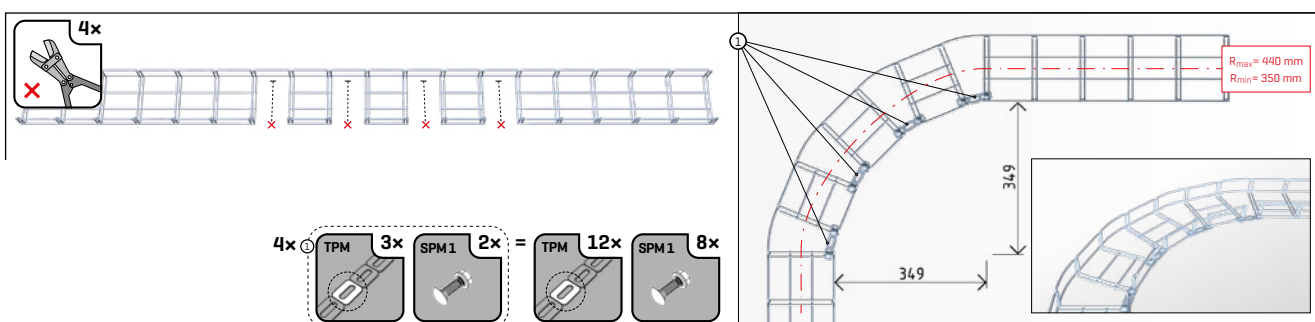
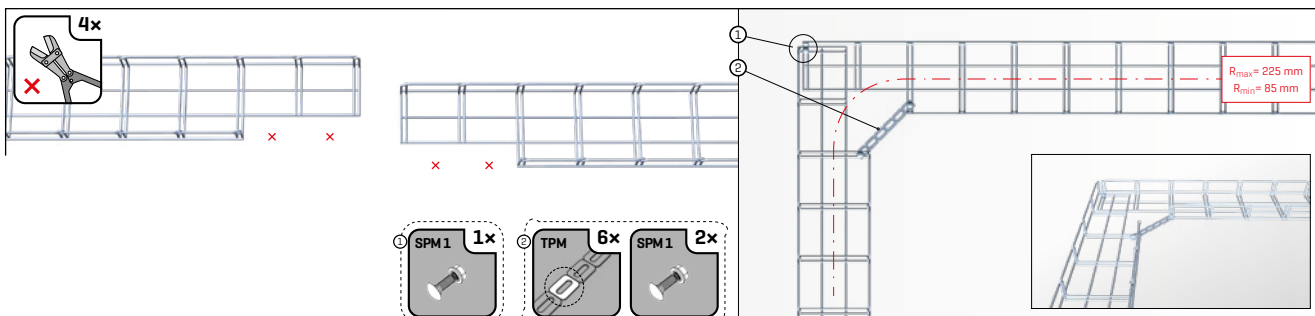
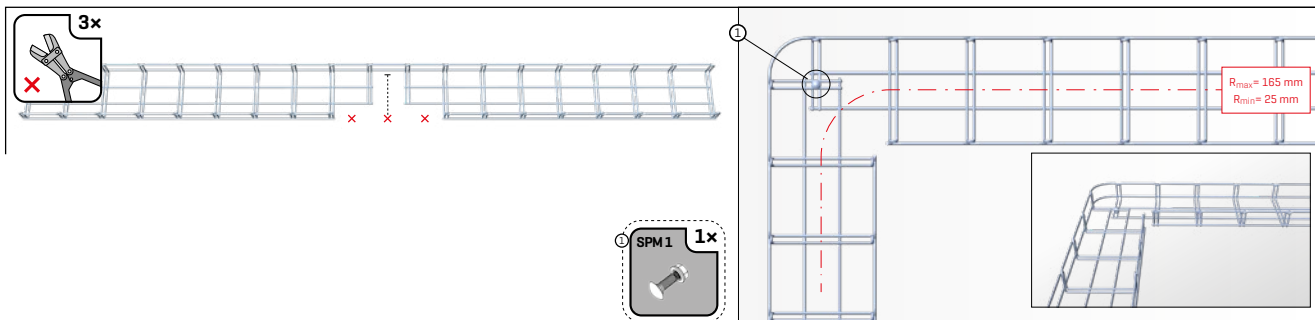

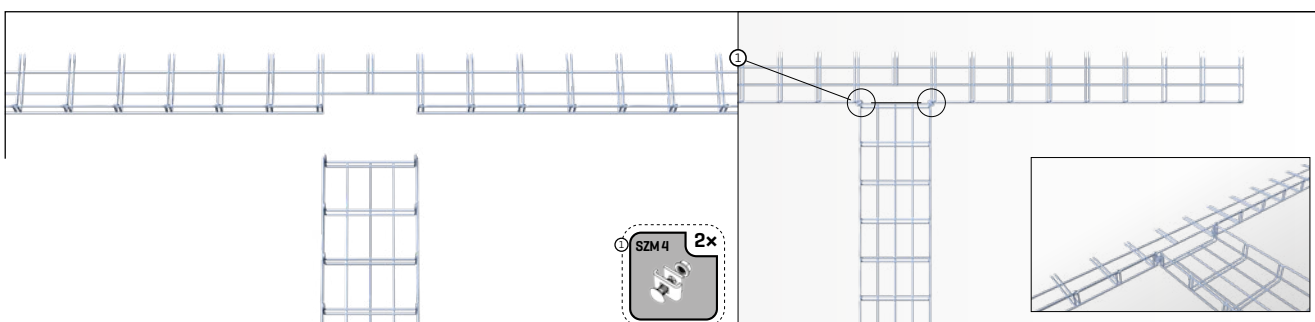
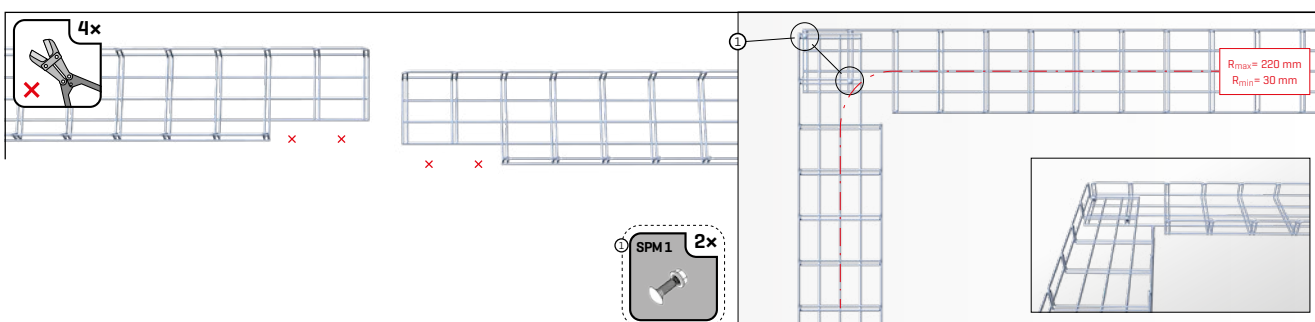
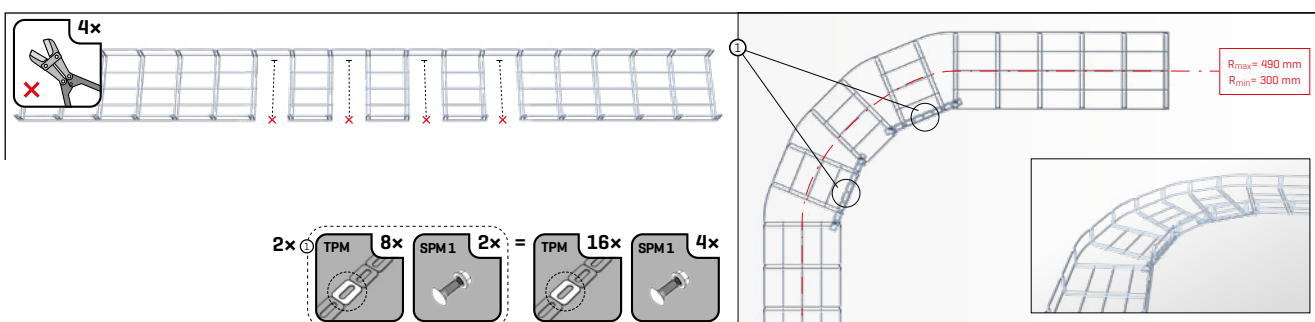
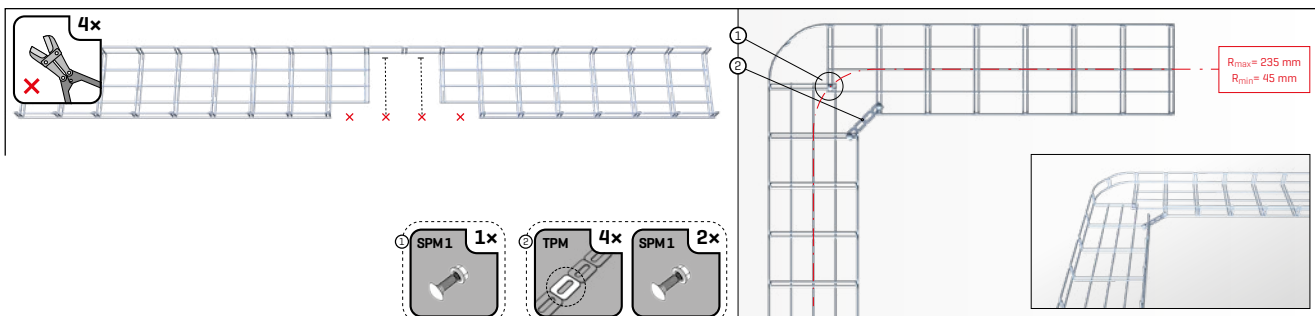
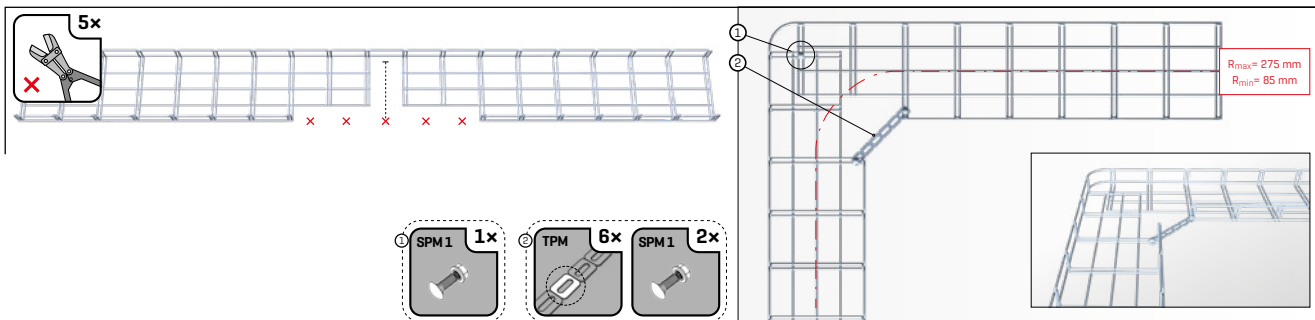

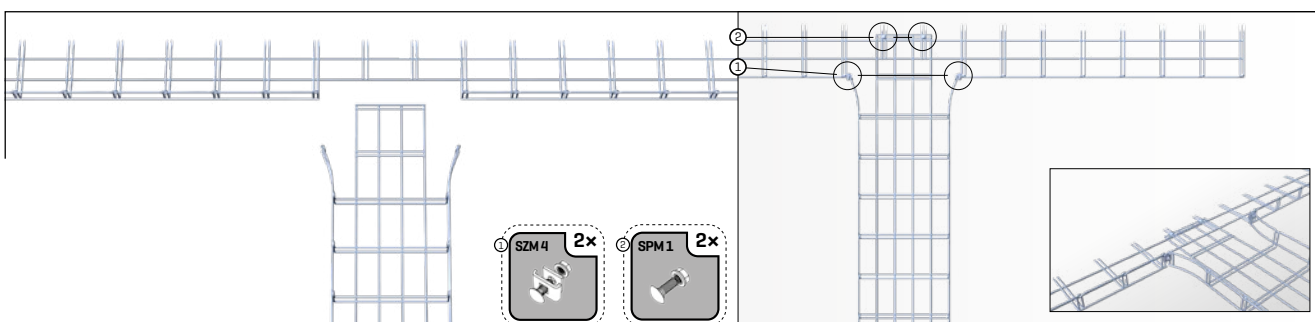
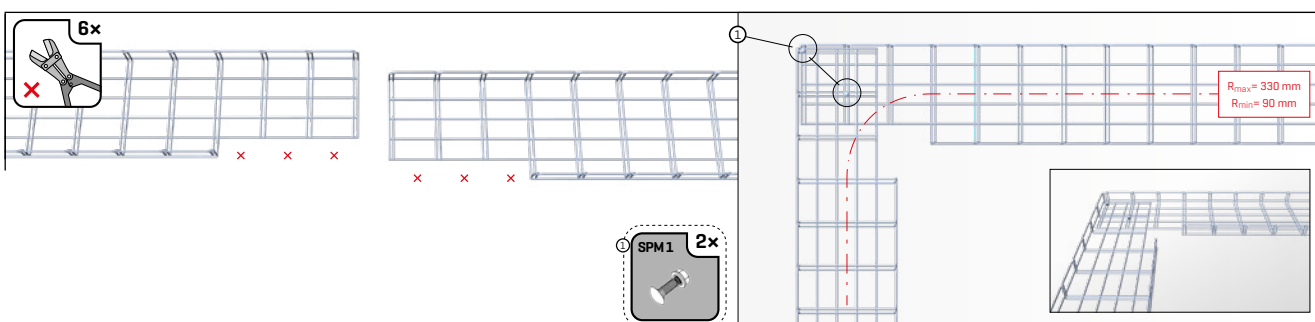
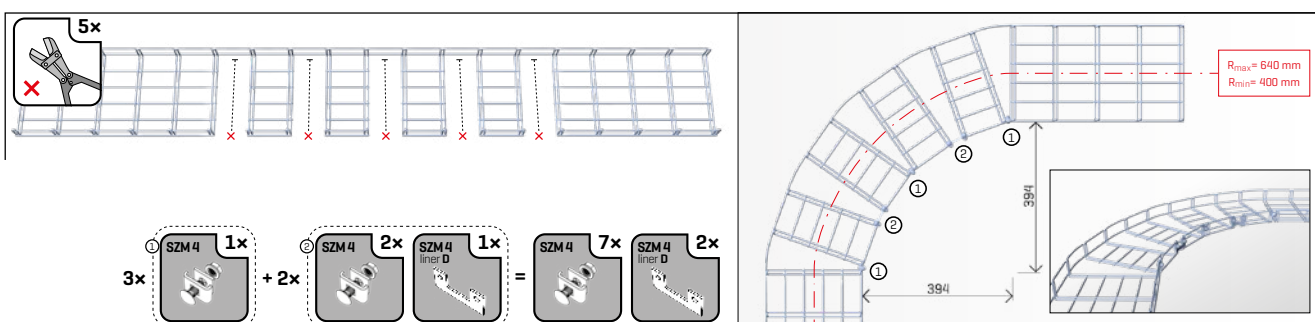
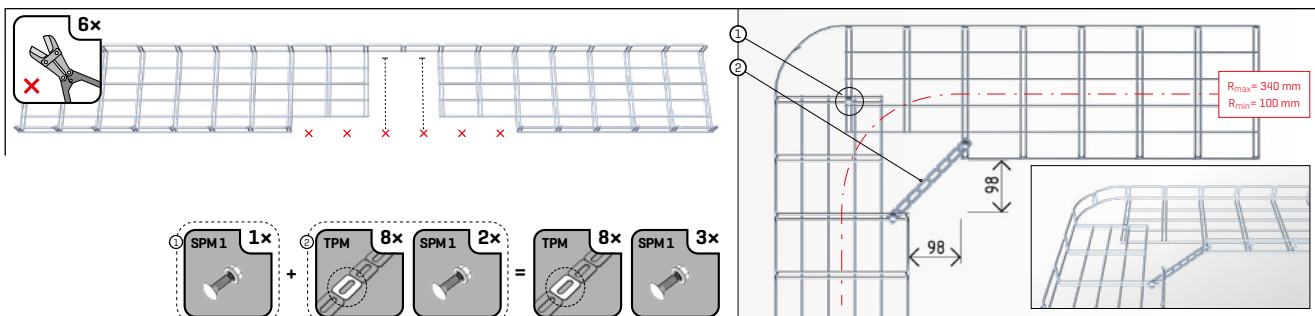
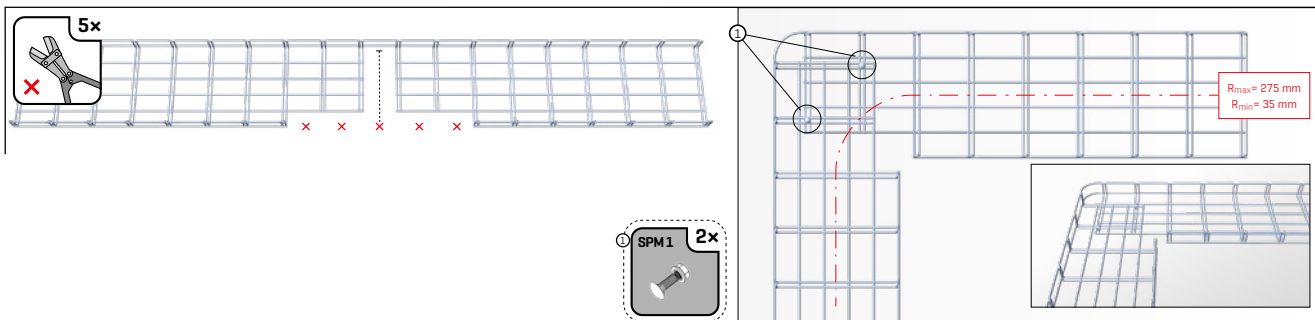

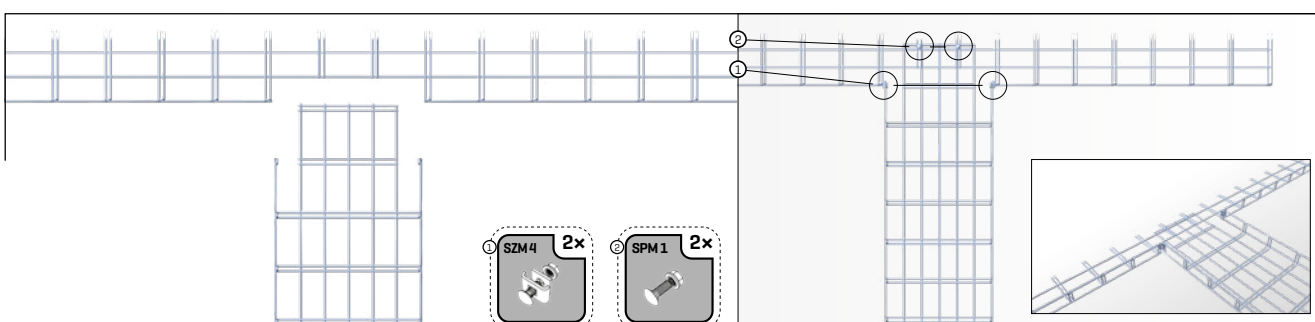
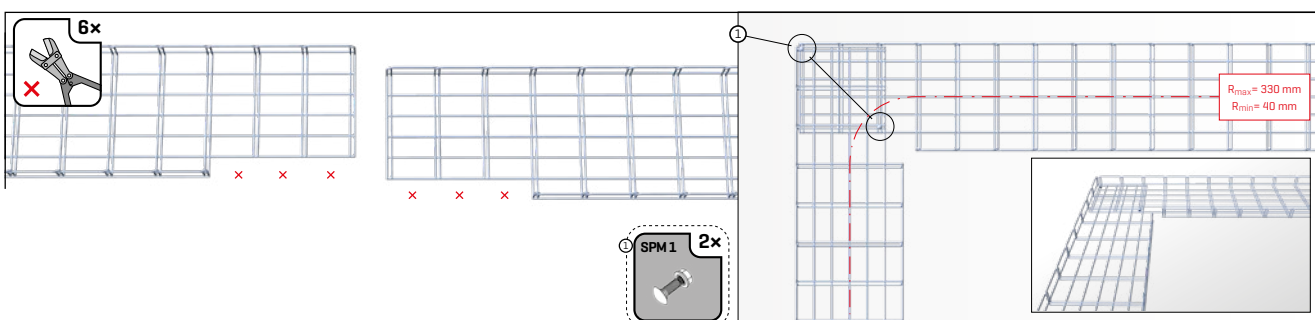
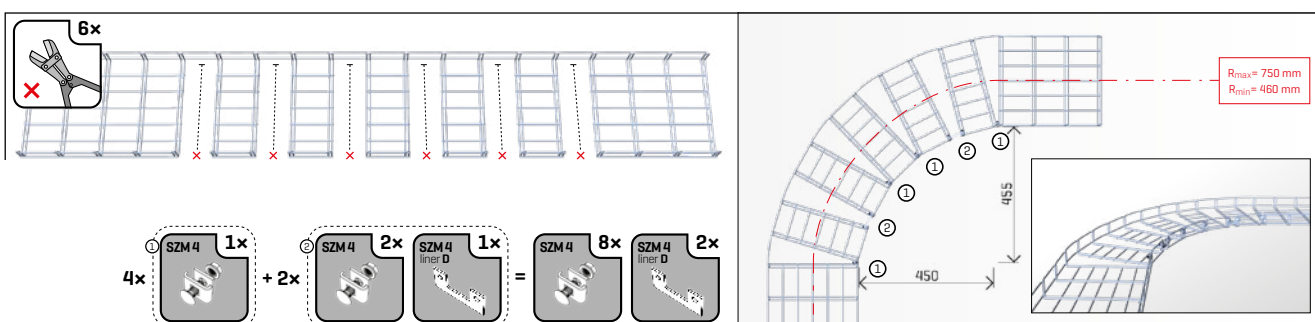
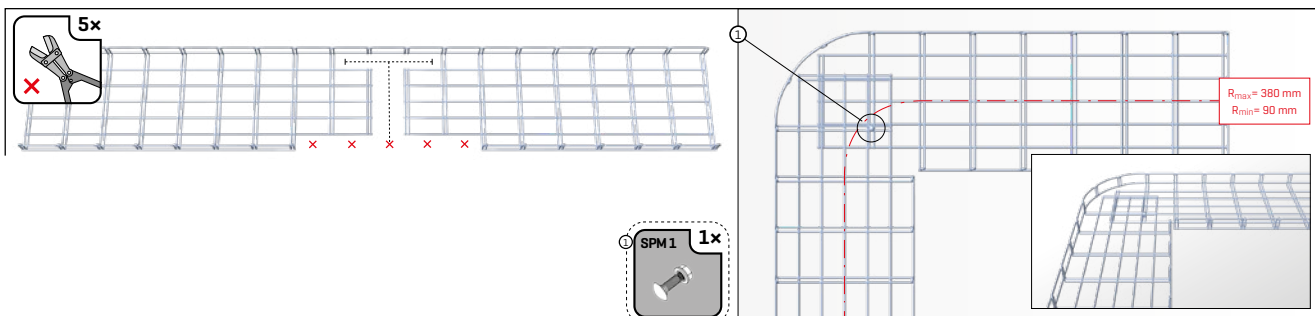
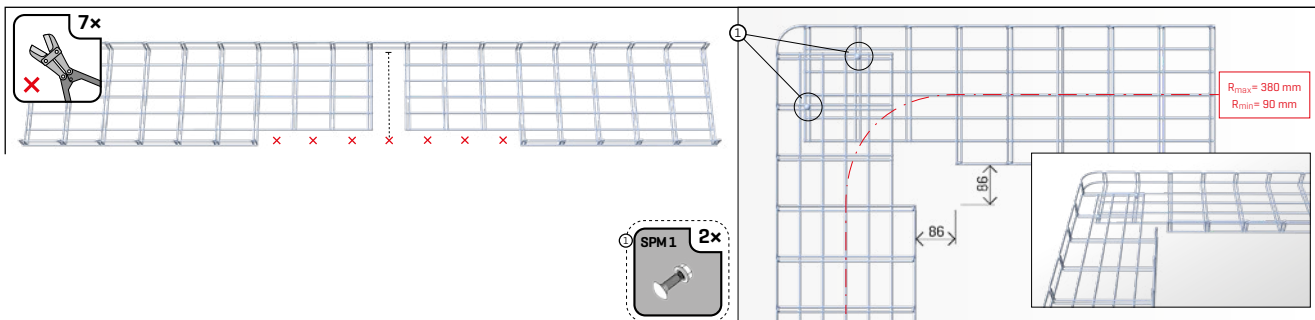

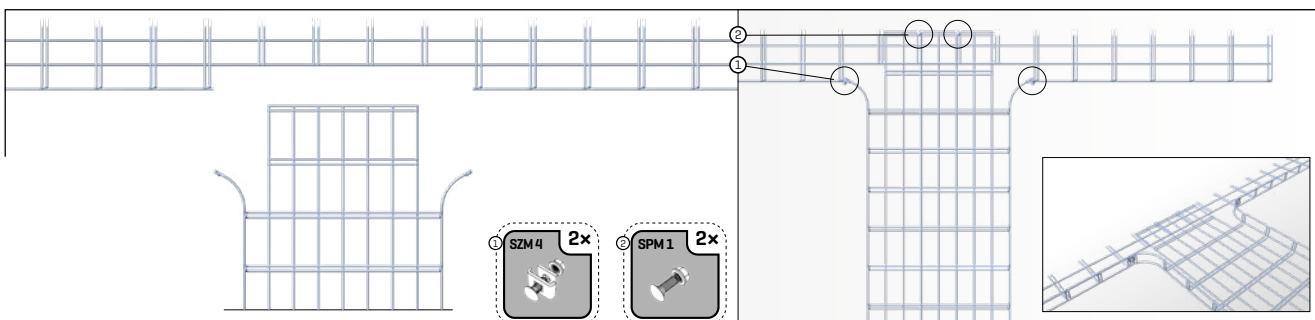
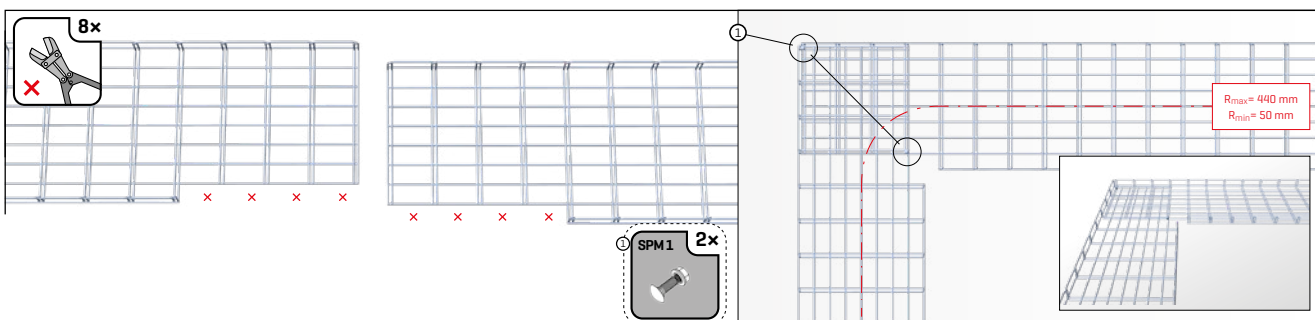
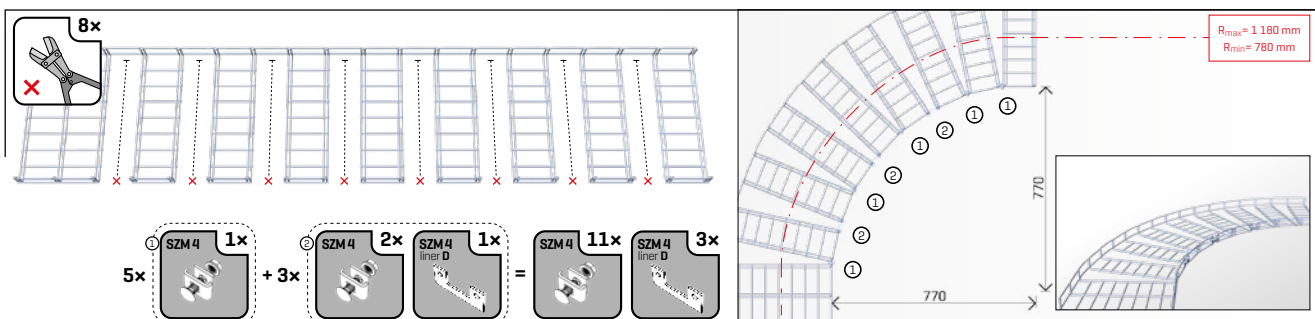
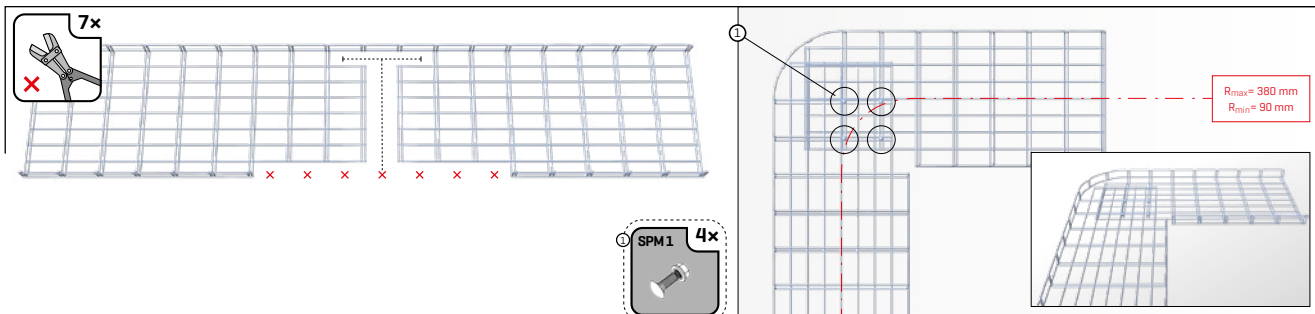
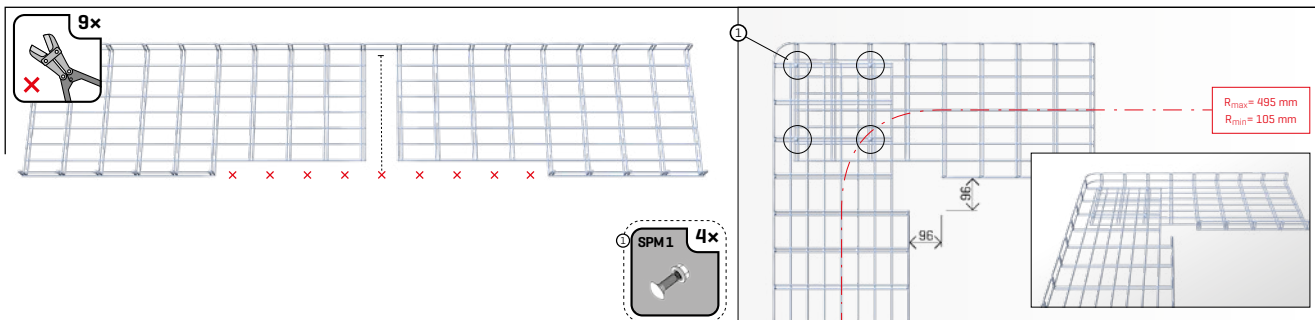

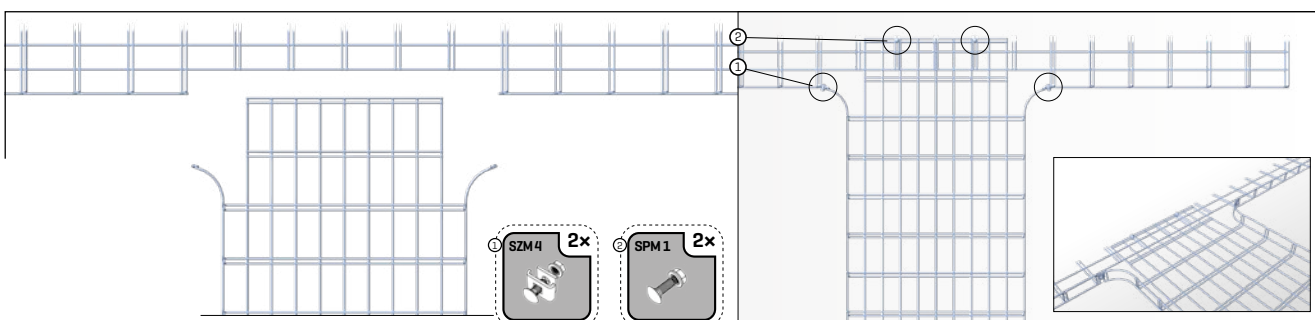
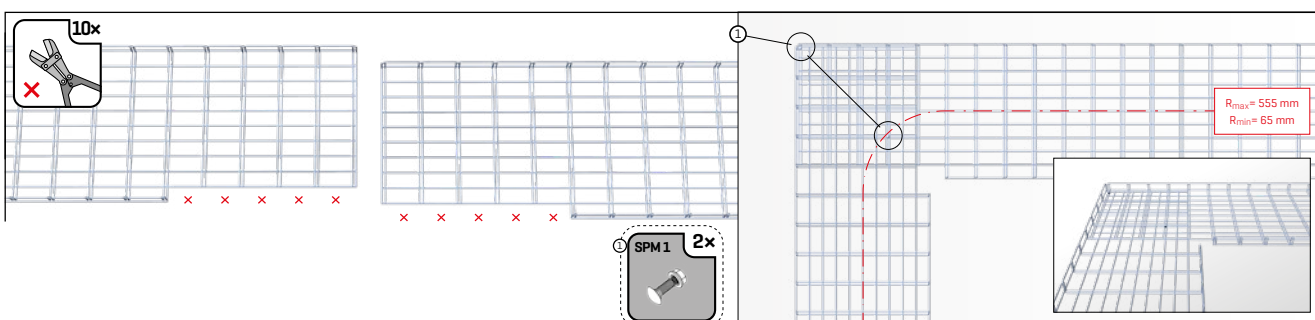
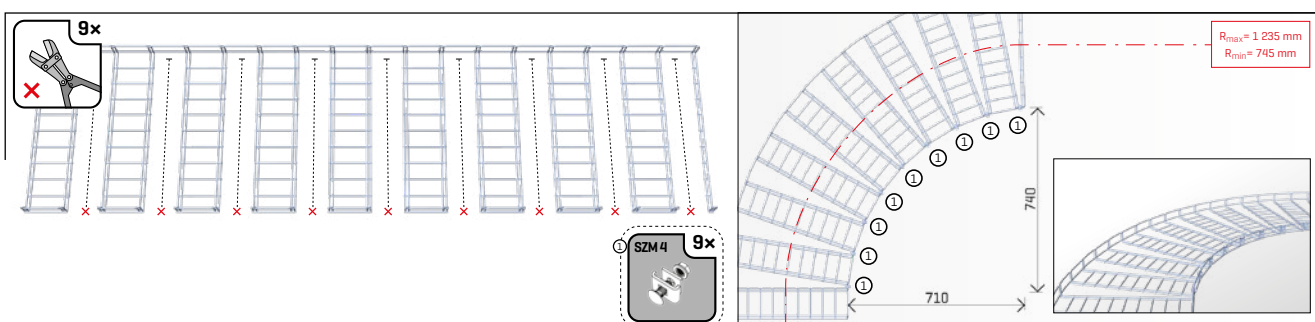
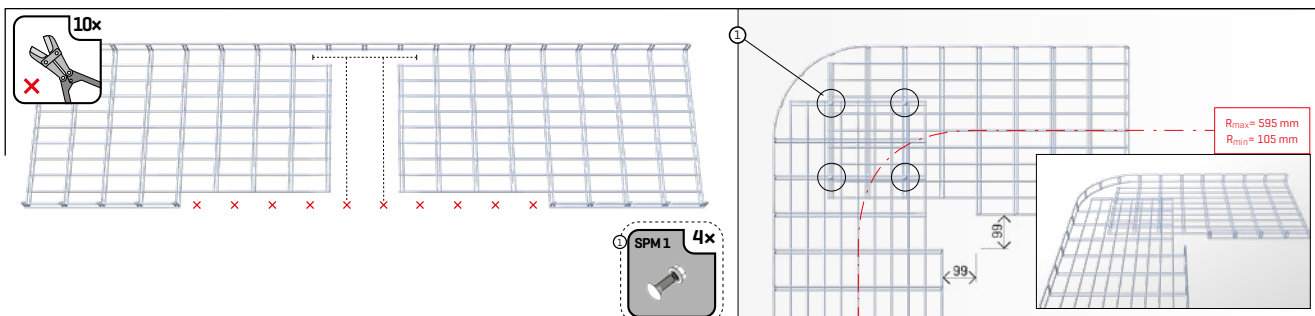
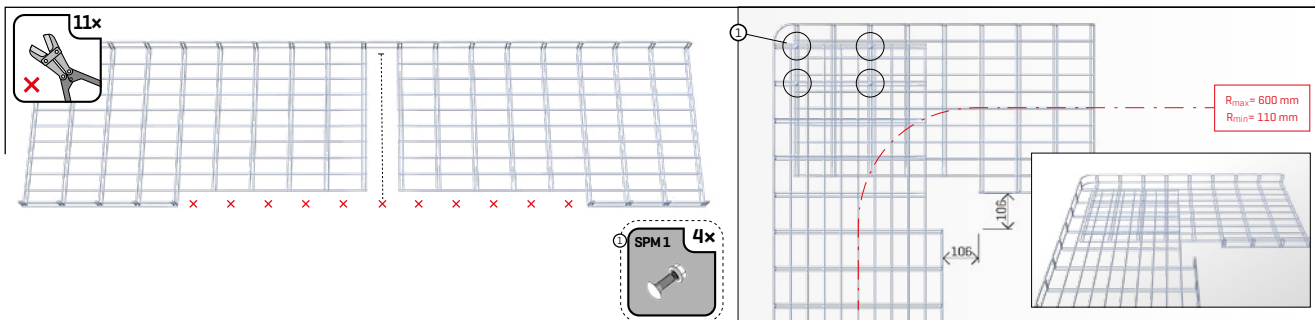

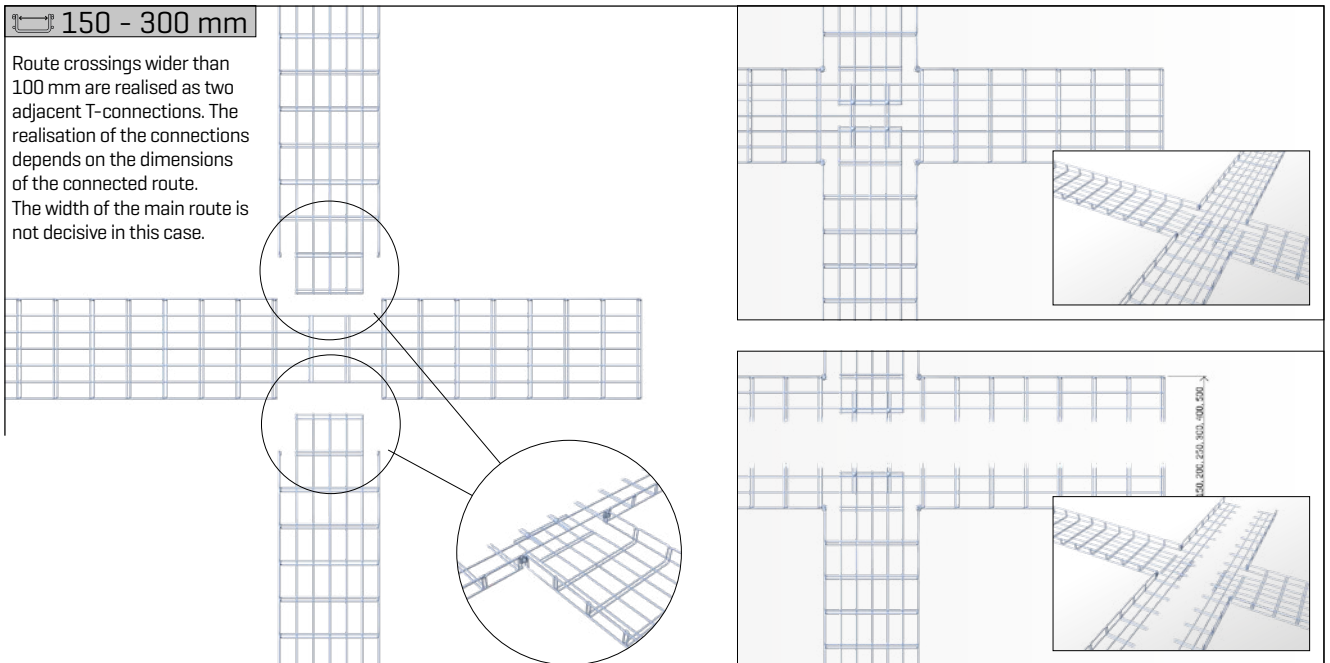
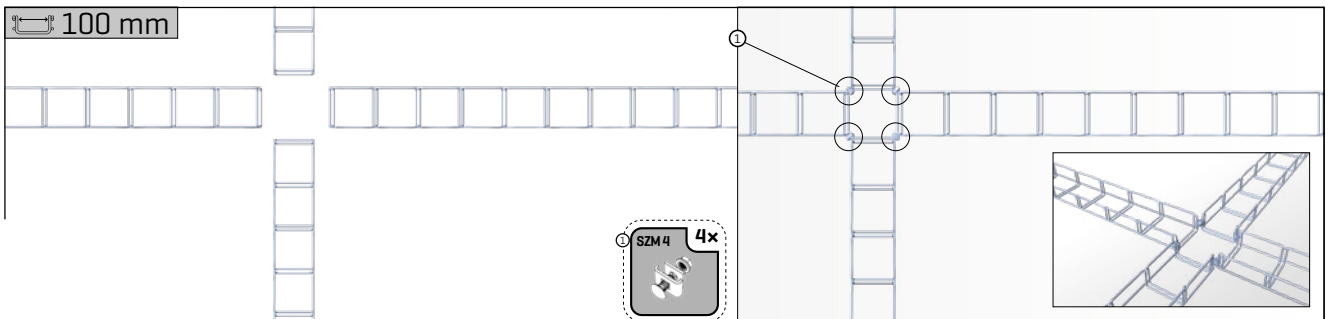
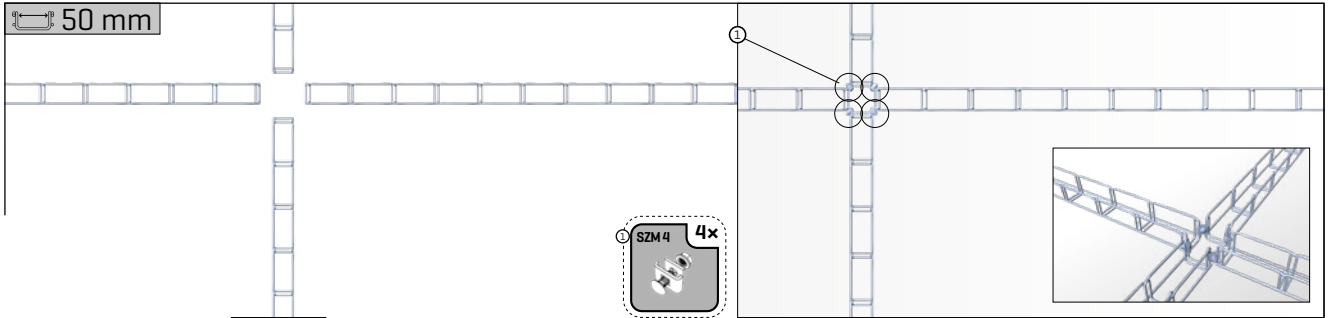
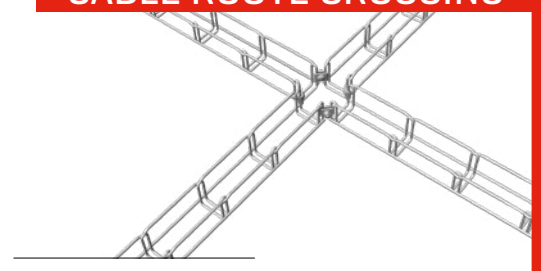



50, 100 mm

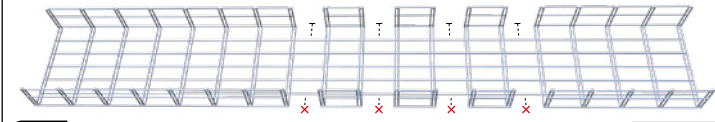

Spatial bends in the routes involving a transition from horizontal to vertical assembly are created according to the required radius of the route bend. It is possible to achieve larger bend radii with a greater number of snips. The bend radii and the bending diagram also apply to a side wall height of 50 mm.

	R = 65 mm
	R = 270 mm
	R = 410 mm
	R = 550 mm

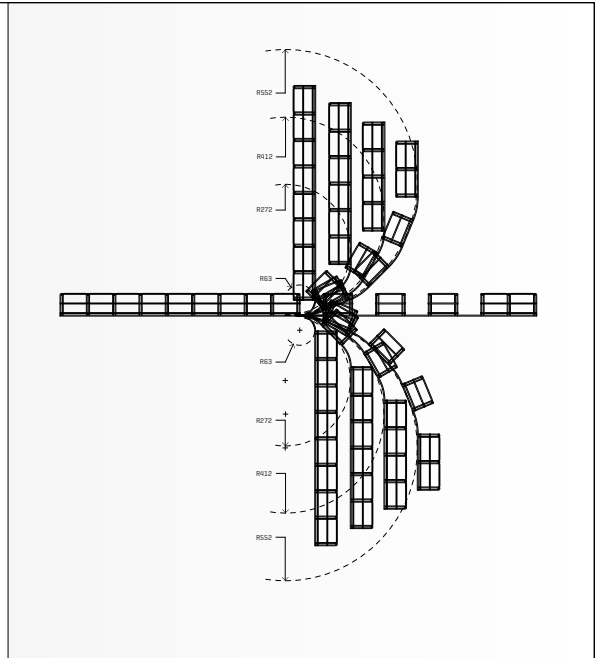

50 mm

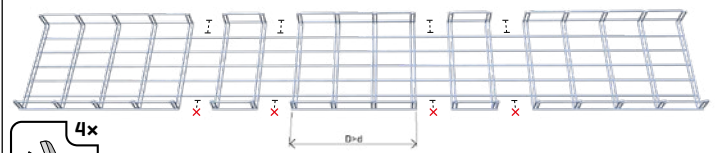

The spatial passing depends on the dimensions of the main route and the height of the side wall on the bent route.

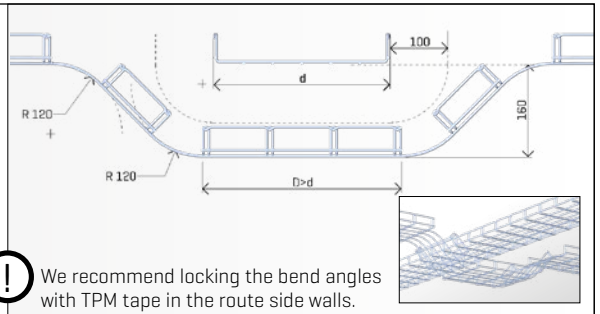

100 mm

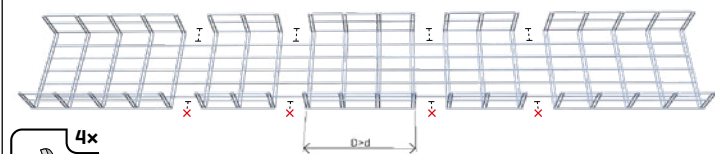

Spatial passing depends on the dimensions of the main route and the height of the side wall on the bent route.

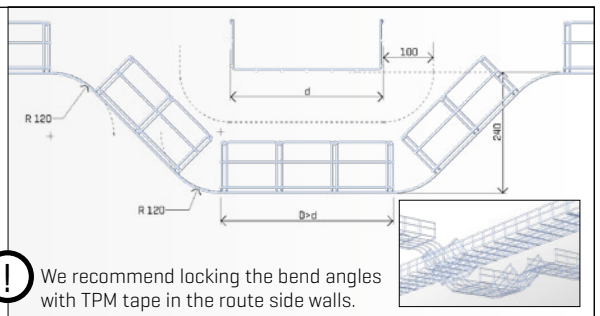

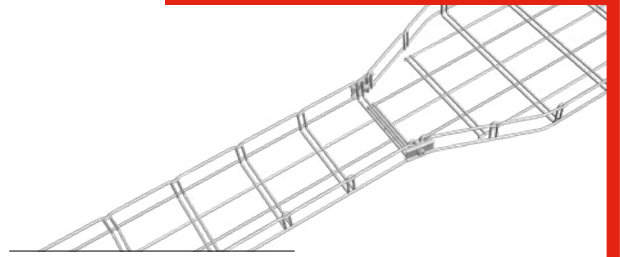

a lateral connection

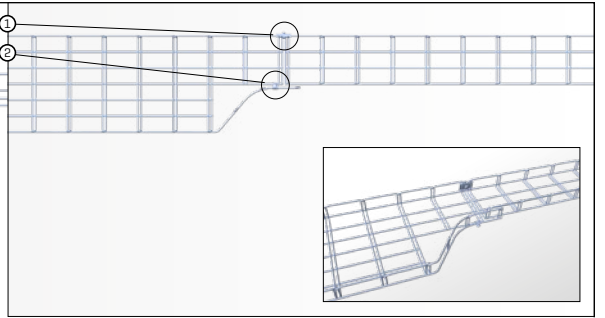
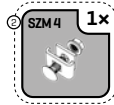
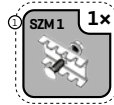
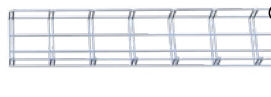
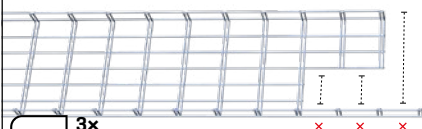

a central connection

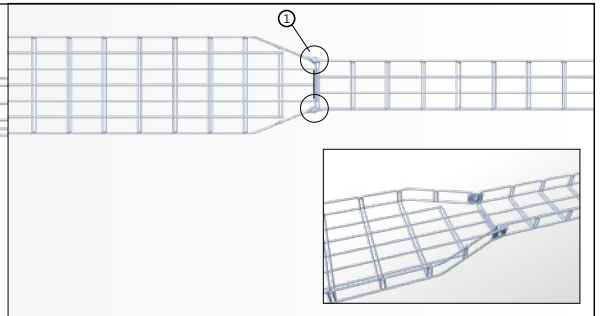
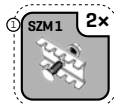
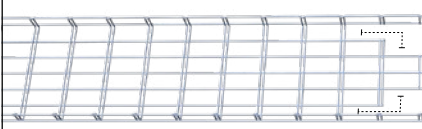

combined connections

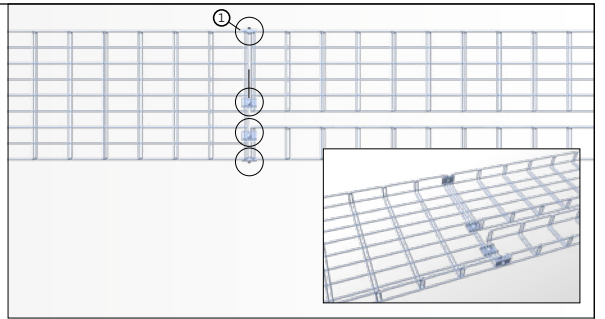
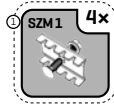
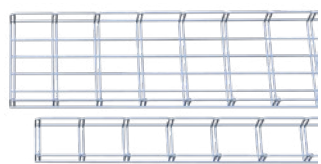
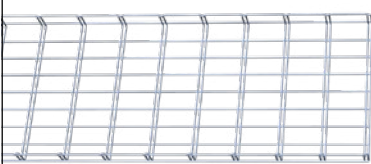

ARKYS®

ARKYS s.r.o.
Tuřanka 115a, Brno 627 00
Czech Republic
e-mail: arkys@arkys.cz
www.arkys.eu

CATALOGUE M2

10/2020 | Possible amendments of the document reserved. Arkys Ltd.

 **Ultima**
 www.ultima.hu

Ultima Kft.
Központi raktár: 1172 Budapest, Rétifarkas utca 6.
Telefon: +36 1 432 8820
www.ultima.hu

