

KAISER installation catalogue

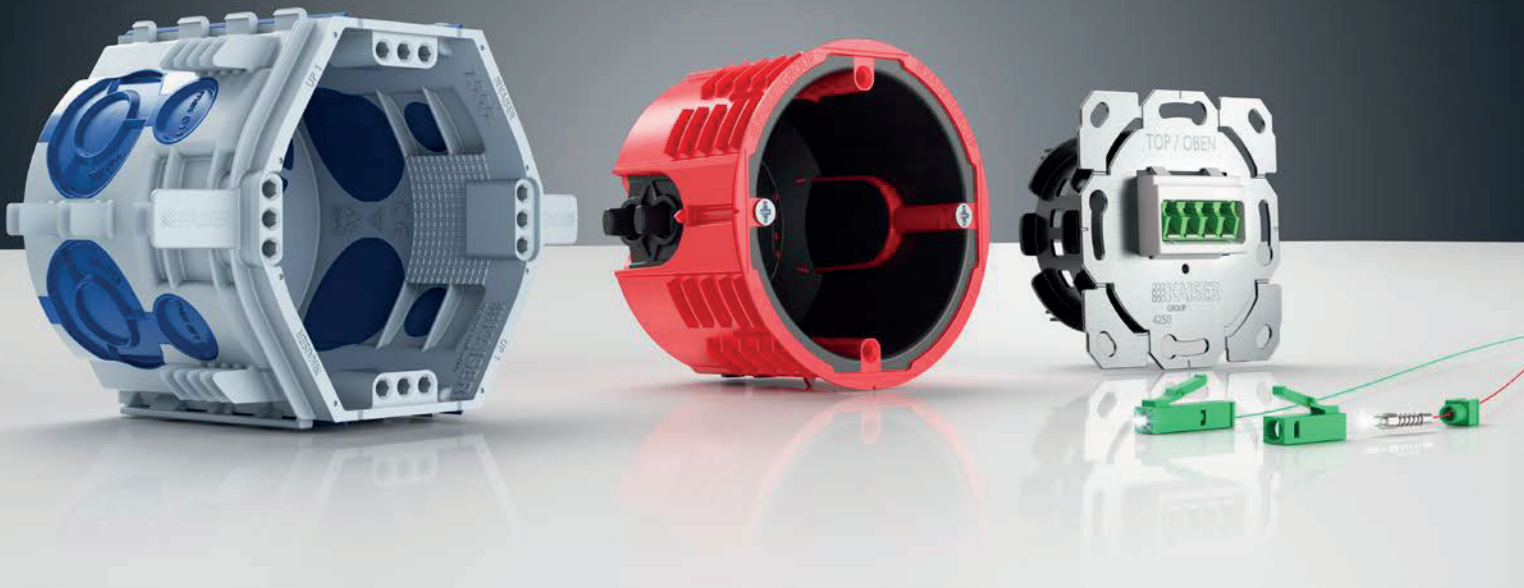

Boxes, housings and systems

2024 / 2025



The basis for professional installation





Shaping the future.

Constantly **rethinking** the present is the best way to actively shape the future. To scrutinise the tried and tested to see if there is still room for improvement. This applies to our products just as much as it does to our actions.

We believe that sustainable thinking and actions are also reflected in well thought-out and durable installation products and tools. These not only save you time when implementing your projects, but also directly reduce the use of energy and raw materials. Potential for improvement is continuously identified and utilised.

With our **new generation of UP¹ flush-mounting boxes**, we are providing more convenience and improved working ergonomics in our traditional business field of “electrical installation”. We have taken the professional and efficient installation of flush-mounting boxes to a new level.

Our product developments for **clean room, damp room** and **timber construction** applications also offer you certified solutions for applications that go beyond the ordinary. Our new products also offer a wide range of applications for **fire protection** requirements under building regulations. Feel free to take a look at our new generation of **HWD 68+ fire-protection boxes**. In the same way, our **new tool programme** with cutters for professionals stands for robustness, easy handling and precise work results.

For **120 years**, KAISER has stood for **“The basis for a good installation”**. Our products have set many decisive trends with innovative, safe and, in particular, solutions suitable for the trade. And we will not stop scrutinising the present in order to shape the future – we promise!

*Best regards,
Burkard und Ulrich Kaiser*

Flush-mounting / masonry

Complete system for all flush-mounting/masonry applications.
Air-tight, fire protection, sound insulation, internal and external insulation.



FLUSH-MOUNTING

Cavity wall

For all cavity wall types. Standard, air-tight and halogen-free.
Solutions for fire protection, sound insulation and radiation-protection walls.



CAVITY WALL

Concrete construction (on-site mixed concrete / precast concrete)

Boxes, housings, cable and conduit systems for on-site concrete and automated / manual factory production and for modular room modules like bathrooms or garages.
Universal installation housings and international products for walls and ceilings.



CONCRETE

Installation housings

For luminaires, loudspeakers, displays and much more. For walls and ceilings in on-site mixed concrete or precast concrete. As well as for fire protection requirements, insulated hollow ceilings and thermal insulation systems.



HOUSINGS

Fire protection

Box, housing and sealing systems for fire-protection walls and ceilings.



FIRE PROTECTION

Pluggable installation / surface mounting

Modular distribution boxes for cable support systems.
Waterproof cable junction casing for outdoor applications.



PLUGGABLE

Connectivity

Solutions for professional fibre-optic and broadband expansion.
Fibre-optic laying and installation in street distribution (network level 3) and building and unit distribution (network level 4).



CONNECTIVITY

Cable glands

The professional Syntec® programme. Fittings in all sizes in plastic and brass.



CABLE GLANDS

Tools

High-quality system tools for professional electrical installation.



TOOLS

Service

Wanted. Found. From communication to the item number.

SERVICE



Assume responsibility.

KAISER has been on the market as a family-run company with integrity, fairness and reliability for 120 years. We are recognised as a pioneer and innovation leader that has always defined new standards for the entire industry. Our understanding of corporate and social responsibility is part of our DNA. It has been serving us as a guide for three generations, determining our strategic decisions and our actions.

We believe that sustainability is an important pillar of entrepreneurship. In addition to the very tangible factors such as energy, raw materials and resources, we understand sustainable action to be, in

particular, our mission to be aware of our social responsibility. We demonstrate our attitude towards our partners in the market and are happy to document this by signing the ZVEI Code of Conduct. With the four locations of the KAISER GROUP in Germany, Belgium, the Netherlands and Switzerland, we are well networked in Europe and can therefore identify real trends, focus our energy on relevant topics and quickly feed adjustments back into the markets.

We would like to thank you for your trust in us and invite you to shape the future together with us.

Join us on this exciting journey.

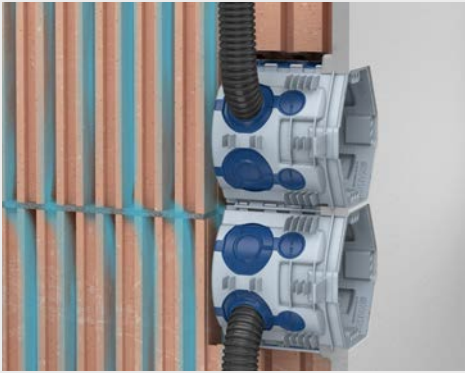

Our best flush-mounting box. UP¹.

- 25 % more installation volume
- Plaster-free quick-fixing with clamping ribs
- Stable and side-neutral combination



For the Features



1555-26



1055-26



1068-26



1656-26



Professional clean room installation. Clean room one-gang junction box.

- For professional installation in clean room walls and functioning containments
- Certified according to VDI 2083 sheet 19 (tightness class 7, extended class 11)
- Air-tight design with sealing membranes and peripheral sealing lip



9264-32



With universal screw-on surface. Installation housing O-range ECON® Universal 120.

- For mounting accessories and installation accessories
- For individual round and cornered installation openings
- Toolless cable or conduit entries



9273-50

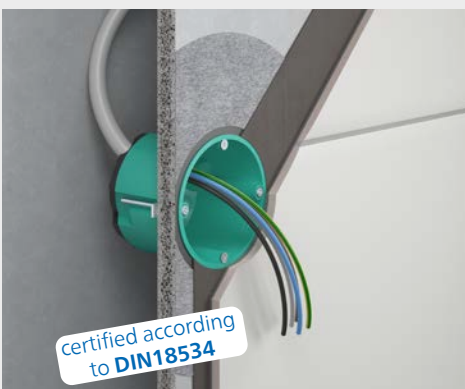

Optimum sealing of the electrical installations: Waterproof one-gang junction box.

- For installation in sealed interior rooms, such as commercial kitchens, bathroom modules or damp rooms in hospitals
- Tested and certified water tightness
- Six air-tight and watertight cable entries

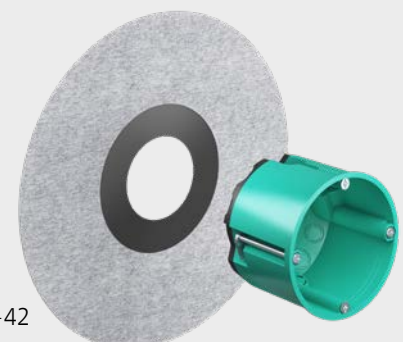

9264-42

pg. 118



9274-22

To the product film



Efficient installation in timber construction. **One-gang junction box for solid wood.**

- Clamping rib fastening for installation
- Four screw domes
- Eight air-tight, toolless cable entries



pg. 120



9261-20

9261-25

For prefabricated house and module construction. **90° wall and ceiling transitions.**

- For air-tight connecting of electrical installation conduits at transition points
- Air-tight component closure for front and rear installation in the boarding of wall elements or modules
- Flexible cable entry from both directions thanks to 90° elbow without abutting edges



pg. 286



9464-05

To the product film



Safe installation in timber construction. **Solid wood fire protection box PROTECT®.**

- Maintains the F30-B– F120-B fire resistance
- Toolless installation thanks to rib fixing
- Innovative cable entry enables tolerance compensation of the cable route



pg. 284



9464-03

9463-03

To the product film



Safe installation in drywall construction. **One-gang and one-gang junction fire protection boxes HWD68+.**

- For F30–F90 or EI30–EI90, as well as F30-B – F90-B fire-protection walls
- Sound insulation function of the wall
- Toolless cable and conduit entry



pg. 190
pg. 228



9914.10

For universal installation entries. **Central transition casing**

- For leaving out several cables
- Conduit entries for Ø 20, 25, 32, 40, 50 and 63 mm
- Positioning of the conduit entries above the first reinforcement layer or the top of the filigree ceiling



Subscriber connection (FO-SC) E3S Connect®, surface mounting / flush-mounting, connection at HTP / FO-BD



- With pre-assembled E3S fibre-optic cable in different lengths
- Cable retractable, insertable and blowable
- Pre-assembled cable with 2 or 4 fibres in a handy unwinding box



To the product film

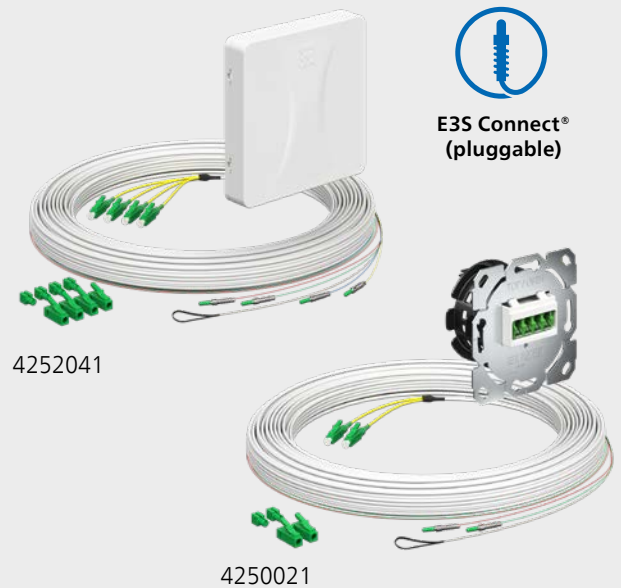

E3S Connect® (pluggable)

Distribution box for data networks. AK2 Data & AK2 DALI.

AK2 Data:

- Front part equipped with break-out openings for adapters to accommodate Keystone modules.

AK2 Dali:

- Prefabricated with 5-pin snap-in connectors for DALI applications
- Connectors are self-locking, can be released with tools
- Prefabricated with halogen-free connection wires 2.5 mm².

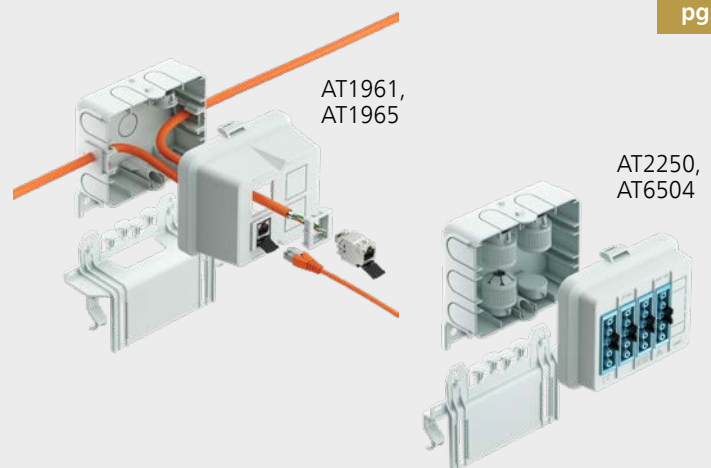

AT1961, AT1965

AT2250, AT6504

Drilling with a triangle. Trilo – The new cutter generation.

- Improved operating life time thanks trilo geometry
- Fast working due to easy / reliable ejection of the drill core
- Dimensionally accurate work for cavity wall installation



1081-10

To the product film



1082-30





Energy efficiency & ETICS.

An essential component of the energy transition is energy efficiency. With professional insulation that complies with current standards and regulations,

Flush-mounting Page 14, 54, 58

Cavity wall Page 97, 122

Luminaire and loudspeaker housings Page 266



Fire protection.

Structural fire protection measures serve the purpose of preventing the spread of flames and smoke in the event of a fire, so that escape and rescue routes remain usable.

Fire protection Page 274



Sound insulation.

Sound insulation walls make a significant contribution to well-being in buildings, as they allow for quiet, confidentiality and security.

Flush-mounting Page 39

Cavity wall Page 130



Radiation protection.

Structural radiation protection measures are used in hospitals, doctors' surgeries and any facility where X-ray and gamma irradiation equipment is used

Cavity wall Page 138



Construction / Timber construction.

For efficient, safe electrical installation – regardless of whether these involve new construction or conversion, extension, renovation or refurbishment.

Flush-mounting Page 69 / **Cavity wall** Page 118

Fire protection Page 286

Luminaire and loudspeaker housings Page 266



Pluggable installation.

Simple, fast and secure. Pre-assembled components and systems are in demand as a solution for planning and installation, especially for efficient, on-time construction.

Pluggable Page 306

Connectivity.

Fibre-optic technology is today's state-of-the-art cabling technology for telephony, Internet and television not only in the wide-area network and street distribution but also in the building distribution right down to the residential unit.

Connectivity Page 318, 340



Cable glands.

AGRO cable glands made of plastic, brass or stainless steel stand for highest quality and practicality. The innovative complete range offers everything for professional cable entries in any trade or for industrial purposes.

Cable glands Page 358



Concrete construction – on-site mixed concrete.

The modular KAISER system is universally applicable for all concreting methods and formwork types.

Concrete construction Page 156



Concrete construction – precast concrete.

The KAISER product range for precast concrete comprises the B² system with one-gang junction boxes, special slab ceiling boxes and housings as well as the Flat 45 system for serially pre-fabricated room modules.

Concrete construction Page 208

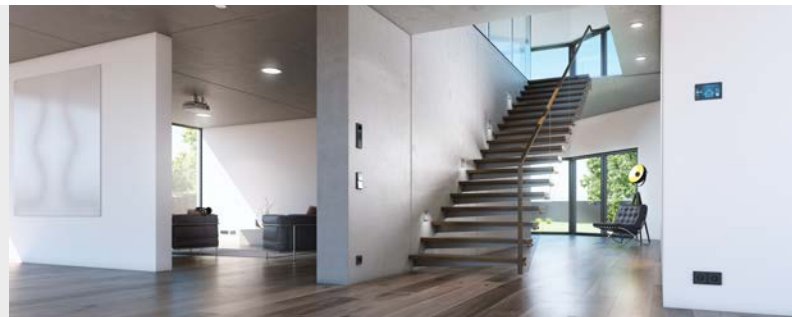

Luminaire and loudspeaker housings.

KAISER offers a wide range of installation housings for luminaires and loudspeakers for installation in concrete walls / ceilings, cavity walls / ceilings and ETICS.

Luminaire and loudspeaker housings Page 242



Shipbuilding.

KAISER offers solutions for use in passenger ships, such as cruise liners, passenger and car ferries or yachts, but also for cargo ships, such as LNG tankers and container ships, as well as for a wide variety of special ships up to naval frigates or even aircraft carriers.

Cavity wall Page 91
Fire protection Page 290



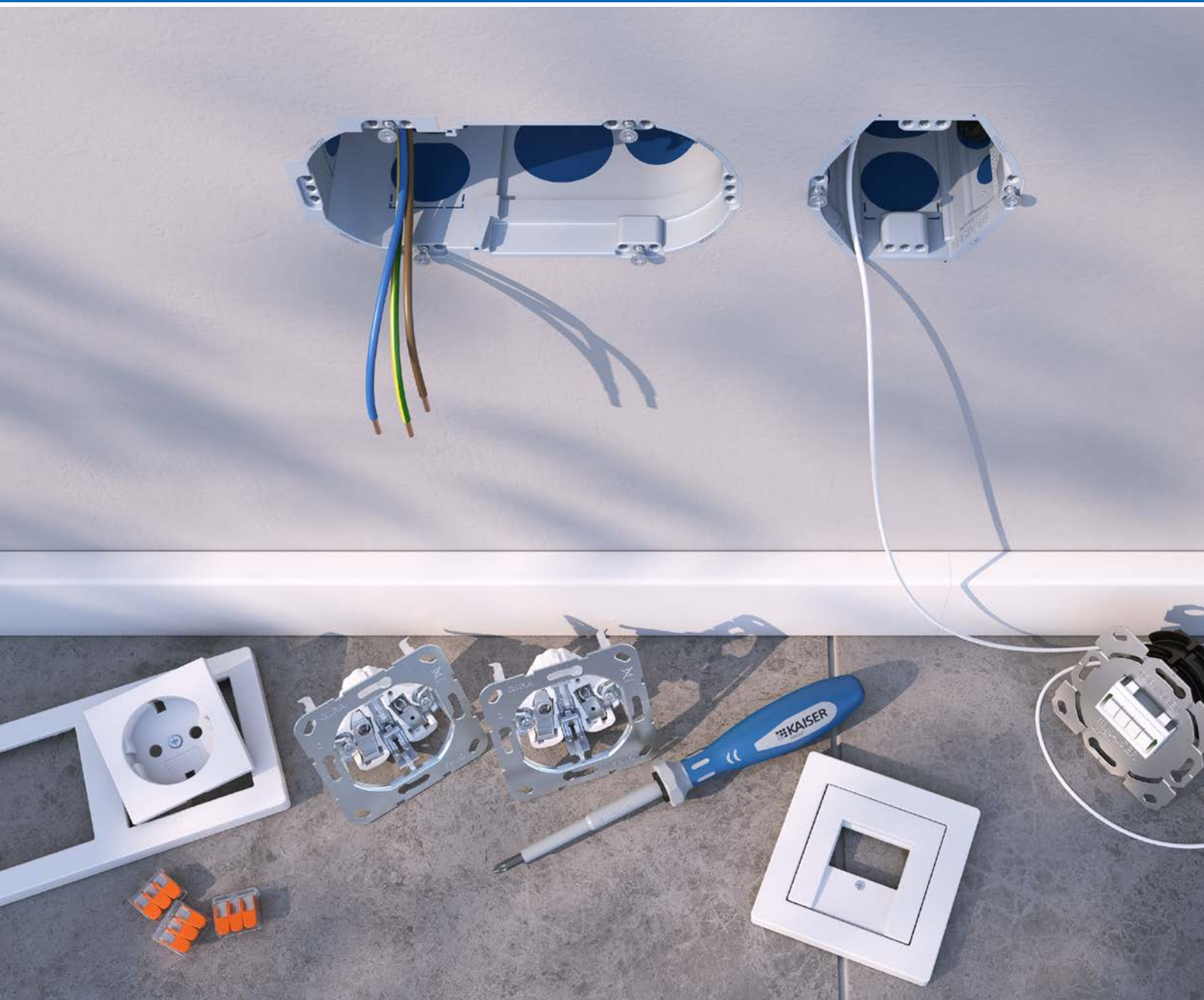

Well informed. KAISER Service.

When you decide to use KAISER products, you always receive comprehensive service as well. This allows both you and your customers to take advantage of all the benefits we offer.

Videos on products and applications Help-ful tips & tricks for your everyday work. Here we clearly show all product and processing advantages, installation instructions, certificates and declarations of performance as well as conformity that make the product perfect.

Intelligent product filters in the online catalogue help you with your product

selection. Our BIM data, tender texts and CAD data are important building blocks for your digital planning.

- Online product catalogue
- Download of digital media
- Seminars, trade fairs and events
- Technical sales and service consultation

- Article master data and price information
- Tender texts
- BIM data
- CAD data



BIM



Videos

Our films/videos - product features at a glance



For any products where you find this icon, we provide informative films about the installation and function of many products and system solutions on our website as well as on our YouTube-channel.



Article data

Article master data in the formats: ETIM, Eldanorm, Datanorm and Excel as well as prices for our products can be found in the service area on our website. Using the ELBRIDGE interface, you conveniently transfer your product selection to the electrical wholesaler. .



Training courses

Qualified training courses on KAISER product and system solutions at our premises or at your location upon request. Please contact us.



Online / Service

Planning documents and product information

KAISER provides BIM and CAD data as well as tender texts and EPLAN data on leading platforms to optimally support our customers and partners in the planning and implementation of projects.

The most important websites at a glance:

- www.kaiser-elektro.de
- www.youtube.com/kaiserelektro
- kaiser.partcommunity.com
- www.ausschreiben.de
- www.eplandataportal.de/agro
- www.kaiser-elektro.org/elbridge



The QR codes ensure quick and convenient access with your smartphone.

Flush-mounting installation



Flush-mounting base installation

- Complete system for all flush-mounting / masonry applications
- UP-PLUS technology with combination spigot M20/M25 and up to 15% more installation space
- Plaster-free assembly with KLEMMFIX®
- Easy retrieval of boxes and casings through the use of signal covers
- International products for accessory installation according to national standards
- Halogen-free

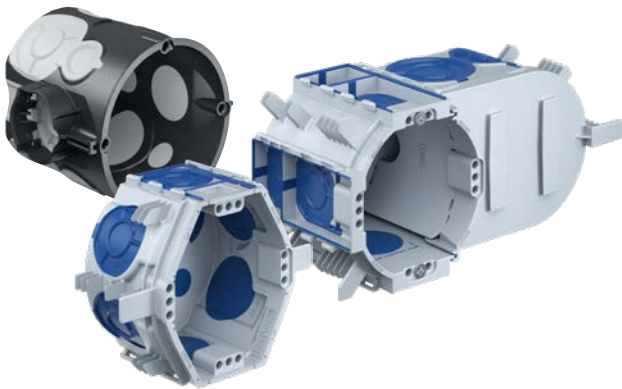

Air-tight flush-mounting installation

- Air-tight installation as per GEG
- ECON® technology: air-tight device, one-gang junction boxes for toolless cable and conduit entries
- Air-tight sleeves for the air-tight feed-through of cables and conduits



Flush-mounting special solutions

- Fire protection products
- Sound insulation products
- Universal installation housing with mineral fibreboard for all common unit sizes (e.g. displays, LED luminaires, etc.)
- Installation solutions for environmentally-friendly construction



Insulated walls and ceilings

- Installation solutions for insulated walls and ceilings (ETICS)
- Secure fastening
- Prevention of heat bridges

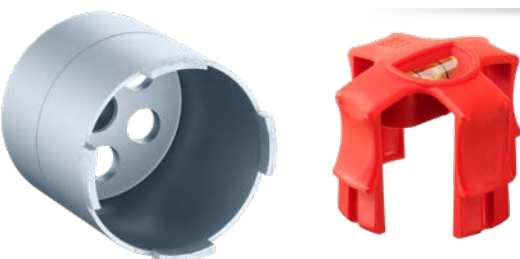

Tools

- Professional system tools for fast, safe installation
- Extensive system accessories

see chapter **TOOLS**
from page 376



UP¹ flush-mounting boxes

UP¹, the new flush-mounting range for electrical installation, takes flush-mounting installation to a new level and makes it easier than ever before. 25% more installation volume compared to conventional flush-mounting one-gang junction boxes enables convenient accommodation of cables, connection terminals and installation accessories. The quick-fixing by means of ribs in all stones ensures up to 50% time savings during installation without plaster. The side-neutral and stable combination quickly allows multiple combinations to be created at a 71 mm centre distance. Thanks to open through-wiring and breakaway bridge, the device connection can be made without spatial separation. Accessories that are already wired, especially sockets, can therefore be installed particularly quickly and easily. The entries close to the base and through-wiring close to the base maximise the usable wiring space and facilitate the installation of the installation accessory due to the low-lying wiring material. Thanks to expanding claw fields and 4 x 3-fold screw domes, fixing the accessory is easier and more flexible than ever before. The new plaster compensation frame enables continuous plaster compensation from 10 to 35 mm with only one accessory.

- 25% more volume compared to conventional flush-mounted one-gang junction boxes
- Quick mounting in all wall constructions (ribs on the box, no mounting of accessories, use of PU foam is possible)
- Stable and side-neutral combination
- Open / diverse through-wiring
- Fully insulated through-wiring close to the base for deep boxes
- Entries close to the bottom of the box
- Triple conduit feed M25 from one direction to one-gang and one-gang junction boxes
- ECON[®] multi-cable conduit entries
- 4 triple screw domes / expanding claw fields
- Entries in the bottom of the box
- Stepless plaster compensation (accessories)



Application examples

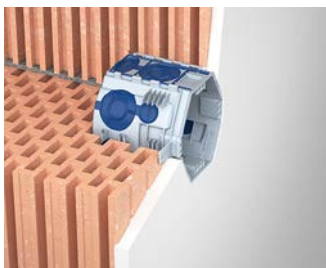

Vertically perforated bricks with and without filling, solid bricks.

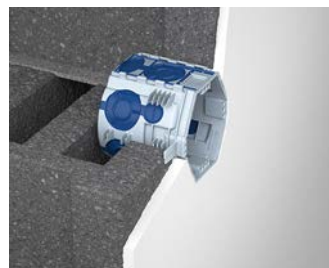

Lightweight concrete.



Cellular concrete.

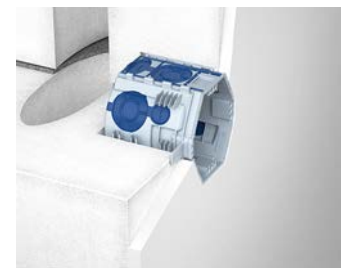

Lime sand brick.

UP¹ one-gang boxes, UP¹ one-gang junction boxes for flush-mounting installation

Processing instructions



All UP¹ one-gang boxes offer generous installation space for convenient accommodation of cables, connection terminals and installation accessories.



Overlapping box diameters allow for a stable combination and open through-wiring.



After plastering, connecting accessories can be implemented in many different ways,...



...this makes it possible, for example, to insert the connecting cables of pre-wired accessories, such as sockets, quickly and easily without having to connect them in the boxes first.

Secure connection with the new side-neutral combination

The safe combination with the KAISER side-neutral combination: place the boxes together – no matter which way round – and press them together. Now you have a stable combination with 71 mm standardised combination distance.



No matter which way the boxes meet...

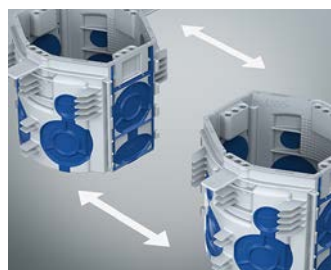

...put them together...



...and the boxes lock together stably.



Stable and side-neutral combination in 71 mm standardised combination distance.

Processing instructions – Entries



Due to entries being close to the base, the cable can be stowed directly on the base and take up little space.

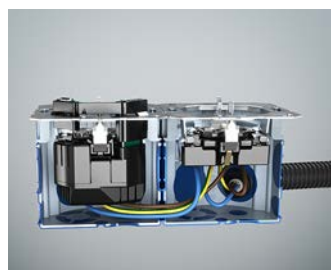

Maximum usable space, thanks to fully insulated through-wiring close to the base.



Maximum flexibility thanks to three feeds up to M25 from one direction...



...e.g. next to door openings.



The UP¹ boxes also have entries in the base...

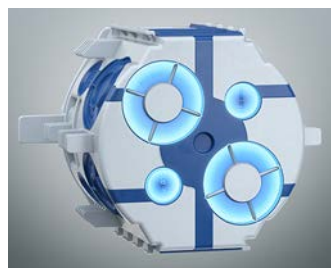

...2 entries each up to Ø 11 mm and 2 entries each up to Ø 25 mm with stiffening against pressure from expanding PU foam.



All cable and ECON® Multi-Membranes are labelled...



...this makes it easier to select the optimal entry.

UP¹ one-gang boxes, UP¹ one-gang junction boxes

for flush-mounting installation

Processing instructions for the ECON[®] Multi-Membrane



The toolless cable and conduit entries reduce installation time and make processing easier.



The elastic ECON[®] Multi-Membrane fits air-tight around the conduit or cable.

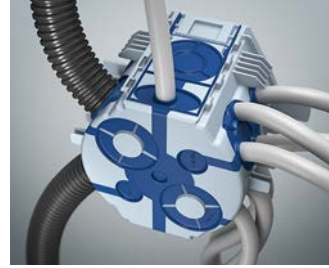

Each cable and conduit diameter up to Ø 25 mm can be installed quickly and air-tight.

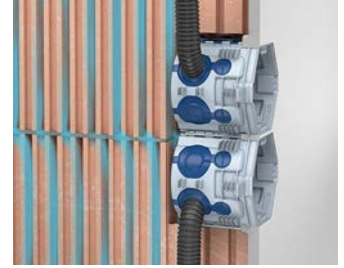

Vertical draughts occur in hollow chamber blocks. The UP¹ boxes with ECON[®] technology prevent air exchange.

Processing instructions – Combination after plastering



After plastering, connecting accessories can be implemented in four different ways:

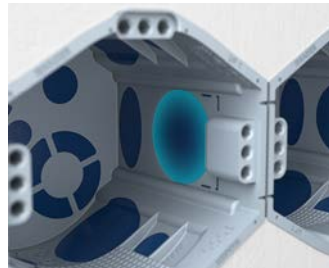

Classic connection in the middle area of the one-gang junction box...

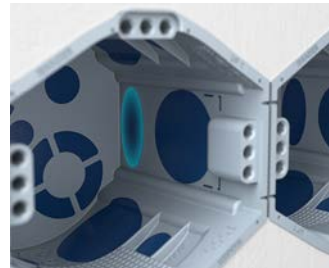

...or by the fully insulated connection close to the base in the one-gang junction boxes,...

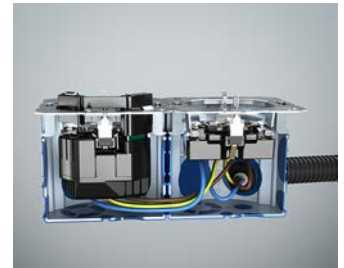

...without routing the cable in bends from one box to the other.

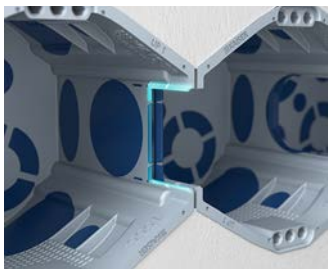

Moreover, in the case of permanently installed boxes, it is possible to break out the separator wall between the combined boxes in the upper area simply with a pair of combination pliers by means of a tilting movement...



...furthermore, the underlying ECON[®] Multi-Membrane can be additionally removed for even more wiring space.



This makes it possible to insert the connecting cables of pre-wired accessories, such as sockets, quickly and easily without having to connect them in the sockets first.



All UP¹ one-gang boxes offer generous installation space for convenient accommodation of cables, connection terminals and installation accessories.

Electrical installation

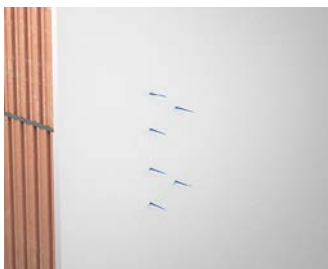

The signal bristles indicate the position of the boxes after plastering.

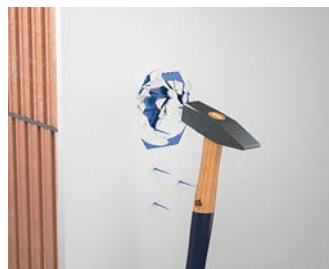

Open the boxes with one blow of the hammer.

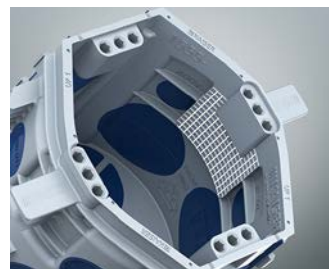

Accessory fixing by means of: expanding claws or...

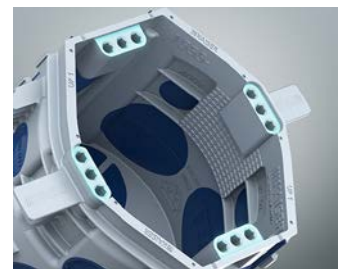

...4 x 3 screw domes for maximum flexibility.

Technical installation instructions

The quick-fixing of the UP¹ ECON[®] Fix boxes saves up to 50% installation time compared to the conventional installation of flush-mounting boxes with plaster. The box is securely fixed in the wall and held in position before plastering.

- For fitting boxes without plaster
- For all common bricks such as lime sand brick, cellular concrete, lightweight concrete, vertically perforated bricks with and without filling
- Secure, clean and time-saving
- Alignment and secure mounting even before plastering
- Can also be used at sub-zero temperatures
- By plastering the wall and allowing plaster to penetrate into the annular gap around the box, the box is finally and permanently fixed
- For thin plaster, remove the depth stop and additionally fix the boxes with flush-mounting gun foam
- Not applicable when using clay plaster

Installation advantages – Installation without plaster



The UP¹ ECON[®] Fix family with rib fixing for mounting without plaster.

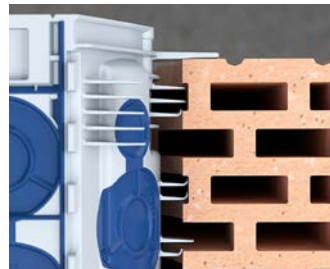

Fixing with ribs on several levels for secure fixing in all stones.



Depth stop to ensure the minimum plaster thickness.

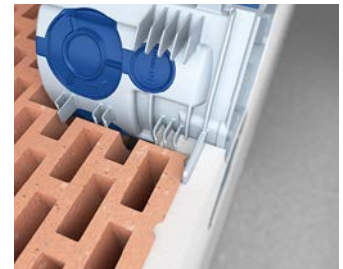

The plaster penetrates between the box and the stone, ensuring that the box is securely and permanently fixed.

Installation – Installation without plaster

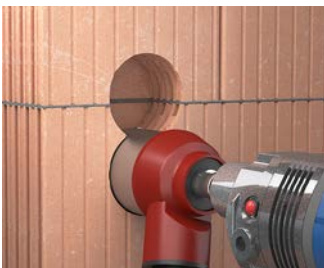

Make the installation opening Ø 82 mm with the diamond grinding head (Art. No. 1088-02).



Insert the UP¹ one-gang box or one-gang junction box with ribs.



Put on the signal cover (Art. No. 1181-65) and plaster the wall.

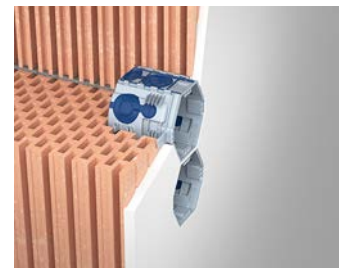

The penetration of the plaster between the box and the stone fixes the box securely and permanently.

UP¹ one-gang boxes, UP¹ one-gang junction boxes

for flush-mounting installation

Installation instructions – Installation with flush-mounting gun foam



Alternatively, the UP¹ ECON[®] Fix boxes can be fixed with flush-mounting gun foam (Art. No. 1155-95).

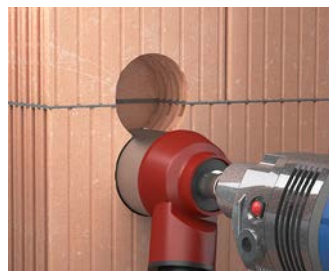

Make the installation opening Ø 82 mm with the diamond grinding head (Art. No. 1088-02).

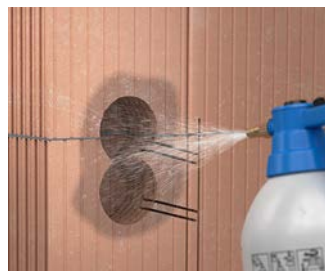

Spray the wall with water...



...and insert the UP¹ one-gang box or one-gang junction box with ribs.

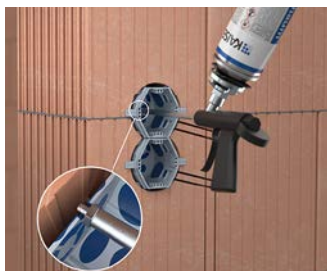

Pierce the TPE membrane in the centre of the bottom of the box...



...and foam-in the box.



If necessary, remove excess foam after curing so that plaster can still penetrate between the box and the stone.



Then fit signal cover (Art. No. 1181-65) ...



...and the wall is plastered.

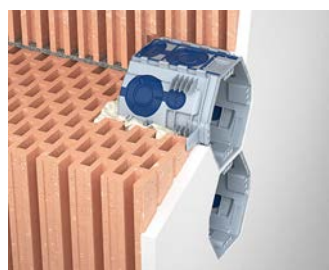

The penetration of the plaster between the box and the stone fixes the box securely and permanently.

UP¹ ECON[®] Fix one-gang box

- More volume than conventional one-gang boxes
- With quick fixing for installation without plaster
- With 4 x 3 screw domes
- Side-neutral combination
- Many through-wiring possibilities
- Standardised combination distance 71 mm

NEW



INNOVATION



3D animation

Depth	46 mm
Drill hole Ø	82 mm
With depth stop	Yes
With quick-fixing (also suitable for PU foam)	Yes
Screw spacing	60 mm
Number of screw domes	4 x 3
Tool-free line and pipe entries in the combination range up to M25	2
Toolless line and pipe entries up to M25 on the box circumference	4
Toolless cable entries up to Ø 11 mm in the bottom of the box	2
Toolless pipe entries up to M25 in the box bottom	2
Halogen-free	Yes
Air-tight	Yes
	Yes
Art.-No.	1055-26
Inner packaging/shipping	25 / 250

UP¹ ECON[®] Fix one-gang junction box

- More volume than conventional one-gang junction boxes
- With quick fixing for installation without plaster
- With 4 x 3 screw domes and 2 expanding claw fields
- Side-neutral combination
- Many through-wiring possibilities
- Standardised combination distance 71 mm

NEW



INNOVATION



3D animation

Depth	66 mm
Drill hole Ø	82 mm
With depth stop	Yes
With quick-fixing (also suitable for PU foam)	Yes
Screw spacing	60 mm
Number of screw domes	4 x 3
Splayed claw fields	2
Tool-free cable entries close to the floor up to Ø 11 mm in the combination area	2
Tool-free line and pipe entries in the combination range up to M25	2
Toolless cable entries up to Ø 11 mm on the box circumference	4
Toolless line and pipe entries up to M25 on the box circumference	4
Toolless cable entries up to Ø 11 mm in the bottom of the box	2
Toolless pipe entries up to M25 in the box bottom	2
Halogen-free	Yes
Air-tight	Yes
	Yes
Art.-No.	1555-26
Inner packaging/shipping	20 / 200



NEW

UP¹ ECON[®] electronics box and UP¹ ECON[®] two-gang junction box

The UP¹ ECON[®] electronic box and UP¹ ECON[®] double one-gang junction box extend the new UP¹ family. The UP¹ ECON[®] electronics box provides a generously-sized accessory installation space and additional space for fitting small switch actuators, etc. The matching separator wall allows the standardised installation of bus and operating voltage in one box. The UP¹ ECON[®] two-gang junction box makes it easier than ever to install special accessories. The large installation opening and the very large installation compartment make it possible to install block and pre-wired accessories, and they create space for the assembly of cables for multi-media connections.

- With quick fixing for installation without plaster
- Elastic sealing membrane for guaranteed air-tightness
- Variable and tool-free insertion of cables and DIN EN conduits up to M32
- Additional space for decentral installation of KNX / smart home UP actuators, flush-mounted cut-off relays for Venetian blinds, and many more
- Separator wall for standardised fitting of two voltage types in one box
- Maintenance of cable bending radii for network connection boxes – optimal data transfer
- Easy installation of pre-wired accessories and multi-media connection boxes



Examples of applications for the ECON[®] UP¹ electronics box



By inserting the separator wall, two different voltage types can be fitted in a standardised way in the electronics box. In addition, they provide a generously-sized installation space...



...for the decentral installation of, for example, small window actuators for controlling Venetian blinds and heating in the outer wall.



Thanks to the electronics box, it is easy to install radio-controlled actuators, etc., without putting excessive strain on cables or accessories.



Network connection boxes can be used while maintaining the cable bending radii and with the best possible data transfer speeds.

Processing instructions



The permanently elastic sealing membrane used in ECON[®] technology guarantees the airtight connection of cables up to Ø 11 mm, and conduits up to Ø 32 mm.



Two ECON[®] multi-membrane entries up to M32 enable the insertion of prefabricated cables with connectors such as HDMI.



The sealing membrane fits tightly around the cable or conduit and permanently prevents leakage in outer walls and in inner walls next to outer walls.



The peripheral sealing lip between the box body and the front part ensures an air-tight connection i.e. retention of the building's air-tight seal.

UP¹ ECON[®] Fix electronics box

- With quick fixing for installation without plaster
- With 4 x 3 screw domes
- Side-neutral combination
- Many through-wiring possibilities
- Standardised combination distance 71 mm

NEW

INNOVATION



3D animation

Length x Width x Depth	149 x 80 x 68 mm
Drill hole Ø	2 x 82 mm
With depth stop	Yes
With quick-fixing (also suitable for PU foam)	Yes
Screw spacing	60 mm
Number of screw domes	4 x 3
Device screws	2
Tool-free cable entries close to the floor up to Ø 11 mm in the combination area	3
Tool-free line and pipe entries in the combination range up to M25	3
Toolless cable and conduit entry into box shells up to M25	3
Toolless cable and conduit entry into box shells up to M32	2
Toolless cable entries up to Ø 11 mm in the bottom of the box	4
Toolless pipe entries up to M25 in the box bottom	2
Halogen-free	Yes
Air-tight	Yes
	Yes
Art.-No.	1068-26
Inner packaging/shipping	10 / 100

UP¹ ECON[®] Fix two-gang junction box

- With quick fixing for installation without plaster
- With 6 x 3 screw domes
- Side-neutral combination
- Many through-wiring possibilities
- Standardised combination distance 71 mm

NEW

INNOVATION



3D animation

Length x Width x Depth	149 x 80 x 68 mm
Drill hole Ø	2 x 82 mm
With depth stop	Yes
With quick-fixing (also suitable for PU foam)	Yes
Screw spacing	60 mm
Number of screw domes	6 x 3
Device screws	4
Tool-free cable entries close to the floor up to Ø 11 mm in the combination area	3
Tool-free line and pipe entries in the combination range up to M25	3
Toolless cable and conduit entry into box shells up to M25	3
Toolless cable and conduit entry into box shells up to M32	2
Toolless cable entries up to Ø 11 mm in the bottom of the box	4
Toolless pipe entries up to M25 in the box bottom	2
Halogen-free	Yes
Air-tight	Yes
	Yes
Art.-No.	1656-26
Inner packaging/shipping	10 / 100



Stepless plaster compensation frame UP¹

With the newly developed plaster compensation frame, even accessories in boxes that are installed too low can be installed flush with the wall and in compliance with standards. Also ideal for renovations. The plaster compensation frame is stepless adjustable and can therefore, e.g. bridge retrofitted wall plaster or tiled walls professionally.

- To compensate for boxes that are positioned too low
- Continuously adjustable from 10 - 35 mm
- Installation accessories can be installed directly with the compensation frame or retrofitted
- Including screws 40 mm, Pozidriv drive



Processing instructions



Insert the plaster compensation frame into the box.



Either mount the accessory and the plaster compensation frame together on the box with a screw...



...or first mount the plaster compensation frame and fix the installation accessory later.

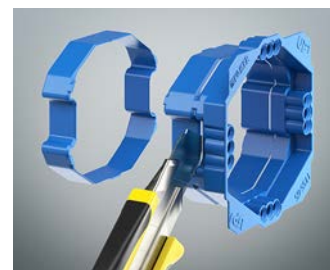

The plaster compensation frame can be shortened in segments if required.

Stepless plaster compensation frame UP¹

- To compensate for deep-seated boxes
- To maintain IP protection class
- With 2 fixing screws 40 mm

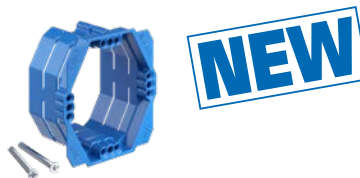

INNOVATION

Height	10 - 35 mm
Screw spacing	60 mm
Steplessly adjustable	Yes
for UP ¹ appliance outlets and UP ¹ appliance junction boxes	Yes
Halogen-free	Yes
Art.-No.	1155-65
Inner packaging/shipping	10 / 100

Signal cover UP¹

The signal cover for the new UP¹ flush mounting boxes protects the inside of the box and the screw domes during plastering, while the tried-and-tested signal bristles make it easier to find them after plastering. The soft signal bristles gently wrap around and prevent splashing when cleaning.

- Protects interior of box, screwing dome and screw heads when plastering
- Signal bristles facilitate finding after plastering
- Soft signal bristles gently wrap around and prevent splashing when plastering
- Reusable



Processing instructions



Fit signal cover (Art. No. 1181-65).



When plastering, the soft signal bristles wrap around without splashing and at a later time, indicate the position of the box.



After opening with one blow of the hammer...

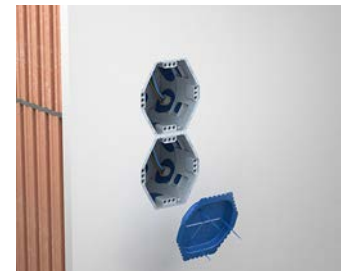

...the boxes are cleanly opened, the signal lid can be used several times.

Signal cover UP¹

- Reusable
- Protects interior of box, screwing dome and screw heads when plastering



INNOVATION

For installation opening	60 mm	2 x 60 mm
for UP ¹ appliance outlets, UP ¹ appliance junction boxes and UP ¹ electronic box	Yes	-
for UP ¹ two-gang junction box (Art. No. 1656-26)	-	Yes
Art.-No.	1181-65	1181-16
Inner packaging/shipping	50 / 1000	- / 50

Flush-mounting gun foam

- For additional fixing of the UP¹ ECON[®] Fix boxes
- For processing with commercially available PU foam guns with M65 threaded connection
- Can be used with Art. No. 1055-26, 1555-26, 1068-26 and 1656-26
- 1-component PU foam
- Building material class E according to EN 13501 (DIN 4102 B2 quality)
- Fine-pored foam structure
- Ambient processing temperature -10°C to +30°C, optimum +20°C, 60% relative humidity (box temperature min. +5°C)
- Humidity curing / Adhesive-free within approx. 10 min
- Can be cut after approx. 30 min. / Fully loadable after approx. 12 h
- Temperature resistant cured from -40 °C to +80 °C
- Can be stored up to 12 months / Please note the safety data sheet

INNOVATION



Contents	750 ml
Art.-No.	1155-95
Inner packaging/shipping	- / 12

Subject to modifications



Flush-mounting installation boxes

With the innovative KAISER UP-PLUS technology, the flush-mounting range impresses with a PLUS in terms of fitting convenience and flexibility. This range with the practical combination connection piece for quick, safe combinations ensures a torsion-proof pluggable connection for combinations with the snap-in connector, as well as a guaranteed standardised combination distance of 71 mm. The variable combination connection pieces are suitable for M20/M25 conduits and cables, and are standard for KAISER flush-mounting boxes. There are further entries for M20/M25 conduits and cables around the circumference of the box, as well as an entry for M20 conduits or cables at the bottom of the box. Four screw domes and two expanding claw fields offer secure, flexible mounting options for all types of devices, and thus round off the flush-mounting range.

- Variable combination connection piece for conduits up to M25 and cables
- Snap-in connector for torsion-proof and guaranteed standardised combination distance of 71 mm
- Flexible for screw and expanding claw fixing
- Optimum installation space
- UP-PLUS – with distance support, tunnel connector and KLEMMFIX® for quick, secure installation



Entries for cables and DIN EN conduits



Secure combination with the combination connection piece

An audibly secure combination with the KAISER combination connection piece. Place the boxes next to each other. Place the centering piece in the groove and press together until you hear a „click“. Now you have a torsion-proof combination with a standardised combination distance of 71 mm.



One-gang box

- dimensions in accordance with German DIN 49073
- For M20/M25 conduits and cables



Product-Data

Depth	46 mm	46 mm
Screw spacing	60 mm	60 mm
Number of screw domes	4	4
Splayed claw fields	2	2
Conduit entries M20	3	3
Conduit entries M25	2	2
Combination conduit entries M20/25	2	2
Halogen-free	Yes	Yes
Device screws	-	2
	Yes	Yes
Art.-No.	1055-04	1056-04
Inner packaging/shipping	25 / 500	25 / 500

Flush mounting one-gang junction box

- dimensions in accordance with German DIN 49073
- For M20/M25 conduits and cables



Product-Data

Depth	66 mm	66 mm
Screw spacing	60 mm	60 mm
Conduit entries M20	9	9
Number of screw domes	4	4
Splayed claw fields	2	2
Conduit entries M25	2	2
Combination conduit entries M20/25	2	2
Halogen-free	Yes	Yes
Device screws	-	2
	Yes	Yes
Art.-No.	1555-04	1556-04
Inner packaging/shipping	25 / 250	25 / 250

One-gang junction box with side cavities for connections

- with side cavities for connections
- from above 4 x multi-lead wiring
- dimensions in accordance with German DIN 49073
- For M20/M25 conduits and cables



Length x Width x Depth	110 x 71 x 49 mm
Screw spacing	60 mm
Number of screw domes	4
Conduit entries M20	6
Conduit entries M25	4
Combination conduit entries M20/25	2
Device screws	2
Halogen-free	Yes
	Yes
Art.-No.	1069-02
Inner packaging/shipping	10 / 100

Electronics box



The electronics box has space for electronic components. The accompanying separator wall also enables you to have different kinds of voltages in one box.

- For accessories and electronic components such as EIB actuators, communication and network technology, radio-controlled elements, alarm modules, etc.
- Can be combined with KAISER one-gang boxes via snap-in connector
- Optimal for use as an entry box for combinations
- The separator wall (supplied) turns it into a twin-chamber box



Application



The range of possibilities is as diverse as their solutions.



Here for example is a relay for central control of several roller blind drives or a flush mounting EIB interface with a conventional button.



For communication equipment, the box volume is ideal for accommodating cable reserves.



Concealed installation of electronic components such as radio-controlled modules, EIB actuators, emergency lighting or cable lengths in data network technology.

Electronics box

- Twin-chamber box (with separator wall)
- dimensions in accordance with German DIN 49073
- For M20/M25 conduits and cables



Length x Depth	149 x 67 mm
Screw spacing	60 mm
Number of screw domes	4
Conduit entries M20	11
Conduit entries M25	2
Combination conduit entries M20/25	4
Device screws	2
Halogen-free	Yes
ΔE	Yes
Art.-No.	1068-02
Inner packaging/shipping	10 / 100

Air-tight flush-mounting boxes

Flush-mounting boxes with ECON® technology permit guaranteed air-tight installation. They offer a variety of options for air-tight conduit and cable entries and can be either plastered or processed using Klemmfix®. The new ECON® Multi-Membrane allows the insertion of several cables without gusset formation or the insertion of conduits up to M25.

- Air-tight design with ECON® sealing membranes
- Avoids leaks in exterior facades made from hollow chamber blocks
- Variable and tool-free cable and conduit entries
- Torsion-proof, guaranteed standardised combination distance of 71 mm



Entries for conduits and DIN EN conduits

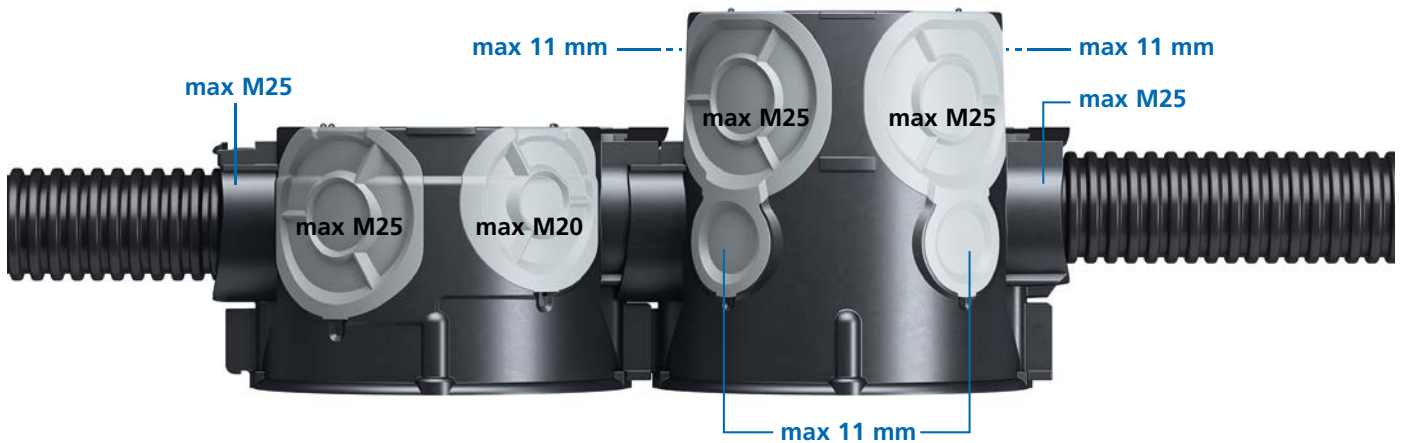

Processing instructions



The tool-free cable and conduit entries reduce installation time and make processing easier.



The elastic sealing membrane fits air-tight around the conduit or cable.



Each cable and conduit diameter up to Ø 25 mm can be installed quickly and air-tight.



Vertical draughts occur in hollow chamber blocks. The UP boxes with ECON® technology prevent air exchange.

Air-tight one-gang boxes, One-gang junction boxes

for flush-mounting installation

One-gang box ECON® 10

- Air-tight design with ECON® sealing membranes
- dimensions in accordance with German DIN 49073
- For M20/M25 conduits and cables



3D animation



Product-Data

Depth	46 mm	46 mm
Screw spacing	60 mm	60 mm
Number of screw domes	4	4
Conduit entries M20	2	2
Conduit entries M25	2	2
Tool-free cable and conduit entries in the connector area up to M25	2	2
Air-tight	Yes	Yes
Halogen-free	Yes	Yes
Device screws	-	2
	Yes	Yes
Art.-No.	1055-21	1056-21
Inner packaging/shipping	25 / 500	25 / 500

One-gang junction box ECON® 15

- Air-tight design with ECON® sealing membranes
- dimensions in accordance with German DIN 49073
- For M20/M25 conduits and cables



3D animation



Product-Data

Depth	66 mm	66 mm
Screw spacing	60 mm	60 mm
Number of screw domes	4	4
Splayed claw fields	2	2
Tool-free cable and conduit entries in the connector area up to M25	2	2
Tool-free cable and conduit entries up to 11 mm below the connector	2	2
Tool-free cable and conduit entries up to M25 around the box	4	4
Tool-free cable and conduit entries up to 11 mm around the box	4	4
Air-tight	Yes	Yes
Halogen-free	Yes	Yes
Device screws	-	2
	Yes	Yes
Art.-No.	1555-21	1556-21
Inner packaging/shipping	25 / 250	25 / 250

Electronics box ECON® and two-gang junction box ECON®

The electronics box and two-gang junction box using ECON® technology and a multi-membrane are ideal for installation in masonry walls in which the interior plaster forms the air-tight closure on the room side. The electronics box ECON® provides a generously-sized accessory installation space and additional space for fitting small switch actuators, etc. The matching separator wall allows the standardised installation of bus and operating voltage in one box. The two-gang junction box ECON® with a multi-membrane makes it easier than ever to install special accessories. The large installation opening and the very large installation compartment make it possible to install block and pre-wired accessories, and they create space for the assembly of cables for multi-media connections.

- Elastic sealing membrane for guaranteed air-tightness
- Variable and toolless insertion of single cables, duplex cables and DIN EN conduits
- Additional space for decentral installation of KNX / LON UP actuators, flush-mounted cut-off relays for Venetian blinds, and many more
- Separator wall for standardised fitting of two voltage types in one box
- Maintenance of cable bending radii for network connection boxes – optimal data transfer
- Easy installation of pre-wired accessories and multi-media connection boxes



Examples of applications for the ECON® electronics box



By inserting the separator wall, two different voltage types can be fitted in a standardised way in the electronics box. In addition, they provide a generously-sized installation space...



...for the decentral installation of, for example, small window actuators for controlling Venetian blinds and heating in the outer wall.



Thanks to the electronics box, it is easy to install radio-controlled actuators, etc., without putting excessive strain on cables or accessories.



Network connection boxes can be used while maintaining the cable bending radii and with the best possible data transfer speeds.

Air-tight one-gang boxes, one-gang junction boxes for flush-mounting installation

Examples of applications for the two-gang junction box ECON®



Thanks to its large installation opening without a central bridge, the two-gang junction box allows...



...the use of pre-wired accessories, block inserts, and many more.



It also provides an easy-to-use basis for the installation of multi-media connection boxes. The very large installation compartment has plenty of space for cable assembly.



Cable reserves and connection plugs can easily be inserted into the box and are then concealed behind the installation accessories.

Installation and connection option with distance support



Two-row combination with the two-gang junction box ECON® (Art. No. 1656-21) with two distance supports (Art. No. 1159-34)...



...for an optimised installation pattern (4-fold next to each other).



Two-row combination with the two-gang junction box ECON® (Art. No. 1656-21) and air-tight one-gang junction boxes (Art. No. 1556-21) with two distance supports (Art. No. 1159-34)...



...for an optimised installation pattern (6-fold next to each other).

Electronics box ECON®

- Separator wall for electrical circuit separation
- Air-tight design with sealing membranes



Two-gang junction box ECON®

- Air-tight design with sealing membranes



Length x Width x Depth	149 x 80 x 68 mm	149 x 80 x 68 mm
Screw spacing	60 mm	60 mm
Number of screw domes	4	6
Device screws	2	4
Cable entries up to Ø 11 mm	4	4
Duplex cable entries 2 x up to 11 mm	4	4
Conduit entries M25	4	4
Tool-free cable and conduit entries in the connector area up to M25	4	4
Halogen-free	Yes	Yes
	Yes	Yes
Art.-No.	1068-21	1656-21
Inner packaging/shipping	10 / 100	10 / 100

Sealing inserts

The sealing insert ensures air-tight closing of previously-installed one-gang boxes and one-gang junction boxes. It can be used in both flush-mounting and cavity wall installation. Its low installation depth makes use in one-gang junction boxes possible without restricting the wiring.

- Ensures later air-tight closing of one-gang boxes and one-gang junction boxes
- Toolless connection wire penetration is possible
- Guarantees later and permanent air-tightness



Application



Later air-tight closing of flush-mounting boxes.

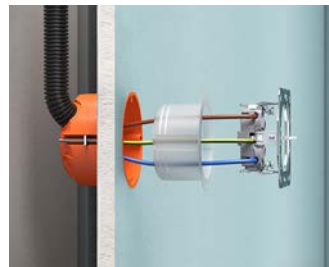

Later air-tight closing of cavity wall boxes.



Pre-punched entry markings permit toolless connection wire penetration up to 2.5 mm².



Press sealing insert and installation accessories into the box and tighten with device screws.

Sealing inserts

Sealing insert for retrofit sealing of existing installation boxes in air-tight building shells. The insert encloses the cables and creates a guaranteed air-tight installation space.

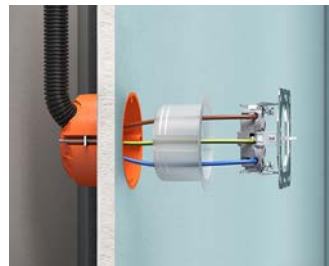

Sealing inserts

- for retrofit sealing of all existing one-gang boxes and one-gang junction boxes
- permanently flexible plastic



Depth	36,5 mm
Diameter	60 mm
Air-tight	Yes
Halogen-free	Yes
Art.-No.	1040-01
Inner packaging/shipping	10 / 100



Sealing plugs 16-40

Sealing plugs with ECON® technology for sealing all standard electrical installation conduits in installation boxes or at cable outlets. The long sealing plug with three sealing lips and in different widths adapts itself to the installation conduit in use and guarantees air-tight and smoke-tight closing, even when the conduits are cut at an angle. From conduit size M25 and up, the membrane surfaces are separated by bridges, which ensure secure cable routing and prevent damage and gaps between cables.

- For empty conduit installations in an air-tight design or in fire protection areas
- Sealing plug with three sealing lips and different widths adapts itself perfectly to the installation conduit and guarantees an air-tight end
- Elastic sealing membrane for guaranteed air-tightness
- Toolless cable entry
- Reinforcing ribs in the membrane ensure air-tightness for the cables
- For all installation conduits M16 - M40, Pg 9 – Pg 36, 3/4" and 5/8"



Processing instructions



The long sealing plug with three sealing lips and different widths adapts itself perfectly to the installation conduit...

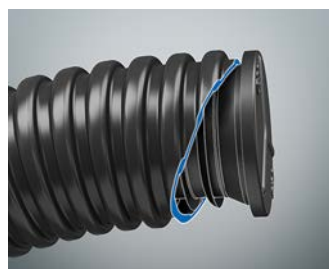

...and guarantees an air-tight end even when conduits are cut at an angle.

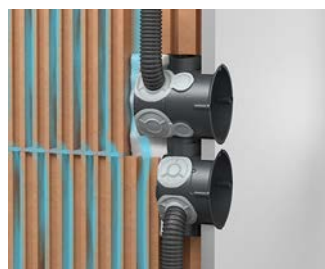

When air-tight installation is necessary, the sealing plugs prevent leakage at the conduit ends.



For installations in the field of fire protection, the sealing plug closes the conduit ends and ensures smoke-tight room separation.

Assignment of conduit sizes and sealing plugs

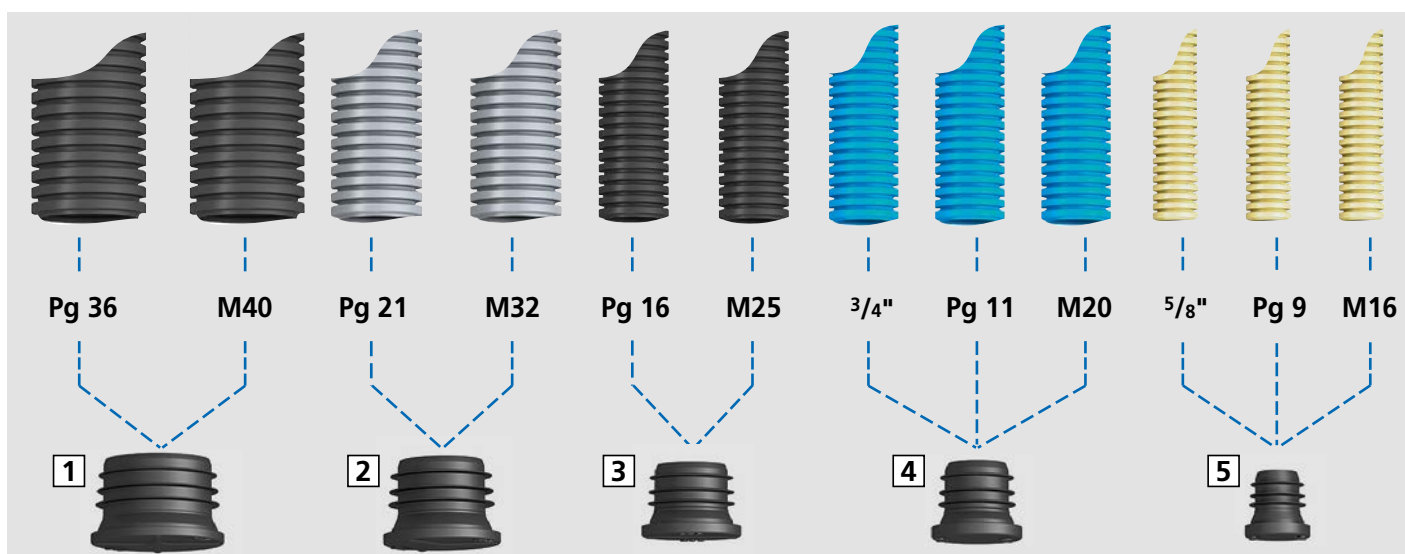

1 Sealing plug M40 Art. No. 1040-40 | **2** Sealing plug M32 Art. No 1040-32 | **3** Sealing plug M25 Art. No 1040-25 | **4** Sealing plug M20 Art. No 1040-20 | **5** Sealing plug M16 Art. No 1040-16

Sealing plugs 16-20

- for sealing electrical installation conduits
- ECON® technology for easy cable entry
- permanently flexible plastic



3D animation

Sealing plug	M16	M20
DIN EN conduit Ø	16 mm	20 mm
Halogen-free	Yes	Yes
Art.-No.	1040-16	1040-20
Inner packaging/shipping	25 / 100	25 / 100

Sealing plugs 25-40

- for sealing electrical installation conduits
- ECON® technology for easy cable entry
- permanently flexible plastic



3D animation

Sealing plug	M25	M32	M40
DIN EN conduit Ø	25 mm	32 mm	40 mm
Halogen-free	Yes	Yes	Yes
Art.-No.	1040-25	1040-32	1040-40
Inner packaging/shipping	25 / 100	25 / 50	- / 25

Two-gang junction box

- can also be used as a one-gang junction box (incl. 2 device inserts)
- for use as a junction box cover Art. no. 9062-90 is additionally needed
- use separator wall to separate electrical circuits Art. No. 1656-22 (not illustrated)
- dimensions in accordance with German DIN 49073



Length x Width x Depth	140 x 60 x 42 mm	140 x 60 x 42 mm
Conduit entries M20	12	12
Combination distance	71 mm	71 mm
Halogen-free	Yes	Yes
Device screws	-	4
	Yes	Yes
Art.-No.	1655-02	1656-02
Inner packaging/shipping	10 / 100	10 / 100

One-gang boxes, One-gang junction boxes for flush-mounting installation

One-gang box

- with nail straps as fitting aid
- nail Ø max. 3 mm
- plaster depth min. 6 mm
- dimensions in accordance with German DIN 49073
- for M20 conduits



Depth	42 mm	42 mm
Screw spacing	60 mm	60 mm
Conduit entries M20	7	7
Halogen-free	Yes	Yes
Device screws	-	2
	Yes	Yes
Art.-No.	1055-62	1056-62
Inner packaging/shipping	- / 100	- / 100

Cavity wall one-gang junction box

- with nail straps as fitting aid
- nail Ø max. 3 mm
- plaster depth min. 6 mm
- dimensions in accordance with German DIN 49073
- for M20 conduits



Depth	63 mm	63 mm
Screw spacing	60 mm	60 mm
Conduit entries M20	13	13
Halogen-free	Yes	Yes
Device screws	-	2
	Yes	Yes
Art.-No.	1555-62	1556-62
Inner packaging/shipping	- / 100	- / 100

One-gang box without support

- for use in facing masonry
- for combinations: use supports Art. No. 1159-01
- dimensions in accordance with German DIN 49073
- for M20 conduits



Depth	42 mm	42 mm
Screw spacing	60 mm	60 mm
Conduit entries M20	7	7
Halogen-free	Yes	Yes
Device screws	-	2
	Yes	Yes
Art.-No.	1050-00	1051-00
Inner packaging/shipping	25 / 500	25 / 500

One-gang junction box without support

- for use in facing masonry
- for combinations: use supports Art. No. 1159-01
- dimensions in accordance with German DIN 49073
- for M20 conduits



Depth	63 mm	63 mm
Screw spacing	60 mm	60 mm
Conduit entries M20	13	13
Halogen-free	Yes	Yes
Device screws	-	2
	Yes	Yes
Art.-No.	1550-00	1551-00
Inner packaging/shipping	25 / 250	25 / 250

One-gang box PERILEX®

- for PERILEX® 16 A inserts
- only for screw fixing
- dimensions in accordance with German DIN 49073
- for M20 conduits



Depth	48 mm
Screw spacing	67 mm
Device screws	2
Conduit entries M20	8
Halogen-free	Yes
Art.-No.	1076-04
Inner packaging/shipping	10 / 100

One-gang box CEE

- for CEE 16 A connectors
- only for screw fixing
- with sealing ring, protection class IP3X
- dimensions in accordance with German DIN 49073
- For M20/M25 conduits and cables



Depth	50 mm
Screw spacing	67 mm
Raised head accessory screws 4 mm	Yes
Conduit entries M20	2
Conduit entries M25	2
Halogen-free	Yes
	Yes
Art.-No.	1075-04
Inner packaging/shipping	- / 100

Junction boxes

for flush-mounting installation

Junction box

- with nail straps as fitting aid
- nail Ø max. 3 mm
- plaster depth min. 6 mm
- without cover and cover screws
- dimensions in accordance with German DIN 49073
- for M20 conduits



Depth	36 mm
Screw spacing	67 mm
Conduit entries M20	8
For 6 terminals 1.5 mm ² or 5 terminals 2.5 mm ²	Yes
Halogen-free	Yes
	Yes
Art.-No.	1172-62
Inner packaging/shipping	- / 100

Junction box

- KLEMMFIX® mounting possible
- according to German DIN VDE 0606, junction box covers may only be removable using tools
- dimensions in accordance with German DIN 49073
- for M20 conduits



Depth	36 mm	36 mm
Screw spacing	67 mm	67 mm
Conduit entries M20	8	8
For 6 terminals 1.5 mm ² or 5 terminals 2.5 mm ²	Yes	Yes
For mounting with Klemmfix® (Art. No. 1159-12)	Yes	Yes
Halogen-free	Yes	Yes
With cover and 2 cover screws	-	Yes
	-	Yes
Art.-No.	1172-02	1172-92
Inner packaging/shipping	25 / 500	25 / 250

Junction box

- with plaster disc, cover and cover screw
- KLEMMFIX® mounting possible
- For M20 conduits and cables up to 5 x 2.5 mm²



Depth	36 mm
Screw spacing	67 mm
Conduit entries M20	8
For 6 terminals 1.5 mm ² or 5 terminals 2.5 mm ²	Yes
without terminal block	Yes
Halogen-free	Yes
	Yes
Art.-No.	1172-09
Inner packaging/shipping	25 / 100

Junction box

- for 8 terminals 1.5 mm², for 6 terminals 2.5 mm² or for 5 terminals 4 mm²
- without cover and cover screws
- For M16/M20 conduits



Depth	56 mm
Screw spacing	67 mm
M16-20 combination conduit entry	14
Halogen-free	Yes
	Yes
Art.-No.	1572-02
Inner packaging/shipping	10 / 250

In-plaster junction box

- for flat multi-lead wiring (NYIF) 1.5 and 2.5 mm²
- terminal block permanently attached
- with plaster disc, cover and cover screw
- Junction box fire-resistant up to 960°C, cover to 850°C in accordance with DIN EN 60670



Depth	16 mm
Screw spacing	80 mm
Terminal block, no. of poles	5
Halogen-free	Yes
	Yes
Art.-No.	1081-05
Inner packaging/shipping	25 / 250

Light connection boxes, Ceiling exits

for flush-mounting installation

Wall light connection box

- With integrated cover
- not to be used as a junction box!



Length x Width x Depth	60 x 32 x 30 mm
Break-out openings Ø 20 mm	4
Halogen-free	Yes
	Yes
Art.-No.	1048-00
Inner packaging/shipping	25 / 250

Cover

- for wall light connection boxes
Art. No. 1048-00 and Art. No. 9148-00
- With Ø 3.2 x 15 mm cover screws



Length x Width	75 x 40 mm
Halogen-free	Yes
Art.-No.	1148-90
Inner packaging/shipping	25 / 250

Luminaire connection box

- for casting into concrete ceilings
- 2 parts with snap-in connection
- sealed against concrete
- delivery unit: 1 ceiling light connection box pre-cut for DIN EN conduits 20 mm Ø, 2 reducers/stoppers for use with cable, 1 sealing plug-in cover, 1 light hook (fully-insulated) max. load 100 N (10 kg) in accordance with German VDE
- Marking for cables and DIN EN conduits up to 25 mm



Depth	55 mm
Ceiling exit (CE) Ø	35 mm
Light hook length	55 mm
Conduit entries M20	1
Halogen-free	Yes
	Yes
Art.-No.	1248-55
Inner packaging/shipping	1 / 100

Ceiling exit bush

- for multi-lead wiring (NYIF) 1.5 mm² and 2.5 mm²
- to prevent cable being ripped out



Cable entry	5,5 x 23 mm	5,5 x 23 mm
Halogen-free	Yes	Yes
With light hook and expanding dowel Ø 10 mm	-	Yes
with brass wedge nut, max. load 100 N (10kg) to German VDE norm	-	Yes
Art.-No.	1144-00	1144-05
Inner packaging/shipping	100 / 500	50 / 250

Flush-mounting sound insulation one-gang junction box

Sound insulation box for use in solid construction sound insulation walls with stringent sound insulation requirements. The solid box body with additional sound insulation coating absorbs and reflects the sound, so that interference in adjacent rooms is excluded and the sound insulation remains intact as if no installation box were present.

- Maintains the wall's sound insulation protection
- Installation up to 5-unit combinations
- Opposing installation is also possible
- Variable combination connection piece for conduits up to M25
- Flexible for screw and claw fixing of the accessories
- Can be used with sound protection cover as a junction box



Sound insulation value R'_{w} up to **56 dB**



Examples of use



Example of installation using a switch-socket combination.



Use of an opposing sound insulation box.



Use of an opposing sound insulation box.



With sound insulation cover it can also be used as junction box.

Comparison of sound insulation

Solid wall 11.5 cm and 17.5 cm with 10 mm plaster on both sides.

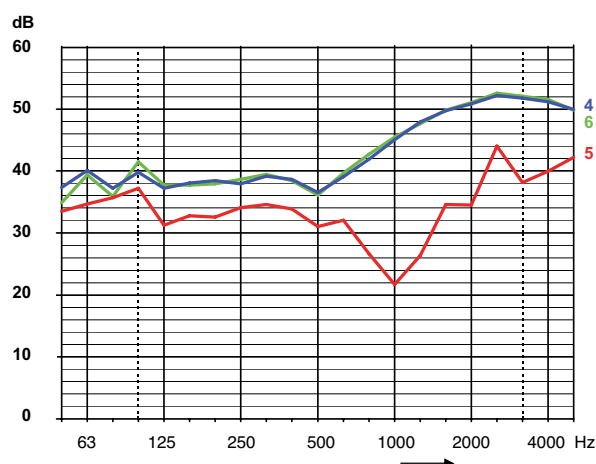
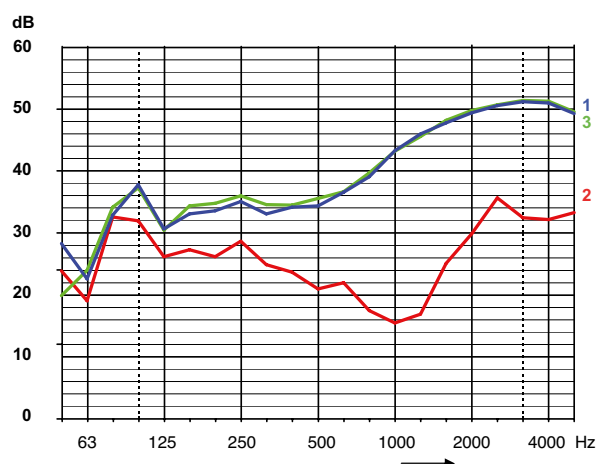

1 Wall, without installations, 52 dB | **2** with one-gang junction box 1555-04, 32 dB | **3** with one-gang junction box 1569-01, 52 dB | **4** Wall, without installations, 56 dB | **5** with one-gang junction box 1555-04, 41 dB | **6** with one-gang junction box type 1569-01, 56 dB

One-gang boxes, One-gang junction boxes for flush-mounting installation

Installation



Cut a \varnothing 82 mm installation opening using a grinding head (e.g. Art. No. 1088-15).



Make exact cable and conduit entries with the universal opening cutter (Art. No. 1085-80).



For combinations, the one-gang junction boxes are snapped together.



The sound insulation box is simply fixed with plaster.



Combinations at a standard spacing of 71 mm.



Soundproof and fully insulated through wiring is ensured by the support connectors.



Example of installation using a switch-socket combination.



With the sound insulation cover (Art. No. 1184-69), the box can also be used as junction box.

Processing instructions

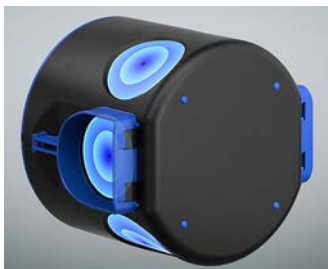

The flush-mounting sound insulation box offers 6 possible entries for conduits up to M25 and cables up to \varnothing 11.5 mm.



The support connector makes it easier to feed conduits up to M25 in the connection area.



In opposing installation, the sound insulation is guaranteed up to a five-way combination.

Allocation table for universal opening cutters



Flush-Mounting installation for sound insulation boxes		Ø setting
NYM cable	3 x 1.5 mm ²	7.5
	4 x 1.5 mm ²	8.5
	5 x 1.5 mm ² ; 3 x 2.5 mm ²	9.5
	7 x 1.5 mm ² ; 5 x 2.5 mm ²	10.5
Low-voltage cables	Integrated high voltage and MSR-Bus cable (N)Y(YSt)Y)M-J 3 x 1.5 mm ²	10.5
	EDV cable, S/STP 4 x 2 AWG23/1	7.5
	EDV cable, 100 MB S/STP 4 x 2 x AWG23/1	6.0
	Coaxial cable, double screening	6.0
	Coaxial cable, single screening	5.0
	Bus cable YCYM 2 x 2 x 0.8	5.0
	EDV cable screened, plus outer screening	5.0
	Cable for telephone and signal transmission with screening	4.0
	Telephone cable without screening	4.0
	Support connector	9060-98
Conduits according to DIN EN 60423 flexible (curled)	DIN EN 16 - Ø 16 mm	14.0
	DIN EN 20 - Ø 20 mm	17.0
	DIN EN 25 - Ø 25 mm	21.0

You can create cable entries with the prescribed strain relief easily and to the exact required size with the universal opening cutter (Art No. 1085-80).

Flush-mounting sound insulation one-gang junction box

INNOVATION



3D animation



Product-Data

- with 4 screw domes and 2 expanding claw fields
- One-gang junction box for solid construction sound insulation walls
- For conduits up to M25 and cables up to Ø 11.5 mm
- Combination distance: 71 mm



Depth	60 mm
Screw spacing	60 mm
Number of screw domes	4
Splayed claw fields	2
Tube entries up to M25	6
Cable entries of up to Ø 11.5 mm	6
for sound insulation walls up to	56 dB
Halogen-free	Yes
Art.-No.	1569-01
Inner packaging/shipping	10 / 100

Sound insulation cover

- for sound insulation box
- Sound insulation function in conjunction with sound insulation box



Diameter	92 mm
Halogen-free	Yes
	Yes
Art.-No.	1184-69
Inner packaging/shipping	10 / 100

Screened one-gang junction box



Screened one-gang junction box for flush-mounting installation. The conductive coating suppresses interference with a high alternating field component, whether radiated or received.

- For environmentally-safe electrical installation
- With screening and potential conductivity
- The functional earth of the box must only be connected to the potential equalisation and not to the equipment grounding conductor (PE conductor)

Installation



Cut an accurate wall opening (Ø 82 mm) with the diamond grinding head.

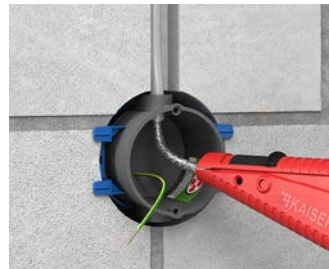

Remove cable sheath and screen with AMZ 2 (Art. No. 1190-02). Fit bare tracer wire with transparent insulating hose.



Connect functional earth of the box to tracer wires of screened cable.

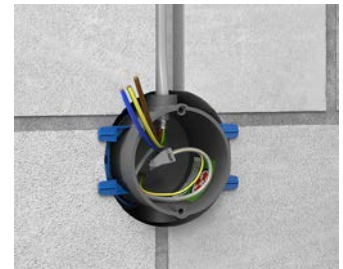

One-gang junction box is ready for installation of a socket for biological design.

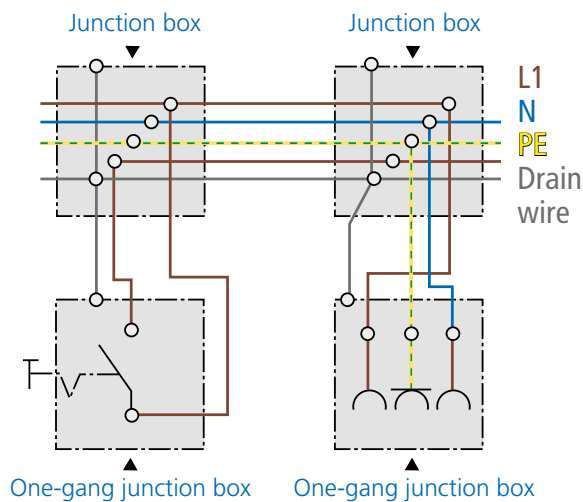

Technical processing instructions/standards

- dimensions in accordance with German DIN 49073
- for rooms used for medical purposes, environmentally-friendly construction, etc.
- the conductive coating suppresses interference with a high alternating field component, whether radiated or received
- The functional earth of the box must only be connected to the potential equalisation and not to the equipment grounding conductor (PE conductor)
- Not suitable for use in X-ray or radiation rooms!

Screened one-gang junction box

- with screening and functional earth of the box
- dimensions in accordance with German DIN 49073
- protection class IP 2X



Depth	63 mm
Screw spacing	60 mm
Cable entries 3 x 2.5 mm ² or 5 x 1.5 mm ²	6
Cable entries 3 x 1.5 mm ²	4
Halogen-free	Yes
Art.-No.	1555-88
Inner packaging/shipping	10 / 100

Screened cover

- for making screened one-gang junction boxes
- for one-gang junction boxes Art. No. 9064-88 and Art. No. 1555-88

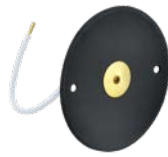

Diameter	80 mm
Screw spacing	60 mm
Art.-No.	1164-88
Inner packaging/shipping	10 / 100

Screened junction casing

- for cavity wall and flush-mounting installation
- with screened cover
- With Ø 3.2 x 15 mm cover screws
- Protection class IP 3X



Length x Width x Depth	107 x 107 x 53 mm
Cut hole Ø	4 x 35 mm
Break-out openings Ø 20 mm	8
Cable entries for NYM and low-voltage cabling	Yes
For terminals up to	4 mm ²
Art.-No.	9195-88
Inner packaging/shipping	1 / 10

Note

Other installation boxes/housings with screening available on request. Please use our radiation protection box in X-ray areas or areas with ionising radiation.

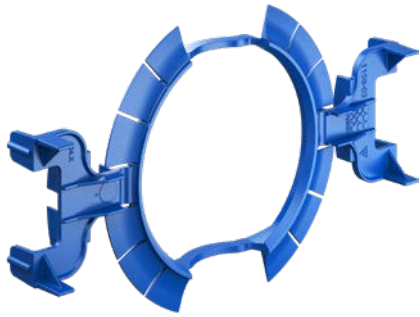

Plaster-free installation with KLEMMFIX®

The KLEMMFIX® system saves up to 50% installation time compared to the conventional installation of flush-mounting boxes with plaster. KLEMMFIX® fixes the box securely in the wall before plastering and holds it in position. No plaster, quick cement or similar is required. You no longer need to clean your tools after use. The possible health hazard caused by the use of chemicals is avoided. Storage conditions such as frost, heat, shelf life, etc. do not have to be taken into account either.

- For fitting boxes without plaster
- For all common bricks such as lime sand brick, cellular concrete, lightweight concrete, vertically perforated bricks with and without filling
- Secure, clean and time-saving
- Alignment and secure mounting even before plastering
- Can also be used at sub-zero temperatures
- By plastering the wall and allowing the plaster to penetrate into the lamella ring around the box, the box is finally and permanently fixed.
- Not applicable when using clay or thin plaster



Examples of use



Vertically perforated bricks with and without filling, solid bricks.



Light concrete.



Cellular concrete.



Lime sand brick.

Processing instructions



Fastening with lamellar ring and clamping ribs on several levels for secure fixation in all common bricks.



Depth stop to ensure minimum plaster thickness.



Designed for precisely fitting use with the KAISER flush-mounted boxes.

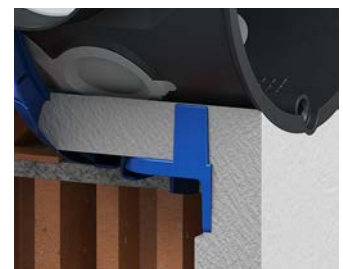

The plaster penetrates up to the lamellar ring and thus ensures that the box is securely and permanently fixed.

Installation



Make the installation opening \varnothing 82 mm with the diamond grinding crown (Art. No. 1088-02).



Push in box with KLEMMFIX® latched on.



Fit signal cover (Art. No. 1181-60).



The fine marker bristles of the signal cover indicate the exact position of the one-gang box after plastering.

Proof of stability:

Tests carried out show that all boxes remain unchanged. Long-term use in practice confirms this result. Deviations in plastering material and application of the plaster have no effect.

KLEMMFIX® for one-gang and one-gang junction boxes

- for the pre-fixing of flush-mounting boxes without plaster
- in openings made with a diamond grinding crown \varnothing 82 mm
- can be used with the UP-PLUS one-gang boxes 1055/1056-04 and one-gang junction boxes 1555/1556-04 as well as with the air-tight flush-mounting ECON® 10 1055/1056-21 one-gang boxes and ECON® 15 1555/1556-21 one-gang junction boxes



INNOVATION



3D animation



Product-Data

Cut hole \varnothing	82 mm
With depth stop	Yes
Art.-No.	1159-03
Inner packaging/shipping	25 / 250

KLEMMFIX® for junction boxes

- for the pre-fixing of flush-mounting boxes without plaster
- in openings made with a diamond grinding crown \varnothing 82 mm



For junction boxes \varnothing 70 mm (1172-02, -08, -09, -92)	Yes
Art.-No.	1159-12
Inner packaging/shipping	25 / 250

Wall groove clip

NEW

- For laying cables or conduits without plaster
- Quick fixation in wall grooves from 20 to 55 mm
- Reduction of assembly time
- No damage to the cables
- Optional: use of steel nails Ø 3 mm



Length x Width	60 x 40 mm
Art.-No.	1159-95
Inner packaging/shipping	100 / 1000

Signal cover

- Reusable
- protects interior of box, screwing dome and screw heads when plastering



For installation opening	35 mm	60 mm	70 mm	-
Length x Width	-	-	-	131 x 60 mm
For one-gang boxes and one-gang junction boxes 60 mm Ø	-	Yes	-	-
For junction boxes, PERILEX® boxes and CEE one-gang boxes Ø 70 mm	-	-	Yes	-
For two-gang junction box Art. No. 1656-02/1655-02	-	-	-	Yes
Art.-No.	1181-35	1181-60	1181-70	1181-56
Inner packaging/shipping	- / 50	50 / 1000	25 / 250	- / 50

Signal cover

- Reusable
- protects interior of box, screwing dome and screw heads when plastering



Length x Width	80 x 80 mm	100 x 100 mm	60 x 32 mm
For wall light connection boxes Art. No. 1048-00	-	-	Yes
Art.-No.	1181-94	1181-95	1181-48
Inner packaging/shipping	- / 50	- / 50	- / 100

Distance supports

- For combination distance 91 mm, e.g. for antenna sockets, telephone boxes or EDP connection boxes with sockets which are not touch-safe.



Art.-No.	1159-34
Inner packaging/shipping	25 / 100

Tunnel connector

- For fully-insulated floor through-wiring of one-gang junction boxes Art. Nos. 1555/56-04, 1555/56-21, 1068-02, 1068-21 and 1656-21



Art.-No.	1159-36
Inner packaging/shipping	10 / -

Plaster compensation rings

- to compensate for deep-seated boxes
- To maintain IP protection class
- with 2 screwed-in device screws
- with 2 ring attachment screws



Height	12 mm	24 mm	12 mm	24 mm
Screw spacing	60 mm	60 mm	67 mm	67 mm
For all one-gang boxes and one-gang junction boxes Ø	60 mm	60 mm	-	-
For junction boxes Ø	-	-	70 mm	70 mm
	Yes	Yes	Yes	Yes
Art.-No.	1155-61	1155-62	1155-71	1155-72
Inner packaging/shipping	25 / 250	25 / 250	10 / 100	10 / 100

Universal VDE cover

- for all one-gang, one-gang junction and junction boxes
- with central exit for light hook
- flat cover edge
- surface roughened



Diameter	92 mm	92 mm
Screw spacing	60 / 67 mm	60 / 67 mm
Fireproof	850 °C	850 °C
Halogen-free	-	Yes
	Yes	Yes
Art.-No.	1184-90	1184-77
Inner packaging/shipping	25 / 250	25 / 250

Universal waterproof cover

- central entry with stoppers
- for countersunk screws Ø 4 mm



Diameter	90 mm	90 mm
Screw spacing	67 mm	60 mm
Fireproof	850 °C	850 °C
Halogen-free	Yes	Yes
Art.-No.	1174-99	1174-98
Inner packaging/shipping	10 / -	10 / -

Spring cover

- With permanent elastic spring



Diameter	72 mm	85 mm	95 mm
for boxes Ø	60 mm	70 mm	80 mm
Art.-No.	1159-25	1174-25	1184-25
Inner packaging/shipping	50 / 500	50 / 500	25 / 250

Screw box

- suitable for fixing accessories and covers
- self-tapping Ø 3.2 mm
- corrosion-resistant in accordance with German DIN VDE standard
- RoHS-compliant



Length	15, 25, 40 mm
Filled with device screws +/-, 100 of each	Yes
Art.-No.	2472-91
Inner packaging/shipping	- / 8

Device screws +/-

- self-tapping Ø 3.2 mm
- Countersunk head with PZ1/S combination drive
- surface double-treated
- corrosion-resistant in accordance with German DIN VDE standard



Length	15 mm	20 mm	25 mm	40 mm
Art.-No.	2472-15	2472-20	2472-25	2472-40
Inner packaging/shipping	100 / 10000	100 / 10000	100 / 10000	100 / 10000

Sealing screws

- in pure brass
- self-tapping Ø 3.2 mm
- with cross-hole in the screw head through which sealing wire can be pulled



Length	15 mm	40 mm
Art.-No.	2444-15	2444-40
Inner packaging/shipping	100 / 1000	100 / 1000

Junction casings

Flush-mounting junction casings in all sizes and for almost any kind of jobs. This programme features practical housing sizes as well as robust housing design perfect for building sites.

- As central junction casings for star-shaped cable laying
- Easy to rewire when changing the way rooms are used
- With separator walls to separate electrical circuits
- For installation of DIN terminal strips, TS 35 standard rails for terminal blocks, LSA+ terminal strips and much more
- End cover with screw fastening for VDE-compliant installation



Processing instructions



Space for installation of TS 35 standard rails for the installation of terminal blocks, terminal installation devices etc.



Space for installation of LSA+ terminals for distribution of telecommunication equipment.

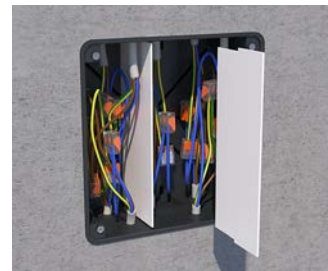

Several electrical circuits can be safely separated in one casing using separator walls that can be inserted.

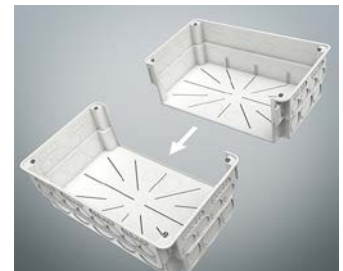

After breaking out a side wall, the casings (Art. No. 1092-90) can be clipped together and expanded to twice the size.

Junction casing 80

- for max. 2 circuits using separator wall
- suitable for installation of DIN terminal strips, TS 35 standard rails for terminal strips, terminal blocks up to 16 mm², etc.
- including cover



Length x Width x Depth	87 x 87 x 60 mm	87 x 87 x 60 mm
Conduit entries M20	8	8
Cable entries from top	16	16
For terminals up to	4 mm ²	4 mm ²
Halogen-free	-	Yes
	Yes	-
Art.-No.	1094-91	1094-01
Inner packaging/shipping	- / 100	- / 100

Junction casings

for flush-mounting installation

Junction casings 100 / 150

- for max. 2 circuits using separator wall
- suitable for installation of DIN terminal strips, TS 35 standard rails for terminal strips, terminal blocks up to 16 mm², etc.
- including cover



Length x Width x Depth	107 x 107 x 57 mm	107 x 107 x 57 mm	159 x 159 x 75 mm	159 x 159 x 75 mm
M16 conduit entries	4	4	-	-
Conduit entries M20	12	12	16	16
Conduit entries M25	4	4	8	8
Cable entries	12	12	12	12
For terminals up to	6 mm ²	6 mm ²	16 mm ²	16 mm ²
Halogen-free	-	Yes	-	Yes
M32 conduit entries	-	-	4	4
	Yes	-	Yes	-
Art.-No.	1095-91	1095-01	1096-91	1096-01
Inner packaging/shipping	- / 100	- / 100	- / 30	- / 30

Junction casing

- suitable for installation of DIN terminal strips, TS 35 standard rails for terminal strips, terminal blocks up to 16 mm², etc.
- including cover



Length x Width x Depth	240 x 142 x 87 mm	238 x 208 x 68 mm
Conduit entries M20	24	20
Conduit entries M25	12	8
M32 conduit entries	6	4
Cable entries	12	-
For terminals up to	16 mm ²	16 mm ²
Halogen-free	Yes	Yes
Suitable for standard equipment with 70 mm installation height	Yes	-
Casings can be combined once with each other, dimensions are then	240 x 284 x 87 mm	-
For max. 4 electrical circuits using separator walls	Yes	-
Maximum of 3 electrical circuits with separator walls	-	Yes
	Yes	Yes
Art.-No.	1092-90	1097-92
Inner packaging/shipping	- / 10	- / 10

Potential equalisation casing 10² and 16²

- for bathrooms or similar
- including equipotential bonding busbar, corrosion protected
- including cover



Length x Width x Depth	107 x 107 x 57 mm	238 x 208 x 68 mm
Circular conductor 6–16 ² , also uncut	1	-
Cables 1.5–10 ² (for bathrooms or similar)	6	-
Cables up to 16 ² , single and stranded wire	-	7
Circular conductors Ø 8–10 mm	-	1
Flat strip up to 30 mm wide	-	1
	-	Yes
Art.-No.	1095-73	1097-75
Inner packaging/shipping	- / 10	- / 1

Note

Other earthing products can be found at our website.

Replacement cover

- flat cover edge
- surface roughened



For casing size - flush-mounting boxes	Fire-proof	For casing size - concrete construction boxes	For casing size - cavity wall boxes	Art.-No.	Inner packaging/shipping
87 x 87 mm	650 °C	-	-	1094-13	10 / 450
107 x 107 mm	650 °C	-	-	1095-13	10 / 500
159 x 159 mm	650 °C	-	-	1096-13	10 / 200
107 x 107 mm	850 °C	128 x 128 mm	105 x 105 mm	1095-93	10 / 500
159 x 159 mm	850 °C	180 x 180 mm	165 x 165 mm	1096-93	10 / 200
240 x 142 mm	850 °C	-	238 x 142 mm	1092-93	5 / -
238 x 208 mm	850 °C	250 x 220 mm	235 x 205 mm	1097-93	5 / 100
240 x 284 mm	850 °C	-	-	1092-95	5 / -

Separator walls

- for junction casings
- can be retrofitted to separate electrical circuits



for casing size	Fireproof	Halogen-free	Art.-No.	Inner packaging/shipping
87 x 87 mm	650 °C	Yes	1094-20	10 / -
107 x 107 mm	650 °C	Yes	1095-20	10 / -
159 x 159 mm	650 °C	Yes	1096-20	10 / -
238 x 208 mm	650 °C	Yes	1097-22	10 / -
240 x 142 mm	650 °C	Yes	1092-20	10 / -

Universal installation housings

for flush-mounting installation



Universal installation housings

Universal installation housings for a wide range of device installations always ensure optimum installation space for all kinds of devices. The intelligent housing design of all six housings ensures stability and secure hold in the wall.

- For displays, LED lights and much more
- For installing almost all shapes and sizes
- Mineral fibreboard allows individual installation opening



Examples of use



Installation



Make an appropriate wall opening, feed the cables and conduits into the housing and fasten it (using plaster) in the wall.



You can create the installation opening before or after inserting the housing. The equipment is attached by simply clamping it in or screwing it into the mineral fibreboard.



Use only screws that go into but not through the mineral fibreboard when attaching the device! (e.g. SPAX countersunk head screw 3.5 x 15 mm)!

Note

Observe the maximum stroke length of the saw blade when sawing the installation opening.

Universal installation housing with mineral fibreboard

- two-part, consisting of a housing and a mineral fibreboard cover
- all-round groove indicates the maximum opening size



Length x Width x Depth	87 x 87 x 75 mm	107 x 107 x 72 mm	159 x 159 x 90 mm
Conduit entries M20	10	14	20
Cable entries	16	12	-
Universal opening size up to max.	57 x 57 mm	77 x 77 mm	129 x 129 mm
For devices with an installation depth of max.	60 mm	60 mm	75 mm
M16 conduit entries	-	4	-
Conduit entries M25	-	4	10
M32 conduit entries	-	-	4
Art.-No.	1094-22	1095-22	1096-22
Inner packaging/shipping	- / 10	- / 10	- / 10

Universal installation housing with mineral fibreboard

- two-part, consisting of a housing and a mineral fibreboard cover
- all-round groove indicates the maximum opening size



Length x Width x Depth	240 x 142 x 102 mm	240 x 280 x 102 mm	238 x 208 x 83 mm
Conduit entries M20	24	36	20
Conduit entries M25	12	16	8
M32 conduit entries	6	10	4
Cable entries	16	12	-
Universal opening size up to max.	199 x 102 mm	189 x 240 mm	198 x 168 mm
For devices with an installation depth of max.	90 mm	90 mm	70 mm
Art.-No.	1092-27	1092-28	1097-28
Inner packaging/shipping	- / 10	- / 10	- / 10

My housing. Made just for me!

You manufacture modern operating elements for building technology, or sensitive control panels for industrial equipment? For concrete, masonry or cavity walls?

We have the housing solution that you need!

- A high-quality, flexible, plastic housing.
- Developed on the basis of our many years of experience in plastics technology.
- Whatever dimensions your product has, we will create the best possible shape!
- Look for yourself – it couldn't be easier!



Configure the housing you need the configurator on our website makes it possible: www.myhousing.eu



Interior Insulation box



One-gang junction box for electrical installations in internal insulation systems. For permanently secure and heat-bridge-free installation of switches, sockets and other devices in internally insulated exterior walls. For optimal room climate with proven protection from moisture damage. For use in many internal insulation systems.

- For installation in insulated interior walls
- Guarantees installation without heat bridges
- Moisture regulating and insulating
- Prevention of moisture induced structural damage
- Suitable for use in many insulation systems
- For insulation thicknesses 30 to 100 mm
- Installation on masonry without plaster



Examples of use



Historically significant facades in exposed masonry or stucco facades.



Facade of a listed half-timbered house.



Suitable for e.g. diffusion-open insulation systems made of mineral insulation materials.



Can be used in existing masonry with different insulation thicknesses.

Specially developed for expert installation in diffusion-open internal insulation systems.

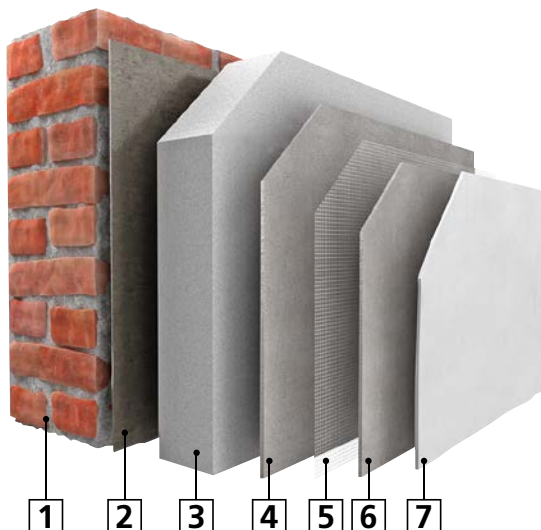

1 Masonry wall | **2** Adhesive | **3** Insulating board | **4** Reinforcement plaster | **5** Reinforcement fabric | **6** Reinforcement plaster | **7** Finish coat of plaster, decorative plaster

Technical information



Airtightness:

- Maintains the level of airtightness
- No air through-flow possible
- Air flow behind the insulation system is prevented
- No convection
- No entry of mould spores



Heat insulation:

- No heat bridge
- Room heat enters the box not the cold wall
- Insulation component replaces function of the insulation system

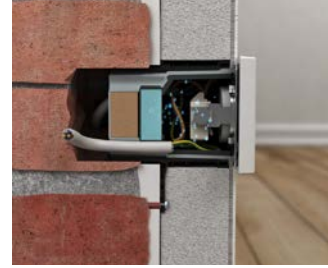

Moisture regulation:

- Room-side moisture (caused by bad ventilation, many people in the room) is stored
- Moisture is dispersed in a targeted way
- No corrosion on the accessory terminals



Heat conductivity:

- Highly heat-conductive plastic for the inner box
- Room heat is transferred to the box
- The raised surface temperature prevents the formation of condensate

Proof of functionality

A comprehensive components test carried out by the TU Dresden – Institut für Bauklimatik – confirms demonstrably the functionality of the KAISER internal insulation box. The study of internal insulation systems with $\lambda > 0.03/\text{mK}$ in insulation thicknesses from 30 to 100 mm confirms that by using the new internal insulation box, hygrothermic damage can be excluded. The certificate can be downloaded as a pdf file from our website.



Processing instructions



Installation on masonry without using plaster or mortar.



Dimension details on the adapter allow easy adaptation to the insulation thickness.



The box allows 4 cables up to $\varnothing 11.5$ mm to be entered.



Cut exact and air-tight cable entry using a drill.

Creation of combinations



Combination of boxes by simply snapping the adapters into place.



Combination distance 71 mm by removing the premarked Edge.



Fully insulated through-wiring via support connector (Art. No. 9060-88).



Example of installation of a double socket

Assignment table for making entry openings



HSS drill		Ø setting
NYM cable	3 x 1.5 mm ²	8.0
	5 x 1.5 mm ²	9.5
	3 x 2.5 mm ²	9.5



Universal opening cutter		Ø setting
Support connector	9060-88	14
Conduits	M16	17

Installation



Determine insulation thickness, adjust fastening lugs of the Adapter.



For insulation thicknesses < 100mm, cut wall opening (Ø 82mm).



Define location on the wall and mark it.



Insert cable on rear side of adapter, fix adapter to the wall.



Insert cables into box, screw box to Adapter.



Strip cable, insert signal cover.



Apply the internal insulation around the box.



Remove signal cover and install required accessory.

Interior Insulation box

- One-gang junction box for insulated interior walls
- including attachment adapter
- rear cable entries
- circumferential airtight sealing lip
- Can be combined with each other



3D animation



Product-Data

Depth	90 mm
Adapter dimensions (LxWxD)	75 x 81 x 100 mm
for insulation thicknesses	30 - 100 mm
Device screws	2
Screw spacing	60 mm
Cable entries of up to Ø 11.5 mm	4
Support connectors for each package	3
Halogen-free	Yes
Art.-No.	1159-90
Inner packaging/shipping	5 / 50

Fixing adapter internal insulation box

- For secure fixing of the internal insulation box
- For installation on masonry
- For standard combinations 71 mm



Adapter dimensions (LxWxD)	75 x 81 x 100 mm
for insulation thicknesses	30 - 100 mm
Halogen-free	Yes
Art.-No.	1159-91
Inner packaging/shipping	5 / 50

Support connector

- For fully insulated through-wiring in combinations
- For Art. Nos. 1159-90, 1555-51, 9069-03, 9069-04 and 9074-03



Art.-No.	9060-88
Inner packaging/shipping	25 / 100

FLUSH-MOUNTING

CAVITY WALL

CONCRETE

HOUSINGS

FIRE PROTECTION

PLUGGABLE

CONNECTIVITY

CABLE GLANDS

TOOLS

SERVICE



Universal equipment carrier

Universal equipment carrier for securely attaching electrical installations in or to heat-insulating external facades. Stable attachment of external lights, sockets, motion detectors, external temperature sensors, radio receivers, anemometers, cameras, letter boxes and much more.

- Secure attachment of various equipment to or in insulated external facades.
- Prevents heat bridges
- Quick installation with snap-in connections
- For insulation thicknesses of 60 to 360 mm



Examples of use



Processing instructions

Weight-bearing load dependent on the insulation thickness. The universal equipment carrier is only suitable for vertical installation (upright)!

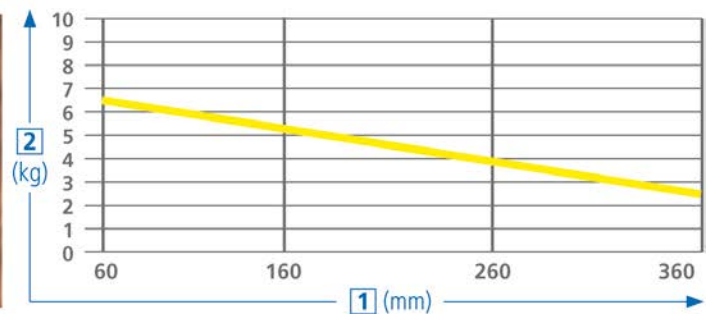
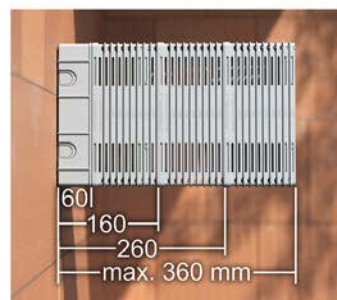
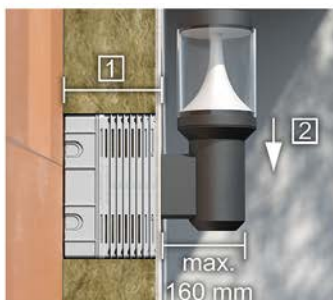

1 External insulation - insulation thickness | 2 Permissible load

Heat bridge calculation

Temp. in °C

not insulated insulated

+ 20 °C - 10 °C

When the equipment carrier is correctly installed, hardly any heat losses are measured.

Calculation and source:
PASSIV HAUS INSTITUT
Dr. W. Feist

[mm]	insulated [m ²]	not insulated [m ²]
160	0.027	0.300
360	0.039	0.520

Installation



Align the housing base vertically on the wall and screw tight using suitable fixing material.



If necessary, adjust the extension element to suit the insulation thickness.



Fit the rock wool provided. (supplied)



Fit the mounting plate (closing clip underneath) and close.

Universal equipment carrier

- for use with externally-insulated walls
- for secure fixing of lights, intercoms, motion detectors etc.
- can be extended in steps of 100 mm each (max. 360 mm) using extension elements Art. No. 1159-27
- can be reduced in 10 mm steps
- With pre-cut rock wool parts through which the equipment carrier can be fed



Product-Data

Length x Width x Height	220 x 100 x 60-160 mm
Combination conduit entries M20/25	6
Halogen-free	Yes
 650 °C / S	Yes / Yes
Art.-No.	1159-24
Inner packaging/shipping	- / 5

Extension element

- to extend the Universal equipment carrier by 100 mm simply by latching on
- can be reduced in 10 mm steps by cutting
- with rock wool pre-cut parts to fill the extension panel



Length x Width x Depth	220 x 100 x 100 mm
Halogen-free	Yes
Art.-No.	1159-27
Inner packaging/shipping	- / 5



Universal equipment carrier with combination insert

Universal equipment carrier with combination insert for the installation of entryphones and installation accessories on the insulated external facade. The perfect basis for intercoms, sockets, switches and much more, and also for two-unit and three-unit combinations.

- Guarantees installation without heat bridges
- For entryphones and variable accessory installation combinations of 1 to 3 units
- For future expansion without damaging the external facade
- For insulation thicknesses up to 360 mm



Examples of use



The product is suitable for single, double or triple combinations...

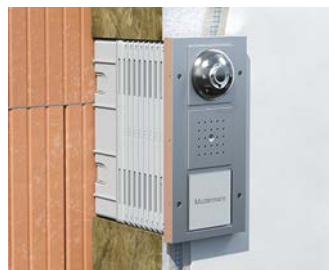

...and also permits future expansion without damage to the facade.



The equipment carrier with combination insert can be...



...mounted horizontally or vertically.

Heat bridge calculation

If installed correctly, heat losses are hardly measurable. Calculation and source: inside: +20°C, outside: -10°C | PASSIV HAUS INSTITUT Dr. W. Feist

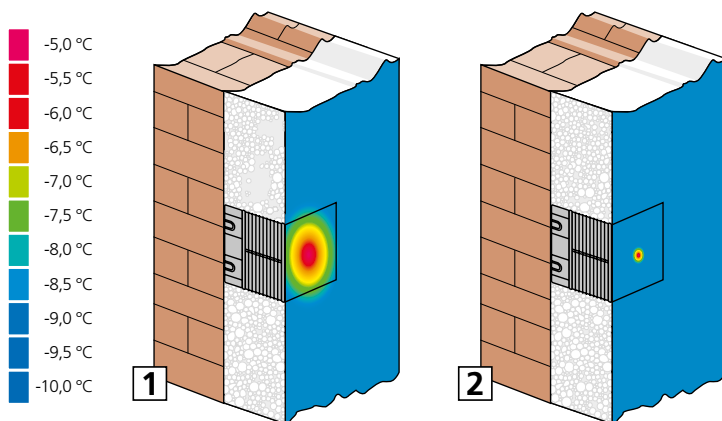

1 not insulated | 2 insulated

Installation



Define location on the wall and mark it.



Screw the housing base to the wall.



If necessary, adjust the extension element to suit the insulation thickness.



Attach the extension element and snap it into place.



Fit the rock wool insulation (supplied).



Position the combination insert (mounting clip at bottom) and snap into place.



The installation can now be fitted and installed.



After applying the plaster, attach the desired accessory.

Universal equipment carrier with combination insert

- for use with externally-insulated walls
- For secure mounting of intercoms, switches, sockets and many more
- Can be extended in steps of 100 mm using extension element
- With pre-cut rock wool parts through which the equipment carrier can be fed



3D animation



Product-Data

Length x Width x Depth	220 x 100 x 160 mm
DIN EN conduit Ø	max. 25 mm
Cable entries	max. Ø 15 mm
Insulation thickness	60 - 160 mm
Halogen-free	Yes
Art.-No.	1159-26
Inner packaging/shipping	- / 5

Extension element

- to extend the Universal equipment carrier by 100 mm simply by latching on
- can be reduced in 10 mm steps
- with rock wool pre-cut parts to fill the extension panel



Length x Width x Depth	220 x 100 x 100 mm
Halogen-free	Yes
Art.-No.	1159-27
Inner packaging/shipping	- / 5



System equipment carrier

The system equipment carrier is designed to fit perfectly into the external insulation and, in this way, reliably prevents heat bridges. Fast, easy fixing using the screw dowels included in the scope of delivery permanently anchors the equipment carrier securely to many surfaces. Ideal for stable fixing of external lamps, sockets, door intercom devices, and many more. In doing so, high weight-bearing loads are not a problem.

- Extra-fast, easy installation
- Two product types allow a wide range of applications
- Heat bridges are efficiently prevented
- Adaptable to insulation thickness in 10 mm steps – no cutting necessary
- Modular design for insulation thicknesses from 160 to 310 mm



Application examples



The system equipment carrier with combination is suitable for 1-way...



...2-way and 3-way combinations. Unused one-gang boxes can be used for future extensions without damaging the facade.



The system equipment carrier as a equipment carrier can be used as a cable exit...

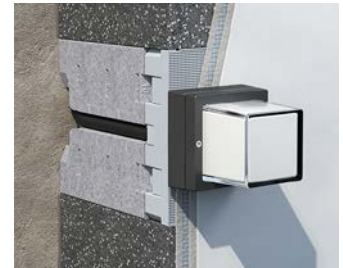

...for mounting luminaires and other accessories.

Heat bridge calculation

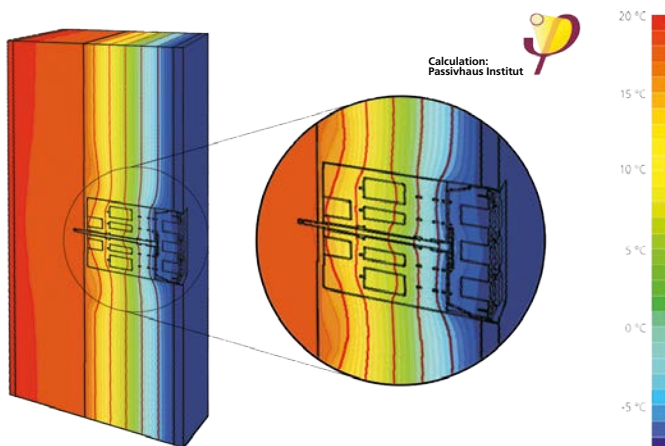

A heat bridge calculation carried out by the Passivhaus Institut in Darmstadt shows that the system equipment carrier has a point-specific heat bridge loss coefficient of $xWB < 0,01 \text{ W/K}$ and meets the requirements of a heat bridge-free facade.

Weight-bearing loads

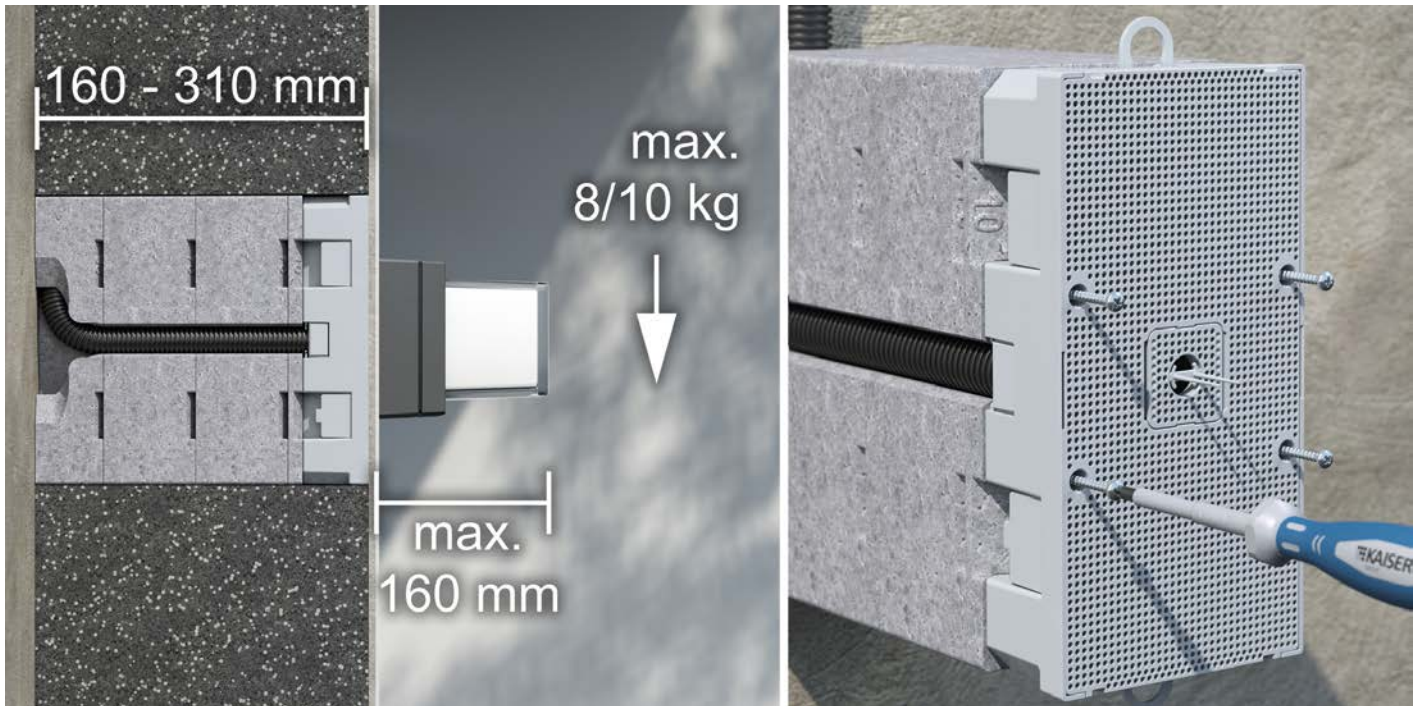

1 Weight-bearing loads – independently of the insulation thickness: For an overhang of 160 mm and insulation thicknesses of 160 - 310 mm; 8 kg without additional screwing of the front plate; 10 kg with additional screwing of the front plate. The system equipment carrier must be fitted vertically. The hole for the dowel must be drilled to make an exact fit. **2** Increasing the weight-bearing loads: To fix heavier loads, we recommend additional securing of the mounting plate by means of four Ø 3.5 x 25 screws

Versatile in use

The choice of two front parts and the modular design make the system equipment carrier a product that is extremely versatile in use. Cutting to size is not necessary because of adaptation to the insulation in 10 mm steps. Fixing by means of a single screw dowel reduces fitting time to a minimum, and at the same time, it ensures secure anchoring to the base, e.g. masonry, concrete or wood materials.

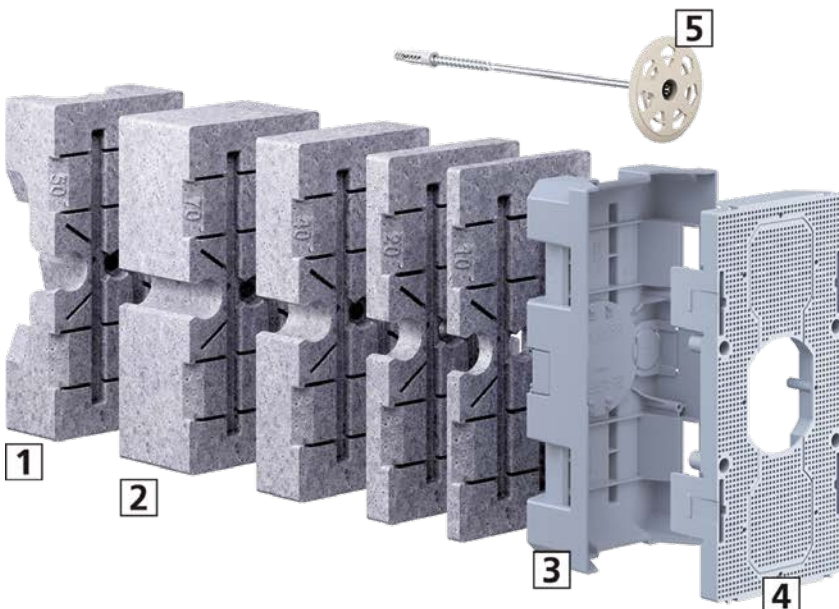

1 Basic element | **2** Intermediate elements | **3** Housing base | **4** Front plate | **5** Screw-in wall-plug

Installation



Masonry with conduit exit.

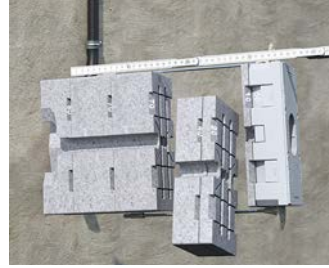

Adapt equipment carrier to insulation thickness by selecting suitable components.



Cut \varnothing 8 mm drill hole at least 50 mm deep.



Remove the side lugs from the screw dowel. Note the different lengths!

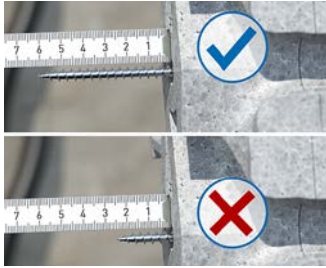

The dowel screw must protrude from the basic element by at least 40 mm.

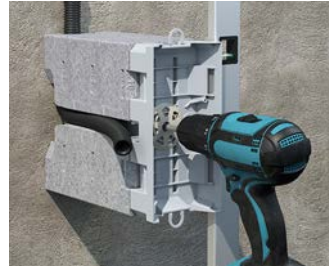

Hold the equipment carrier against the wall, align it, and fix it using the dowel.



Press the conduit into the sidewall guide and cut it to length.

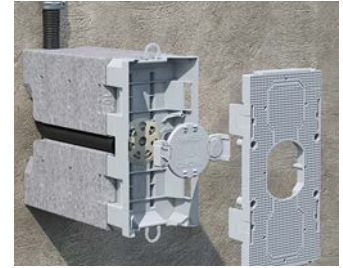

Latch on the required front part. Fit the Styrofoam cap and the dowel cover.

Tips and tricks



For an additional conduit, remove the bridges next to the Neopor® parts...



... and the perforated entry broken out in the case of the dowel cover



For air-tight installation, fit a suitable air-tight sleeve to the conduit exit side...

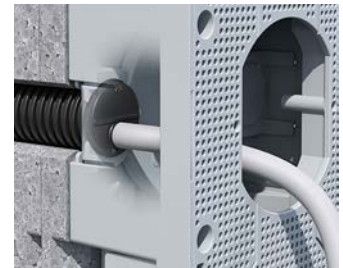

...and fit a sealing plug to the conduit.

Combinations with front panels

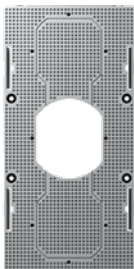

Multi-device front panel (Art. No. 9966.31 and 9966.32); opening \varnothing 1 x 68 mm.

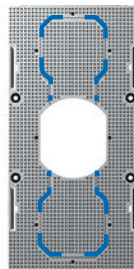

2-way and 3-way combinations can be made by breaking out the covers.

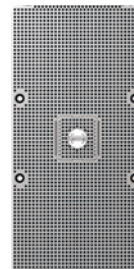

Delivery status (Art. No. 9966.21 and 9966.22), universal mounting plate.

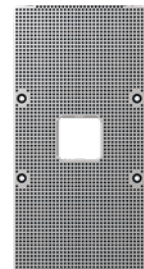

Universal mounting plate with broken-out exit for luminaires.

System equipment carrier 160 – 240 mm



- Adaptation to insulation thickness possible in 10 mm steps
- Including 2 screw dowels
- Material: Polyethylene
- Insulation material: Neopor
- Processing temperature: - 5 °C / + 60 °C



3D animation

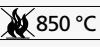

Product-Data

Length x Width x Height	220 x 110 x 160-240 mm	220 x 110 x 160-240 mm
Combination conduit entries M20/25	2	2
Combination	1x1 / 2x1 / 3x1	Luminaire outlet / mounting plate
Screw-in wall-plug	1 x 200 mm, 1 x 240 mm	1 x 200 mm, 1 x 240 mm
Halogen-free	Yes	Yes
 	Yes	Yes / Yes
	-	Yes
Art.-No.	9966.31	9966.21
Inner packaging/shipping	- / 5	- / 5

System equipment carrier 240 – 310 mm



- Adaptation to insulation thickness possible in 10 mm steps
- Including 2 screw dowels
- Material: Polyethylene
- Insulation material: Neopor
- Processing temperature: - 5 °C / + 60 °C



3D animation

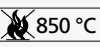

Product-Data

Length x Width x Height	220 x 110 x 240-310 mm	220 x 110 x 240-310 mm
Combination conduit entries M20/25	2	2
Combination	1x1 / 2x1 / 3x1	Luminaire outlet / mounting plate
Screw-in wall-plug	1 x 280 mm, 1 x 320 mm	1 x 280 mm, 1 x 320 mm
Halogen-free	Yes	Yes
 	Yes	Yes / Yes
	-	Yes
Art.-No.	9966.32	9966.22
Inner packaging/shipping	- / 5	- / 5



Installation housing ThermoX® Iso +

Installation housing for the secure and heat-bridge-free installation of rigid and swivelling built-in LED luminaires or other installation accessories in insulated ceilings. The housing protects the surrounding insulation material against the high operating temperatures of the LED luminaire and protects the LED luminaire itself against dirt. The integrated insulation element reliably prevents heat bridges.

- For the installation of luminaires and installation accessories in insulated ceilings
- Suitable for all standard insulation materials
- Thermally-protected installation space
- The integrated insulation element prevents heat bridges
- For insulation thicknesses from 100 mm to 160 mm (170 mm to 350 mm with extension element)
- Adjustment to the insulation thickness in 10 mm steps.
- Installation diameter up to \varnothing 86 mm



Awarded with the
BAKA-Award 2019



Examples of use

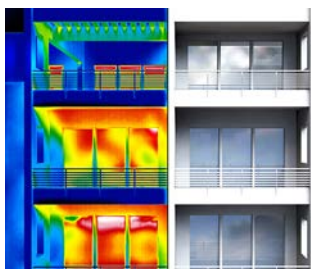

Buildings are constructed heat-bridge-free using the ETICS composite thermal insulation systems, e.g. ...



...insulated external ceilings of built-over terraces with lighting.



...insulated, recessed entrance areas with lighting.



...insulated facades with outdoor lighting over the entrance and garage door.

Heat-bridge calculation / temperature profile

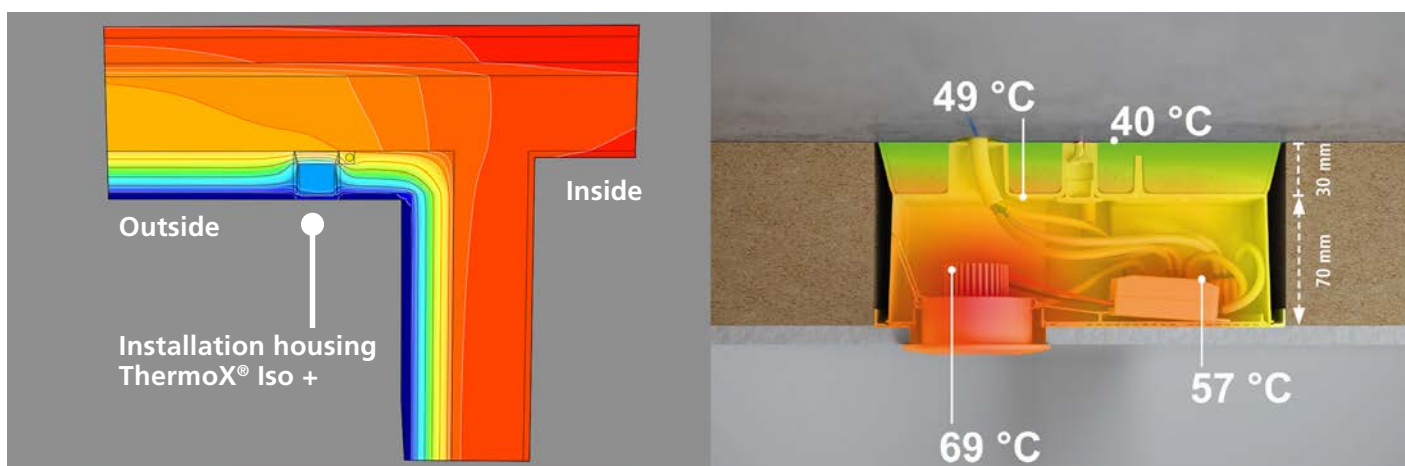

A heat bridge calculation by the Passivhaus Institut, Darmstadt, shows that heat bridges can be reliably prevented by the installation housing for the external insulation. The installation housing is also suitable for use in passive houses.

Installation



Adapt installation housing to the measured insulation thickness.

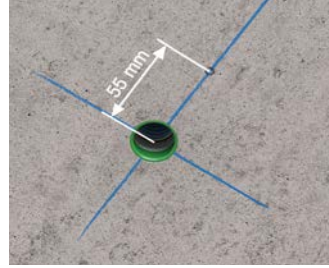

Mark fixing point 55 mm from the luminaire centre point.



Alternative: Position the installation housing with the alignment markings for the luminaire and mark the drill hole.



Break out the conduit entry or cut an exact cable entry for air-tight installation, e.g. by using the KAISER universal opening cutter (Art. No. 1085-80).



Screw installation housing to the ceiling and fit the screw covering.



Insert the conduit or cable into the installation housing; fit sealing plug to the conduit.



Ceiling exit \varnothing 68 mm for knocking in, ceiling outlet up to \varnothing 86 mm for cutting out.



Applying insulation and plaster. Fitting the LED installation spotlight with plenty of space for the ballast device.

Processing instructions



Universal front part for installation diameter of \varnothing 68 mm for knocking in or universal up to \varnothing 86 mm for cutting out (turn by 180°).



Installation depth 70 mm (insulation thickness 100 mm).

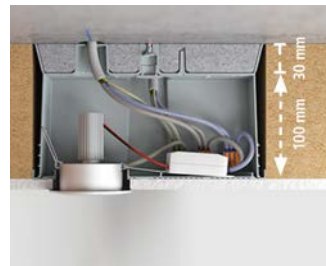

Installation depth 100 mm (insulation thickness 130 mm).

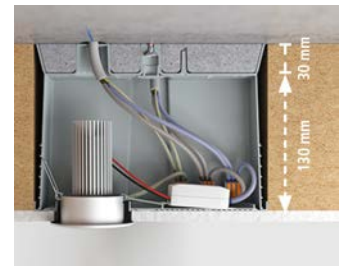

Installation depth 130 mm (insulation thickness 160 mm).

Installation housing ThermoX® Iso +

- with external insulation of ceilings
- for insulation thicknesses of 100 mm and above
- Adjustment to the insulation thickness in 10 mm steps.
- for LED luminaires up to 8 Watt
- max. luminaire installation depth 70 mm to 130 mm (insulation thickness less 30 mm)
- Front panel with ceiling exit (CE) Ø 68 mm or universal up to Ø 86 mm
- Space for ballast devices 120 mm x 30 mm x 28 mm (installation diameter 68 mm, installation depth 70 mm)



3D animation



Product-Data

Length x Width x Height	220 x 110 x 160 mm
Insulation thickness	100 - 160 mm
Ceiling exit (CE) Ø	68 - 86 mm
max. lamp output	8 Watt
max. installation depth for the LED luminaires	70 - 130 mm
Cable or conduit entries up to max. ø 25 mm	5
Halogen-free	Yes
Art.-No.	1159-70
Inner packaging/shipping	- / 6

Extension element

- for installation housing for external insulation
- for insulation thicknesses 170 - 350 mm
- Adjustment to the insulation thickness in 10 mm steps.



Length x Width x Height	220 x 110 x 190 mm
Insulation thickness in combination with Art. No. 1159-70	170 - 350 mm
Halogen-free	Yes
Art.-No.	1159-71
Inner packaging/shipping	- / 6

Telescope equipment carrier and switch box

For the safe installation of luminaires, motion detectors and many other accessories in and on insulated facades. Optimised for the latest insulation thicknesses, the telescopic products permit a wide range of applications in external faces with insulation thicknesses from 80 to 200 mm. The two conduit entries on the basic carrier guarantee secure conduit connection. The cable routing which is integrated in the carrier arm ensures a fast, easy cable pull-in.

- Stable fit to walls and ceilings
- For insulation thicknesses from 80 to 200 mm
- Equipment carriers for accessories up to max. 5 kg
- One-gang boxes can be combined with a standardised 71 mm combination distance
- Conduit entries on the carrier with internal cable routing
- Integrated indicated dimension allows easy cutting off to insulation thickness
- Front fixing and depth stop prevent incorrect installation
- Front fixing of the mounting plate/one-gang box

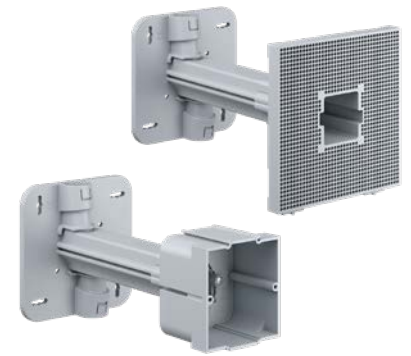

FLUSH-MOUNTING

CAVITY WALL

CONCRETE

HOUSINGS

Examples of use



FIRE PROTECTION

PLUGGABLE

Heat bridge calculation / weight-bearing load

A heat bridge analysis produced by the Passivhaus Institut Dr. Feist, Darmstadt, showed that heat conductivity is only changed to a negligible extent and consequently it is demonstrated that no heat bridges result. When the space between the basic carrier and mounting plate / one-gang box is filled with insulating material, the loss coefficient „x WB“ for the telescope equipment carrier is 0.0085 W/K, and 0.0077 W/K for the telescope switch box.

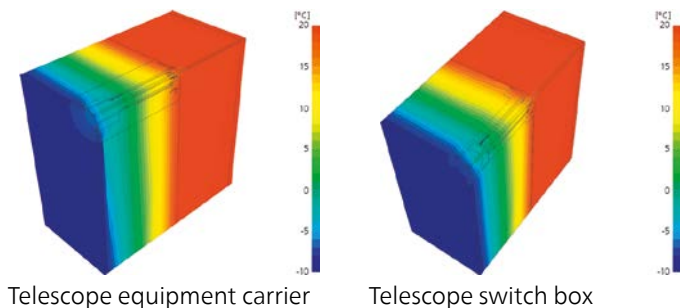

When fitting an equipment carrier to a wall, ensure that the cable entries are positioned vertically.



CONNECTIVITY

CABLE GLANDS

TOOLS

SERVICE

Installing the basic carrier



Prepare the cable routes. Try to avoid direct cable routing through masonry and insulation.



The internal cable routing can easily be broken off to permit cable routing from the rear.



Saw the carrier to the required length. The integrated dimension ensures exact reading of the dimension.



Slotted holes allow precise alignment even when the drill holes are not exact.

Installing the equipment carrier



Push the one-gang box onto the supporting arm as far as the stop.



The front fixing and the depth stop always ensure exact fitting and prevent incorrect installation.

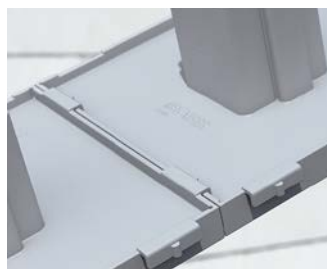

Side fixings allow the secure positioning of several equipment carriers next to each other...



...and stable installation for accessories when the attachment points are far apart.

Installing the one-gang box



Push the one-gang box onto the supporting arm as far as the stop.



The front fixing and the depth stop always ensure exact fitting and prevent incorrect installation.



For multiple combinations, cut out the side separator walls and connect the one-gang boxes.



For multiple combinations, cut out the side separator walls and connect the one-gang boxes.

Product advantages



Dimensions shown on the carrier ensure that the carrier length can easily be sawn off to match the insulation thickness – no need for measuring!



Slotted holes allow precise alignment even when the drill holes are not exact.



The two conduit entries on the carrier guarantee secure conduit support. The integrated cable routing ensures fast, easy cable insertion.



Luminaires and many other accessories are easily fitted in the mounting plate through the plaster using screws up to 4 mm Ø.

Telescope equipment carrier

- for secure installation of luminaires and much more
- for use with external insulation of walls and ceilings
- installation area for dowel-free installation of accessories

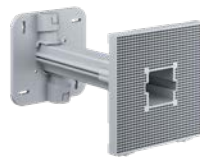

3D animation



Product-Data

Length x Width	120 x 120 mm
Insulation thickness	80 - 200 mm
max. attachment surface for devices	120 x 120 mm
Conduit entry M20 on the carrier	2
Weight when attached to ceiling	5 kg
Weight when attached to wall	5 kg
Halogen-free	Yes
Art.-No.	1159-60
Inner packaging/shipping	- / 10

Telescope switch box

- for secure fixing of sockets and much more
- for use with external insulation of walls and ceilings
- with 2 screw domes
- Standardised combination distance 71 mm



Combination one-gang box

- for combinations with telescope switch box (Art. No. 1159-61)



Depth x Length x Width	50 x 68 x 70 mm	50 x 68 x 70 mm
Insulation thickness	80 - 200 mm	-
Screw spacing	60 mm	-
Conduit entry M20 on the carrier	2	-
Cable entries up to Ø 16 mm	2	2
Halogen-free	Yes	Yes
Art.-No.	1159-61	1159-62
Inner packaging/shipping	- / 10	- / 10



Mini equipment carrier

Mini equipment carrier for later attachment of a variety of accessories to insulated and already plastered composite thermal insulation systems (ETICS). Luminaires, motion detectors, external sensors etc. can be permanently attached easily, quickly, securely and without creating heat bridges.

- For retrofitting in insulated facades
- Exact flush aligning of attachment devices
- Guarantees installation without heat bridges
- 4 swivels for secure anchoring
- No moisture penetration



Examples of use



The small mini device carriers are concealed by luminaires and smaller accessories.



Secure attachment of motion detectors.



Invisible even when close to edges.



Secure, easy fitting of the corner mounting.

Heat bridge calculation

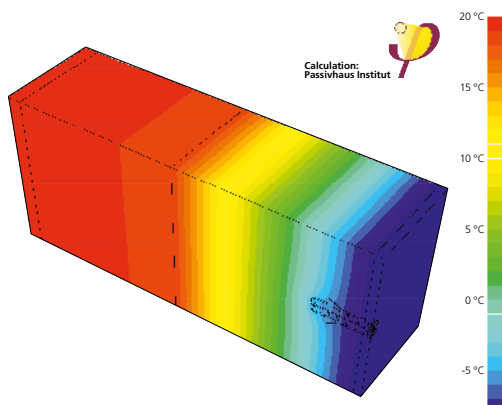

A heat bridge analysis produced by the Passivhaus Institut Dr. Feist, Darmstadt, showed that heat conductivity is only changed to a negligible extent and consequently it is demonstrated that there are no heat bridges in the electrical installation. The loss coefficient „x WB“ is 0.000054 W/K.

Maximum pull-out force for the mini equipment carrier.

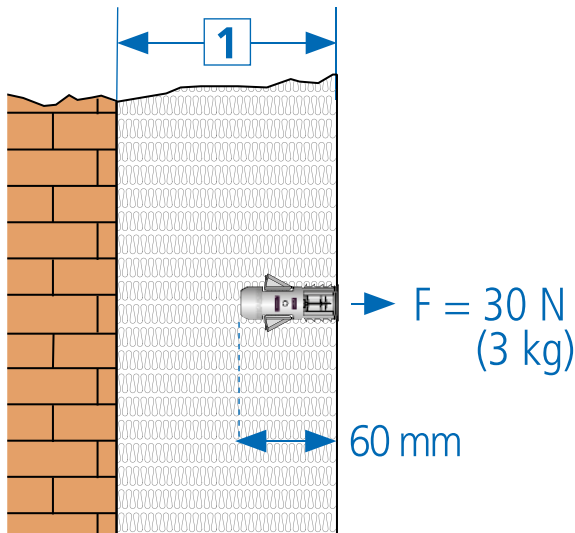

1 External insulation - insulation thickness

Structure of an organic ETICS

The mini equipment carrier was developed especially for later installation in organic composite thermal insulation systems (ETICS).

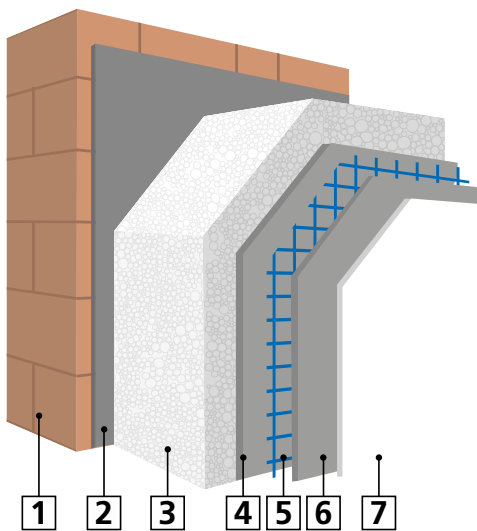

1 Masonry wall | 2 Adhesive | 3 Insulating board | 4 Reinforcement plaster | 5 Reinforcement fabric | 6 Reinforcement plaster | 7 Finish coat of plaster, decorative plaster

Technical information



The swivels anchor the KAISER mini equipment carrier in the insulation.

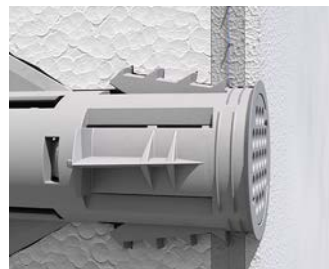

Clamping ribs, sealing lip and holding ring provide additional stability.



The adjustable screw-on surface accommodates a tolerance of up to 10 mm.



The screw-on surface is concealed even when the attachment points are close to the edge.

Installation

The two-piece mini equipment carrier can be anchored securely in the insulated external facade in a few simple steps.

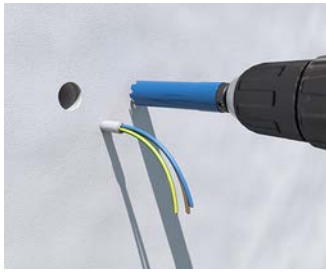

Create installation openings of Ø 20 mm with SPECIAL cutter with depth stop (Art. No. 1088-06).



Release the cutter head and remove the drilled core.



Press the anchor sleeve of the mini equipment carrier into the installation opening so that it is flush with the wall.



Press in the attachment core until it locks into the anchor sleeve.



Pressing in the attachment core anchors the swivels in the insulation material and provides a secure fit for the mini equipment carrier.

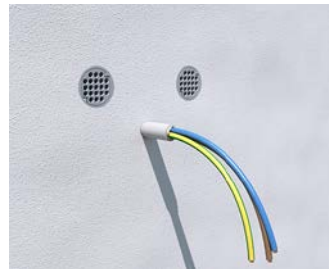

The mini equipment carriers now provide stable and wall-flush screw-on surfaces...



...and provide a tolerance compensation of up to 10 mm. This permits later exact alignment of all installation accessories.



The luminaire is securely and permanently flush-mounted to the wall.

Mini equipment carrier

- Retrofitting in existing composite thermal insulation systems (ETICS)
- consisting of anchor sleeve and attachment core
- for insulation thicknesses of 80 mm and upwards
- Screw-on surface with 10 mm tolerance compensation
- 4 swivel cutters
- 2 ribs
- Sealing lip on all sides
- Weight loading up to 30 N (3 kg)
- equipment attached with self-tapping screws with Ø of 3.2 - 4 mm



3D animation



Product-Data

Length	60 mm
Installation opening	Ø 20 mm
Halogen-free	Yes
Art.-No.	1159-50
Inner packaging/shipping	10 / 100

One-gang junction box ECON® Styro55

One-gang junction box ECON® Styro55 for later attachment of a wide range of installation accessories to insulated and pre-plastered composite thermal insulation systems (ETICS). Switches, sockets, intercoms etc. can be permanently attached easily, quickly, securely and without heat bridges.

- For retrofitting in insulated facades
- Cutter system prevents damage to cables
- Guarantees installation without heat bridges
- 4 swivels for secure anchoring
- No moisture penetration



Examples of use



Secure attachment to a ETICS without adhesive.



Accessory installation without disrupting the insulation or creating heat bridges.



Secure and flush-mounting installation including multiple combinations.

Heat bridge calculation

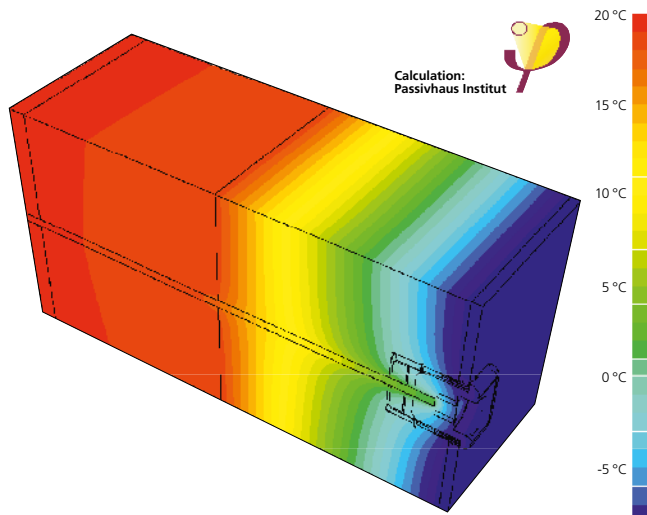

A heat bridge analysis produced by the Passivhaus Institut Dr. Feist, Darmstadt, showed that heat conductivity is only changed to a negligible extent and consequently it is demonstrated that no heat bridges result. The loss coefficient „x WB“ is 0.005044 W/K.

Technical information



Tool-free and wind-tight cable entry prevents air draughts along the cable.



The swivels anchor the box securely in the insulation material. The ribs at the front also give the box additional support.



The lip at the back forms a sealing barrier to the insulation material and prevents air draughts along the box.



The all-round sealing lip seals the ETICS, so no moisture can penetrate.

Installation with an existing cable



Ensure that the cable was fed through the insulation material panel. Shorten the existing cable to approximately 10 cm.

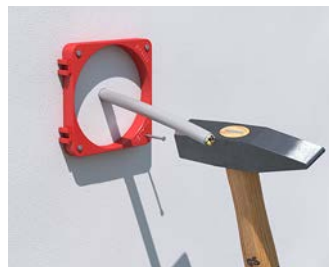

Fasten the KAISER centering aid Ø 68 mm (Art. No. 1090-68) to the composite thermal insulation system using steel nails.



Using SPECIAL cutter (Art. No. 1088-07), cut the installation opening precisely as far as the depth stop.



Remove the drilled core from the opening.



The opening is now only as deep as necessary. The insulation remains intact and the cable is undamaged.



The ECON® technology elastic sealing membrane ensures a wind-tight seal around the cable as it is pushed through.



Simply insert the ECON® Styro55 one-gang junction box in the installation opening.



Press the box in the holding ring until the rim is flush with the wall.



Use KAISER tool (Art. No. 1090-22) to position the four swivels in the catch mechanism.



Flush-mounting and secure fit of the one-gang box.



Using the KAISER stripping pliers, (Art. No. 1190-02), remove the insulation from the cable.



The swivel sheaths on the box seat themselves securely in the insulation material.

Installation of combinations



Using the combined cutting aids (Art. No. 1090-68), cut installation openings at the standard spacing of 71 mm.



Before inserting the support connector, remove the strap without using a tool.

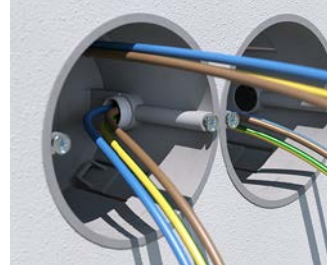

Fully-insulated through-wiring is accomplished using the KAISER support connector (Art. No. 9060-88).



Secure and permanent attachment of multi-gang combinations, intercoms and much more.

One-gang junction box ECON® Styro 55

- Retrofitting in existing composite thermal insulation systems (ETICS)
- for insulation thicknesses of 80 mm and upwards
- 4 swivel cutters
- Clamping ribs
- Sealing lip on all sides
- including setting tool (Art. No.1090-22) per packaging unit



3D animation



Product-Data

Depth	60 mm
Cut hole Ø	68 mm
Cable entries up to Ø 15 mm	2
Device screws	2
Screw spacing	60 mm
Support connectors for each package	5
	Yes
Art.-No.	1555-51
Inner packaging/shipping	10 / 100



One-gang junction box - ECON® Iso +

The ECON® Iso + one-gang junction box is the solution for electrical installation work in wood fibre insulation boards. Four swivels, specially designed for use in solid heat insulation and plaster base boards, ensure secure anchoring – also for retrofitting! The ECON® technology elastic sealing membrane guarantees air tightness and allows the toolless insertion of conduits or cables. This means that switches, sockets, intercoms and many more can be installed permanently and securely and heat bridge-free.

3 times awarded in 2019:

B+B Bauen im Bestand
Produkt des Jahres 2019
Sieger in der Kategorie Energetische Sanierung



- Air-tight and heat bridge-free electrical installation in accordance with DIN 18015-5
- Suitable for pressure-resistant insulation panels of 60 mm thickness and greater
- 4 swivels for secure mechanical anchoring
- Making of combinations is possible

Examples of use

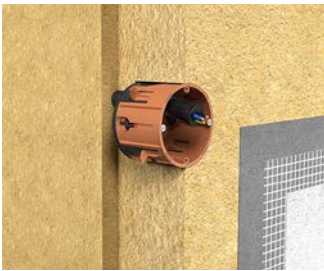

Ecological wall insulation in old and new buildings in both wood and solid constructions.



Suitable for mounting in pressure-resistant wood fibre insulation boards with a medium gross density of 110 - 180 kg/m³.

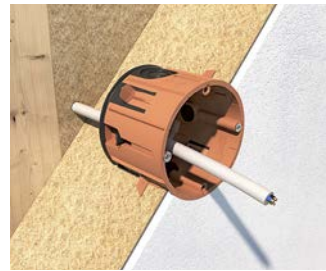

Retrofitting is possible. For retrofitting on the plastered wall, fit the box without a mounting frame.



User-friendly mounting of the installation of accessories - also in combination - possible.

Processing instructions



Mounting in an unplastered insulation panel – use a mounting frame.

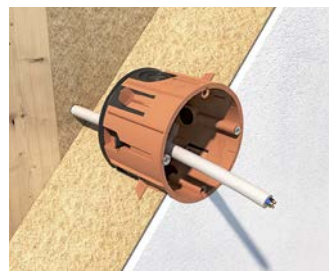

Mounting in a plastered insulation panel is possible, even with an existing cable.



The membrane which seals the swivel guarantees air-tightness.



Plenty of entry options using ECON® technology for conduits and cables.

Mounting on unplastered insulation panel

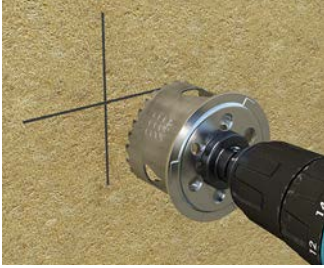

Cut the Ø 68 mm installation opening using a suitable cutter (e. g. Art. No. 1082-30; countersink hole cutter and ejector spring must be removed).

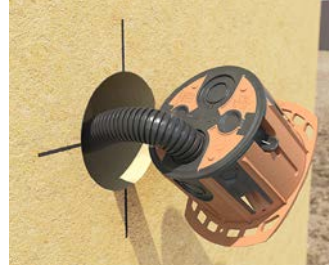

Fit mounting frame, then feed the cable or conduit through the airtight membrane and into the box.

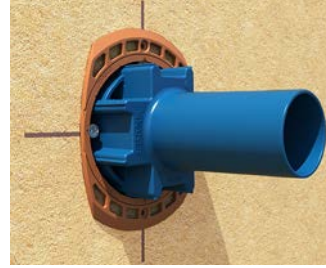

Using gentle pressure, insert the setting tool (Art. No. 1090-22) into the box as far as the stop. The swivels much expand completely.

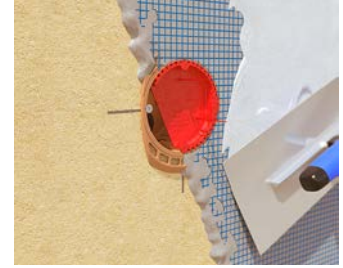

Before plastering, fit the signal cover (Art. No. 1181-60). Protects the interior of the box, the screw domes and the screw heads.

Mounting on plastered insulation panel in a combination



Using SPECIAL cutter (Art. No. 1088-07) and two centering aids (Art. No. 1090-68), cut two installation openings at least 55 mm deep and with a diameter of 68 mm.



The ECON® technology sealing membrane wraps itself air-tight round the cable during insertion.



Through-wiring takes place after removal of the opening tabs and fitting of the support connector.



Installation of various installation accessories is possible – including in combinations.

One-gang junction box - ECON® Iso +

- Sealing lip on all sides
- 4 swivel cutters
- 4 screw domes
- with 2 device screws +/-
- including centering aid
- including setting tool (Art. No. 1090-22) per packaging unit



INNOVATION



3D animation



Product-Data

Depth	55 mm
for insulation thicknesses	> 60 mm
Cut hole Ø	68 mm
Device screws	2
Screw spacing	60 mm
Cable entries of up to Ø 11.5 mm	4
Conduit entries M20	4
Support connectors for each package	5
Halogen-free	Yes
	Yes
Art.-No.	1159-55
Inner packaging/shipping	10 / 100

International products



For international projects, we offer a large range of products which meet the relevant national standards and regulations.

- Dimensions and approvals based on national standards
- Suitable installation tools
- Many combination options



Q-range® one-gang boxes

- For masonry installation
- With screw domes
- Conduit entries on all sides
- Suitable for 60 / 71 mm combinations
- Protection class IP 2X



Length x Width x Depth	60 x 60 x 50 mm	60 x 60 x 65 mm	60 x 60 x 50 mm	60 x 60 x 65 mm
Fixing screw spacing	60 mm	60 mm	60 mm	60 mm
Device screws	2	2	-	-
Screw domes for device attachment	V: 2 x 3, H: 2 x 1	V: 2 x 3, H: 2 x 1	V: 2 x 3, H: 2 x 1	V: 2 x 3, H: 2 x 1
Horizontal conduit entry	2 x M20, 2 x M16/20 mm	2 x M20, 2 x M16/20 mm	2 x M20, 2 x M16/20 mm	2 x M20, 2 x M16/20 mm
Vertical conduit entry	2 x M16, 4 x M16/20 mm	2 x M16, 4 x M16/20, 4 x M20 mm	2 x M16, 4 x M16/20 mm	2 x M16, 4 x M16/20, 4 x M20 mm
Base conduit entry	2 x M20, 2 x M16, 2 x Ø 10,5 mm	2 x M20, 2 x M16, 2 x Ø 10,5 mm	2 x M20, 2 x M16, 2 x Ø 10,5 mm	2 x M20, 2 x M16, 2 x Ø 10,5 mm
Through-wiring fields	1	2	1	2
Halogen-free	Yes	Yes	Yes	Yes
 CEBEC	Yes	Yes	Yes	Yes
Art.-No.	7500	7650	7501	7651
Inner packaging/shipping	10 / 100	10 / 100	10 / 100	10 / 100

Q-range ECON® one-gang box

- Air-tight design with sealing membranes
- Centre distance 60 mm horizontally as well as 71 mm horizontally and vertically
- 2 x 3 fixed entries, 2 x 2 fixed entries, 4 base entries



Length x Width x Depth	60 x 60 x 50 mm
for screw fixing	Yes
Horizontal conduit entry	2 x 20 + 2 x 16 mm
Base conduit entry	2 x 20 + 2 x 16 mm
Vertical conduit entry	2 x 20 + 1 x 16 mm
Halogen-free	Yes
Art.-No.	752
Inner packaging/shipping	10 / 100

Q-up®

- Plaster compensation frame with 2 screws 40 mm, Pozidriv drive
- For boxes which are placed too deeply



Art.-No.	994
Inner packaging/shipping	10 / 100

Q-signal®

- Protects the box interior, the screw domes and screw heads during plastering
- Reusable



Art.-No.	975
Inner packaging/shipping	10 / 100

One-gang box - Swiss standard

- compatible with Feller SNAPFIX®
- Suitable for screw or claw fixing of accessories
- For device screws Ø 3 mm
- Max. tightening torque 0.5 Nm
- With injection-moulded signal cover
- For assembling combinations, centre distance 60 mm
- Low-lying plaster grips



Depth	59 mm
Diameter	71 mm
Break-out openings Ø 20 mm	11
Combination conduit entries M20/25	1
650 °C /	Yes / Yes
	Yes /
Art.-No.	9921
Inner packaging/shipping	- / 50

One-gang box - Swiss standard



- suitable for screw attachment of equipment
- to create combinations in both axis directions, centre distance 60 mm
- with separator wall



Length x Width x Depth	72 x 72 x 57 mm
Break-out openings Ø 20 mm	13
Combination conduit entries M20/25	5
CE	Yes
Art.-No.	99.1234
Inner packaging/shipping	- / 50

Signal cover

- for one-gang box Art. No. 99.1234



Length x Width	67 x 67 mm
Art.-No.	99.1234.06
Inner packaging/shipping	- / 25

In-wall back boxes, quadratic glow wire tested 850°C



- Flat bearing surface thanks to 4 support points
- Voltage transfer is prevented by countersunk screw mounts
- Essential in timber construction
- Extension frame for sub-ceiling insulation available



Length x Width x Depth	115 x 115 x 76 mm	115 x 115 x 101 mm
Break-out openings Ø 20 mm	16	16
Combination conduit entries M20/25	4	8
850 °C /	Yes / Yes	Yes / Yes
CE	Yes	Yes
Art.-No.	9909.01.850	9908.01.850
Inner packaging/shipping	- / 50	- / 30

Heightening frame for quadratic in-wall back boxes, glow wire tested at 850°C



- For increasing the front-to-back depth of the box or for sub-ceiling insulation
- Multiple extensions possible
- With two fixing screws

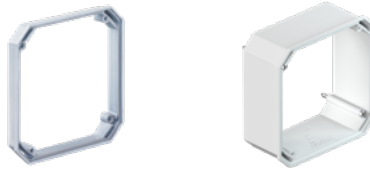

Length x Width x Depth	115 x 115 x 13 mm	115 x 115 x 45 mm
850 °C /	Yes / Yes	Yes / Yes
CE	Yes	Yes
Art.-No.	9908.68	9908.68.45
Inner packaging/shipping	- / 10	- / 10

One-gang box (Italian and American standard)

- with 2 screw domes (without screws)



Length x Width x Depth	100 x 60 x 52 mm	121 x 60 x 52 mm
Screw spacing	83 mm	108 mm
M16 conduit entries	1	1
Conduit entries M20	12	12
Conduit entries M25	3	6
Art.-No.	662	663
Inner packaging/shipping	5 / 100	5 / 100

One-gang box acc. to EN 60670 and ÖVE

- variable screw fitting 57-63 mm
- 4 expanding claw fields



Depth	51 mm
Cable entries 1 x 5 x 1.5 mm ² or 3 x 2.5 mm ²	Yes
Conduit entries M16-M20	10
Telephone cable J-Y(ST)Y	1
	Yes
Art.-No.	1076-20
Inner packaging/shipping	- / 100

Cavity wall installation



Cavity wall basis installation

- Complete system for all cavity wall applications
- FX quick-assembly technology FX⁴ for time-saving installation
- Universal installation housing with mineral fibreboard for all common unit sizes (e.g. displays, LED luminaires, etc.)
- Halogen-free product range



Air-tight cavity wall installation

- Air-tight installation as per GEG
- ECON[®] technology for air-tight, toolless cable and conduit entries
- Air-tight sleeves for the air-tight feed-through of cables and conduits
- ECON[®] Fix: rib fastening in different wall material combinations without lugs
- ECON[®] Data for the connection and installation of data and network cables



Special cavity wall solutions









- HWD fire-protection boxes for **fire-protection walls** and ceilings, as well as shipbuilding walls
- Safe, visible and certified protection without filling and lubrication through the use of KAISER bulkhead systems for cables and conduits
- Sound insulation boxes for insertion into **sound insulation walls**
- Radiation protection one-gang boxes for insertion into leaded and lead-free **radiation-protection walls**
- Clean room boxes for use in clean rooms in a medical environment or in hygienic areas
- Damp room boxes for professional installation in sealed interior rooms
- International products for accessory installation according to national standards



see chapter **TOOLS**
from page 376

Tools

- Professional system tools for fast, safe installation
- Extensive system accessories

	Basis installation 	Air-tight 	Clean room 	Sound insulation 	Radiation protection 	Shielded Environmentally-friendly construction 	Damp room 	Solid wood 	Fire protection 
For installation accessories									see chapter FIRE PROTECTION
One-gang boxes	pg. 88	pg. 99	-	-	-	-	-	-	pg. 285
One-gang junction boxes	pg. 88	pg. 99	pg. 137	pg. 131	pg. 138	pg. 142	pg. 145	-	pg. 285
One gang boxes for thin boarding	pg. 91	-	-	-	-	-	-	-	-
One-gang junction boxes for thin boarding	pg. 92	-	-	-	-	-	-	-	-
One-gang junction boxes for solid wood	pg. 113	pg. 107	-	-	-	-	-	pg. 119	pg. 287
Two-gang junction boxes	pg. 89	-	-	-	-	-	-	-	-
Electronics boxes	pg. 93/114	pg. 93/114/109/110	-	pg. 132/135	-	-	-	-	pg. 283
Perilex one-gang boxes	pg. 90	-	-	-	-	-	-	-	-
CEE one-gang boxes	pg. 90	pg. 113	-	-	-	-	-	-	-
Universal installation housings	pg. 151	-	-	-	-	-	-	-	-
Versions									
available halogen-free	•	•	-	•	•	-	-	-	•
For cable outlets									
Wall light connection boxes	pg. 94	pg. 94/114	-	-	-	-	-	-	-
Luminaire connection boxes	pg. 95	-	-	-	-	-	-	-	-
For cable entries									
Sealing sleeves	-	pg. 122	-	-	-	-	-	-	-
Sealings	-	-	-	-	-	-	-	-	-
For cable connections									
Junction boxes	pg. 90 / 148	-	-	-	-	-	-	-	-
Junction casings	pg. 147	-	-	-	-	pg. 43/143	-	-	-
Potential equalisation casing	pg. 149	-	-	-	-	-	-	-	-
Accessories									
Fixing	pg. 146	pg. 146	pg. 146	pg. 146	-	pg. 146	pg. 146	pg. 146	pg. 146
Subsequent sealing (air-tight)	pg. 31/116	-	-	-	-	-	-	-	-
Sealing of electrical installation conduits (air-tight and smokeproof)	-	pg. 33/117/302	-	-	-	-	-	pg. 33/117/302	pg. 33/117/302
Plaster compensation	pg. 96	pg. 96	-	-	-	-	-	-	-
Support connector	pg. 96/114	pg. 96/114	-	pg. 57/131/141	pg. 139	-	-	pg. 57/131/141	pg. 285
End cover	pg. 149	pg. 149	-	pg. 41/131	-	pg. 43/143	-	-	pg. 289

FLUSH-MOUNTING

CAVITY WALL

CONCRETE

HOUSINGS

FIRE PROTECTION

PLUGGABLE

CONNECTIVITY

CABLE GLANDS

TOOLS

SERVICE



Plus-minus device screw

The screw allows the installer to fit screws and devices screws with the same screwdriver. In addition, the new screw drive can be used with many other components, e. g. switches, sockets, terminal blocks etc. Optimal shape for +/- or PZ1 screwdrivers, and at the same time a slot screwdriver up to max. 4mm width can be used. A closed long-slot ensures that the blade does not slip out.

Processing instructions



Device screw with extra-flat countersunk head for low installation height.



Combination drive Pozidriv1/ slot provides the best grip.

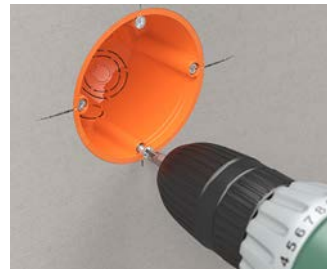

Suitable for fitting using cordless screwdriver.



Optimal for fitting with +/- screwdriver.



FX⁴ technology - the fastest means of screw attachment

FX⁴ technology provides the fastest-ever screw fixing for cavity wall boxes and installation housings. The special thread shape enables up to 40% quicker mounting with simultaneous high self-locking effect.

- 40% quicker mounting
- High self-locking effect
- In cavity wall boxes and installation housings

Processing instructions

The screws with the steep thread design and the 3-part thread reduce installation time by up to 40%.



Standard screw.



KAISER standard.



Example of use for universal housing.



Example of use of EnoX®.

Cavity wall installation boxes

The new KAISER cavity wall installation boxes with proven mounting lug technology and improved product features. A practical design and a large selection of cable and conduit entries allow a large number of applications. Additional boxes for installation in thinly boarded walls or solid wood walls complete the wide range. VDE certification documents the high level of quality.

- Screws ensure permanent fixing
- Entries can be broken out for cables and conduits
- Combinable and through-wiring by using support connectors
- Fixing of devices by means of pre-mounted device screws



Processing instructions

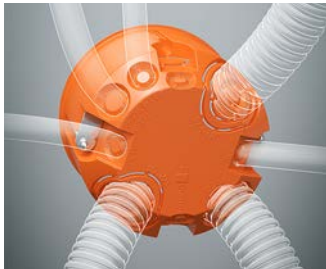

New boxes provide a large number of entry options.



Marking of the openings simplifies the assignment of the correct diameter.



Combination entry for cable and conduits up to max. Ø 25 mm.



Specific openings can be made simply by breaking out.

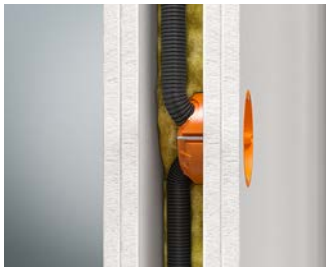

Bending of the conduit up to 90° is easily possible in the case of slim wall constructions or in the installation level.



Cable and conduit retention prevents slipping-out of live parts.



Standardised round support connector for fast installation.

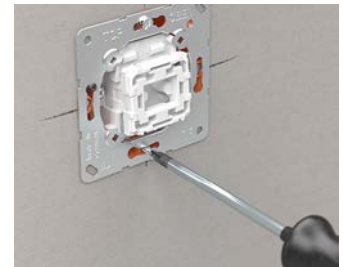

Easy-to-fit device fixing thanks to new +/- screw.

Technical processing instructions / Standards

- in accordance with DIN EN 60670
- Standardised combination distance 71 mm
- fully-insulated through-wiring in combinations of one-gang boxes and one-gang junction boxes for switches and sockets possible
- with holding ring
- break-out openings for sheathed cabling, low-voltage wires and DIN EN conduits
- integrated retention of NYM cables in accordance with DIN 60670/DIN 49073, self-locking of the conduits
- can also be used as junction box in accordance with DIN EN 60670

One-gang boxes, one-gang junction boxes, accessories

for cavity wall installation

O-range® one-gang box

· with holding ring



3D animation

Depth	49 mm	49 mm
For panel thickness	7 - 40 mm	7 - 40 mm
Cut hole Ø	68 mm	68 mm
Device screws +/-	2	2
Ø 20 / 25 mm combination entries	2	2
Cable entries 3 x 2.5 mm ² or 5 x 1.5 mm ²	2	2
Cable entries 3 x 1.5 mm ²	2	2
Cable entries for low voltages	2	2
Support connectors for each package	7	7
Halogen-free	-	Yes
 / 	Yes / Yes	Yes / Yes
Art.-No.	9063-02	9063-78
Inner packaging/shipping	25 / 250	25 / 250



Accessories: Support connector, air tight, Page 96/114

O-range® one-gang junction box

· with holding ring



3D animation

Depth	62 mm	62 mm
For panel thickness	7 - 40 mm	7 - 40 mm
Cut hole Ø	68 mm	68 mm
Device screws +/-	2	2
Conduit entries Ø 20 mm	1	1
Ø 20 / 25 mm combination entries	2	2
Cable entries 3 x 2.5 mm ² or 5 x 1.5 mm ²	3	3
Cable entries 5 x 2.5 mm ² or 7 x 1.5 mm ²	1	1
Cable entries 3 x 1.5 mm ²	3	3
Cable entries for low voltages	2	2
Support connectors for each package	7	7
Halogen-free	-	Yes
 / 	Yes / Yes	Yes / Yes
Art.-No.	9064-02	9064-78
Inner packaging/shipping	25 / 250	25 / 250

Accessories: Support connector, air tight, Page 96/114

One-gang box

- with holding ring





Depth	35 mm	35 mm
Cut hole Ø	68 mm	68 mm
For panel thickness	7 - 28 mm	7 - 28 mm
Device screws +/-	2	2
Cable entries 3 x 1.5 mm ²	4	4
Halogen-free	-	Yes
Art.-No.	9061-00	9061-77
Inner packaging/shipping	25 / 250	25 / 250

Two-gang junction box

- for 2 electrical inserts or 1 block insert
- with cover (Art. No. 9062-90), for use as a junction box
- use separator wall to separate electrical circuits Art. No. 9062-22
- with holding ring



Depth	47 mm	47 mm
For panel thickness	7 - 40 mm	7 - 40 mm
Cut hole Ø	2 x 68 mm	2 x 68 mm
Device screws +/-	4	4
Centre distance	71 mm	71 mm
Conduit entries Ø 20 mm	6	6
Cable entries 3 x 2.5 mm ² or 5 x 1.5 mm ²	2	2
Cable entries 3 x 1.5 mm ²	4	4
Halogen-free	-	Yes
 / 	Yes / Yes	Yes
Art.-No.	9062-02	9062-77
Inner packaging/shipping	10 / 100	10 / 100

Accessories: Support connector, air tight, Page 96/114 ; Connecting clip for stacking boxes 9062-02/-77, Page 94

Replacement cover

- for junction box Art. No. 9062-02



Length x Width	145 x 75 mm
Art.-No.	9062-90
Inner packaging/shipping	10 / -

One-gang boxes, one-gang junction boxes, accessories

for cavity wall installation

PERILEX® /CEE One-gang box

- with holding ring
- for device inserts 16 A



Depth	50 mm	50 mm	50 mm	50 mm
For panel thickness	12,5 - 40 mm	12,5 - 40 mm	12,5 - 40 mm	12,5 - 40 mm
Cut hole Ø	74 mm	74 mm	74 mm	74 mm
Screw spacing	67 mm	67 mm	67 mm	67 mm
with 2 countersunk device screws 4 mm Ø, 16 mm in length to facilitate use of 16 A PERILEX inserts	Yes	Yes	-	-
Halogen-free	-	Yes	-	Yes
With sealing ring for protection class IP 34 and 2 raised head 4 mm Ø device screws, length 20 mm, for use with 16 A CEE equipment inserts	-	-	Yes	Yes
 / 	Yes / Yes	Yes	Yes	Yes
Art.-No.	9067-01	9067-77	9075-01	9075-77
Inner packaging/shipping	10 / 100	10 / 100	10 / 100	10 / 100

Junction box

- with universal VDE cover Art. No. 1184-90
- with holding ring
- with 2 Ø 4 x 16 mm countersunk head screws



Depth	50 mm	50 mm
For panel thickness	12,5 - 40 mm	12,5 - 40 mm
Cut hole Ø	74 mm	74 mm
Screw spacing	67 mm	67 mm
Halogen-free	-	Yes
	Yes	Yes
Art.-No.	9071-01	9071-77
Inner packaging/shipping	10 / 100	10 / 100

O-range® one-gang box for thin boardings

A new one-gang box is now available in the O-range® programme for walls with thin boarding or small cavity: thanks to its installation depth of just 35 mm and the zero clamping technology, which ensures a permanently firm hold, it is particularly suitable for walls with little space or thin wall thickness.

- With zero tension technology for thin boarding
- Low installation depth of 35 mm
- Cable entries with integrated cable retention
- Device screws with flat countersunk head
- For cables up to Ø 11.5 mm



Application examples

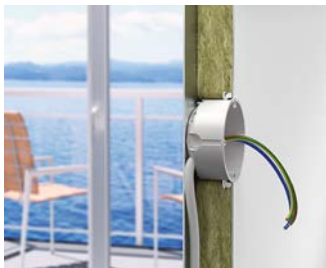

The box is particularly suitable for walls with limited space or thin wall thickness.



In addition, the use in container...



...or shipbuilding possible.



The special zero clamping technology for a clamping range of 0.2 to 30 mm ensures a permanently firm hold.

O-range® one-gang box for thin boardings

- for walls with a small cavity from 35 mm
- for thin boarding
- can be combined with each other



Depth	35 mm	35 mm
For panel thickness	0,2 - 30 mm	0,2 - 30 mm
Cut hole Ø	68 mm	68 mm
Device screws +/-	2	2
Cable entries Ø 4 up to 11.5 mm	6	6
Support connectors for each package	5	5
Halogen-free	-	Yes
	Yes	Yes
Art.-No.	9061-01	9061-78
Inner packaging/shipping	25 / 250	25 / 250

One-gang boxes, one-gang junction boxes, accessories for cavity wall installation

One-gang box for thin boardings

- for boardings that do not permit any countersinking
- with thin holding ring
- Protection class IP 3X





Depth	41 mm	41 mm
For panel thickness	0,2 - 40 mm	0,2 - 40 mm
Cut hole Ø	68 mm	68 mm
Device screws	2	2
Conduit entries Ø 20 mm	2	2
Cable entries 3 x 1.5 mm ²	4	4
Halogen-free	-	Yes
	Yes	Yes
Art.-No.	9068-04	9068-74
Inner packaging/shipping	25 / 250	25 / 250

One-gang junction box for thin boardings

- for boarding that does not permit countersinking (e.g. metal-covered boarding)
- with thin holding ring



Depth	61 mm	61 mm
For panel thickness	0,2 - 40 mm	0,2 - 40 mm
Cut hole Ø	68 mm	68 mm
Device screws	2	2
Conduit entries Ø 20 mm	4	4
Cable entries 3 x 1.5 mm ²	4	4
Cable entries 3 x 2.5 mm ² or 5 x 1.5 mm ²	2	2
Cable entries for low voltages	2	2
Halogen-free	-	Yes
 / 	Yes / Yes	Yes / Yes
Art.-No.	9068-03	9068-76
Inner packaging/shipping	25 / 250	25 / 250

Electronics box

Cavity wall electronics box for switching units, electronic components, cables and terminals in cavity walls. The box can be subdivided and combined, so it offers a wide range of usage options.

- For different voltage types by using the associated separator wall
- Integrating radio or EIB actuators
- With a cover that can be wallpapered and filled
- Can be combined with each other as well as with one-gang boxes and one-gang junction boxes



Application examples

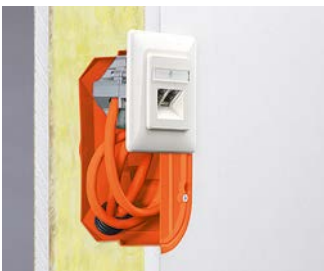

The cover can be fitted flush with the wall for wallpapering over...

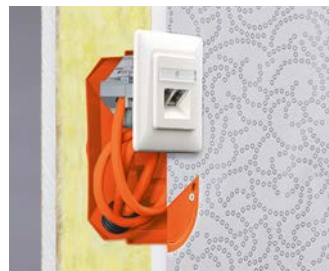

...or turned 180° for filling. This will reduce any possible switching sounds.



Network connection boxes can be used while maintaining the cable bending radii and with the best possible data transfer speeds.



The electronics box offers a generous installation space for the decentralised installation of small window actuators for controlling blinds and heating, for example.

Electronics box

- air-tight version with additional sealing lip
- Tunnel twin-chamber box with enclosed separator wall and cover that can be wallpapered over.
- for accessory inserts and electronic components, such as EIB actuators, communication technology, radio control elements, alarm modules, etc.
- with holding ring



Depth	75 mm	75 mm
Centre distance	71 mm	71 mm
Cut hole Ø	2 x 68 mm	2 x 68 mm
Air-tight	Yes	Yes
Halogen-free	-	Yes
	Yes	Yes
Art.-No.	9062-94	9062-74
Inner packaging/shipping	10 / 100	10 / 100

One-gang boxes, one-gang junction boxes, accessories

for cavity wall installation

Connecting clip for stacking boxes

- for horizontal combination of two-gang junction boxes 9062-02 or electronics boxes 9062-94





Art.-No.	9062-50
Inner packaging/shipping	10 / -

Wall light connection box

- with inner fitting cover
- not to be used as a junction box!
- with holding ring



Depth	40 mm	45 mm	45 mm
Cut hole Ø	2 x 35 mm	35 mm	35 mm
For panel thickness	7 - 30 mm	7 - 40 mm	7 - 40 mm
Conduit entries Ø 20 mm	1	-	-
Cable entries 3 x 1.5 mm ²	2	1	1
Centre distance	30 mm	-	-
If necessary use screw cover 1148-90	Yes	-	-
Air-tight	-	Yes	Yes
Halogen-free	-	-	Yes
 / 	Yes / Yes	-	-
Art.-No.	9148-00	9248-01	9248-77
Inner packaging/shipping	25 / 100	25 / 100	25 / 100

Cover

- for wall light connection boxes Art. No. 1048-00 and Art. No. 9148-00
- With Ø 3.2 x 15 mm cover screws



Length x Width	75 x 40 mm
Halogen-free	Yes
Art.-No.	1148-90
Inner packaging/shipping	25 / 250

Luminaire connection box

- with M5 metal thread for light hooks
min. length 55 mm
- maximum load 20 N (2 kg)
- can also be used as ceiling light
junction box
- with holding ring
- Important! Always screw in light hook
fully.



Depth	47 mm
For panel thickness	7 - 40 mm
Cut hole Ø	68 mm
Conduit entries Ø 20 mm	2
Cable entries 3 x 2.5 mm ² or 5 x 1.5 mm ²	2
Cable entries 3 x 1.5 mm ²	2
	Yes
Art.-No.	9063-50
Inner packaging/shipping	- / 10

Hook screw with M5 thread

- Proof voltage: 2500 V tested
- For retrofitting in ceiling boxes (EN
60670)
- with M5 thread, fully insulated



	55 mm	65 mm
Length of shank	55 mm	65 mm
Diameter hook	26 mm	26 mm
Overall length	81 mm	91 mm
Thread length	10 mm	10 mm
Art.-No.	1226-55	1226-65
Inner packaging/shipping	- / 150	- / 150

One-gang boxes, one-gang junction boxes, accessories

for cavity wall installation

Plaster compensation rings

- to compensate for deep-seated boxes
- plaster compensation rings with same diameter can be stacked
- with 2 screws for attaching equipment and 2 ring attachment screws



Height	10 mm	20 mm	12 mm	24 mm
Screw spacing	60 mm	60 mm	67 mm	67 mm
for boxes with an outer Ø	68 mm	68 mm	74 mm	74 mm
Art.-No.	9155-61	9155-62	9155-71	9155-72
Inner packaging/shipping	25 / 250	25 / 250	10 / 100	- / 100

Support connector

- For fully insulated through-wiring in combinations
- to make air-tight combinations
- for Art. Nos. 9066-01/12, 9068-01, 9263-..., 9264-..., 9062-02/-77, 9062-94/-74, 9268-94/-74, 9266-22/-77



Halogen-free	-	Yes
Art.-No.	9060-98	9060-78
Inner packaging/shipping	25 / 100	25 / 100

Support connector

- for through-wiring of combinations to IP 30 standard
- for all boxes with a trapezoidal support connector opening



Halogen-free	-	Yes
Art.-No.	9060-97	9060-77
Inner packaging/shipping	50 / 250	50 / 50

Compensation ring up to max. Ø 71 mm

- for all Ø 68 mm cavity wall boxes
- for oversize drill holes
- can also be used for combinations where the formed surfaces are located next to each other

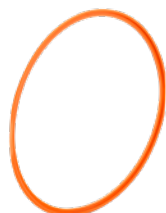

Compensation ring from Ø 74 mm to Ø 68 mm

- for all Ø 68 mm cavity wall boxes
- for oversize drill holes
- can also be used for combinations where the formed surfaces are located next to each other



Compensation up to max. Ø 71 mm	Yes	-
Compensation from Ø 74 mm to Ø 68 mm	-	Yes
Art.-No.	9060-40	9060-42
Inner packaging/shipping	25 / 250	25 / 250

Air-tight cavity wall installation

Air-tight O-range® cavity wall boxes with ECON® technology for energy-efficient electrical installation according to GEG. The elastic ECON® technology sealing membrane allows air-tight electrical installation.

- Elastic sealing membrane for guaranteed air-tightness
- Innovative clamp technology with integrated cable retention
- Toolless cable and conduit entry
- Air-tight combined with support connector



Technical information

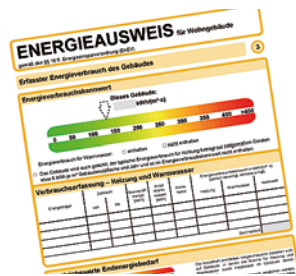

As a key component of the new German Building Energy Saving Ordinance (GEG), the energy performance certificate is a prerequisite for both commercial and residential properties. It creates more transparency for both buyers and tenants regarding the energy efficiency of a property. This factor is set to become more important in the real estate industry, not only for new build projects but also for renovation projects (existing housing).

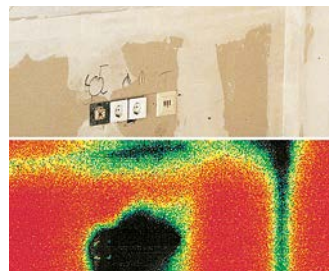

Thermographic photographs highlight the thermal losses, which occur in conventional electrical installations.



With the help of various test procedures such as thermographic photographs, the blower-door-test and thermo anemometer measurements, we and various neutral institutions have proven the level of air tightness achieved by KAISER installation systems.

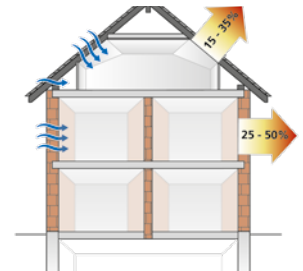

Especially in cavity wall construction, an air-tight building shell, guaranteed largely through the moisture barrier foil, plays an important role in complying with permissible energy values. Each conventional installation opening breaks this air-tight shell and results in uncontrolled artificial currents, which often weaken other energy saving measures significantly.

Average heat energy consumption in houses with a living surface area of 100 m²

House type	"Normal house" (housing)	Low-energy house	Passive house	Zero-heating energy house	Energy-autonomous house (special case)
Fuel oil consumption	approx. 2200 l/year	approx. 850 l/year	approx. 180 l/year	approx. 0 l/year	approx. 0 l/year
Use of energy	187 kW h/m ² a	73 kW h/m ² a	15 kW h/m ² a	8.3 kW h/m ² a	0 kW h/m ² a

Air-tight one-gang boxes, one-gang junction boxes, accessories for cavity wall installation

Processing instructions

"The certificates can be downloaded as PDF files from our website, or can be requested from our technical consultancy department."



The ECON® technology elastic sealing membrane fits itself around the conduit or cable during piercing. This prevents uncontrolled air flows.



The flexible and tool-free insertion of the conduit or cable significantly simplifies the process and reduces installation time.



Reinforcement around the opening prevents tearing of the membrane.



Easy opening of the conduit entry by means of pre-defined opening tab.



Permanently air-tight conduit entry up to conduit size M25.



The conduit can be angled in the entry by up to 90°...

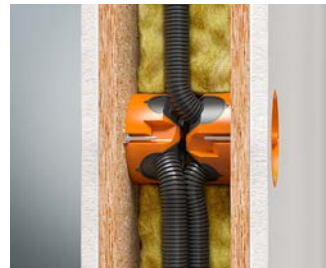

...which is ideal for use in slim wall constructions and installation levels.



The marking of the entry openings simplifies the correct choice of opening size.



Easy-to-fit device fixing thanks to new +/- screw.



The support connector ensures the air-tight combination of the cavity wall boxes and is inserted via the removable metal plates without the use of tools.

O-range ECON® 63 one-gang box



- Air-tight design with sealing membranes
- Fully insulated, air-tight through-wiring for combinations using support connectors
- Toolless cable or conduit entries
- Integrated cable retention of NYM cables, self-locking of conduits



3D animation



Product-Data

Depth	49 mm	49 mm
For panel thickness	7 - 40 mm	7 - 40 mm
Cut hole Ø	68 mm	68 mm
Device screws	2	2
Tube entries up to M25	2	2
Cable entries 3 x 2.5 mm ² or 5 x 1.5 mm ²	2	2
Cable entries 3 x 1.5 mm ²	2	2
Support connectors for each package	7	7
Air-tight	Yes	Yes
Halogen-free	-	Yes
 / 	Yes / Yes	Yes / Yes
Art.-No.	9263-22	9263-78
Inner packaging/shipping	25 / 250	25 / 250

O-range ECON® 64 one-gang junction box



- Air-tight design with sealing membranes
- Fully insulated, air-tight through-wiring for combinations using support connectors
- Toolless cable or conduit entries
- Integrated cable retention of NYM cables, self-locking of conduits



3D animation



Product-Data

Depth	62 mm	62 mm
For panel thickness	7 - 40 mm	7 - 40 mm
Cut hole Ø	68 mm	68 mm
Device screws	2	2
Tube entries up to M25	2	2
Cable entries 3 x 2.5 mm ² or 5 x 1.5 mm ²	3	3
Cable entries 5 x 2.5 mm ² or 7 x 1.5 mm ²	1	1
Cable entries 3 x 1.5 mm ²	3	3
Support connectors for each package	7	7
Air-tight	Yes	Yes
Halogen-free	-	Yes
 / 	Yes / Yes	Yes / Yes
Art.-No.	9264-22	9264-78
Inner packaging/shipping	25 / 250	25 / 250



O-range ECON® 2 / 3 / 4 - gang junction boxes

With the new O-range ECON® 2 / 3 / 4 - gang junction boxes, KAISER offers the perfect basis and especially easy processing for the fitting of all standard installation accessories in multiple combinations. Thanks to their large installation opening without a central separation, it is easy to wire multiple devices together and even makes possible the use of pre-wired installation accessories. If different electrical circuits – e. g. for supply and communication connections – are used within a combination, the individual accessory installation spaces can be separated easily and in a standardised way.

- Easy installation of pre-wired accessories without spatial separation
- Maximum flexibility when fixing accessories, generous tolerance compensation
- Standardised separation of individual installation openings using a bridge
- Complete assembly and installation with just one screwdriver
- Can be combined with all O-range® programme applications



Application examples



The O-range ECON® 2 / 3 / 4 - gang junction boxes...



...allow, thanks to their large installation opening without a separator, the use of pre-wired installation accessories.

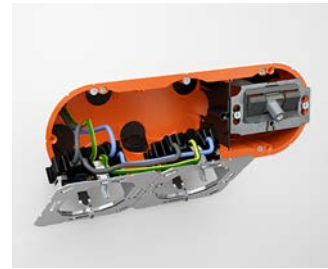

By inserting the separator, different voltage types can be installed in accordance with standards.



O-range ECON® 2 one-gang junction box in a 3-way combination with the O-range ECON® Data (Art. No. 9280-22).

Installation instructions



Mark the centre of the upper installation opening in accordance with DIN 18015-3 and the centre of the other installation openings with 71 mm spacing.

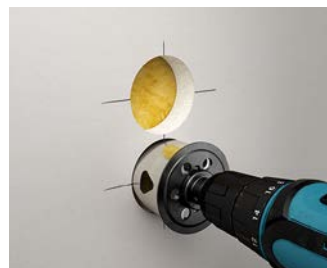

Make Ø 68 mm installation openings with countersinking by using a KAISER cutter (e. g. PROFIL Art. No. 1081-10).

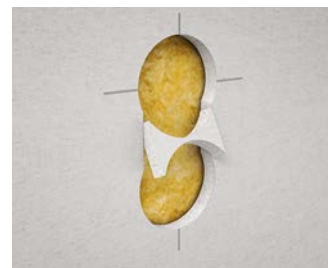

The individual installation openings must now be connected for the insertion of the multiple -gang junction boxes and chamfered for the countersinking.

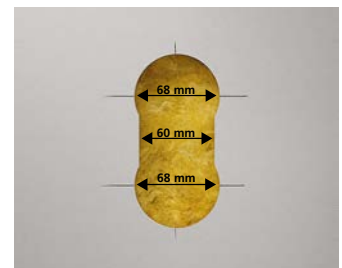

To ensure a perfect seat for the box, always keep to the dimensions shown in the diagram.

O-range ECON® 2 one-gang junction box



- Air-tight design with sealing membranes
- Toolless cable and conduit entries
- Integrated cable retention of the NYM cable, self-locking of the conduit
- Standardised separation of individual installation openings using a bridge
- Can be combined with all O-range® programme applications



INNOVATION



3D animation

Depth	48 mm	48 mm
For panel thickness	7 - 40 mm	7 - 40 mm
Cut hole Ø	2 x 68 mm	2 x 68 mm
Device screws +/-	4	4
Centre distance	71 mm	71 mm
Conduit entries up to Ø 20 mm	4	4
Conduit entries up to Ø 25 mm	2	2
Cable entries 3 x 2.5 mm ² or 5 x 1.5 mm ²	1	1
Cable entries 3 x 1.5 mm ²	1	1
Number of installation device openings	2	2
Halogen-free	-	Yes
 / 	Yes / Yes	Yes / Yes
Art.-No.	9252-22	9252-78
Inner packaging/shipping	10 / 100	10 / 100

O-range ECON® 3 one-gang junction box



- Air-tight design with sealing membranes
- Toolless cable and conduit entries
- Integrated cable retention of the NYM cable, self-locking of the conduit
- Standardised separation of individual installation openings using a bridge
- Can be combined with all O-range® programme applications



INNOVATION



3D animation

Depth	48 mm	48 mm
For panel thickness	7 - 40 mm	7 - 40 mm
Cut hole Ø	3 x 68 mm	3 x 68 mm
Centre distance	71 mm	71 mm
Number of installation device openings	3	3
Number of bridges	1	1
Device screws +/-	6	6
Conduit entries up to Ø 20 mm	6	6
Conduit entries up to Ø 25 mm	2	2
Cable entries 3 x 1.5 mm ²	2	2
Cable entries 3 x 2.5 mm ² or 5 x 1.5 mm ²	2	2
Halogen-free	-	Yes
 / 	Yes / Yes	Yes / Yes
Art.-No.	9253-22	9253-78
Inner packaging/shipping	5 / 50	5 / 50

O-range ECON® 4 one-gang junction box



INNOVATION



3D animation

- Air-tight design with sealing membranes
- Toolless cable and conduit entries
- Integrated cable retention of the NYM cable, self-locking of the conduit
- Standardised separation of individual installation openings using a bridge
- Can be combined with all O-range® programme applications



Depth	48 mm	48 mm
For panel thickness	7 - 40 mm	7 - 40 mm
Cut hole Ø	4 x 68 mm	4 x 68 mm
Device screws +/-	8	8
Centre distance	71 mm	71 mm
Conduit entries up to Ø 20 mm	8	8
Conduit entries up to Ø 25 mm	2	2
Cable entries 3 x 2.5 mm ² or 5 x 1.5 mm ²	2	2
Cable entries 3 x 1.5 mm ²	4	4
Number of bridges	2	2
Number of installation device openings	4	4
Halogen-free	-	Yes
 / 	Yes / Yes	Yes / Yes
Art.-No.	9254-22	9254-78
Inner packaging/shipping	5 / 50	5 / 50

O-range® separator

- for O-range ECON® 2 / 3 / 4 - gang junction box



Art.-No.	5000
Inner packaging/shipping	10 / 100

Conduit one-gang junction box O-range ECON®

Air-tight one-gang junction box with ECON® technology especially for installation with electrical installation conduit. The box is VDE-certified and suitable for energy-efficient electrical installation acc. to GEG. 4 entries are optimal for continuous conduit installation e. g. in prefabricated house construction or with data networks. Extremely easy fitting thanks to toolless conduit insertion with opening tab. The sealing membrane guarantees permanent air-tightness and at the same time retention of the conduit.

- Installation in Ø 68 mm cut hole
- Elastic sealing membrane for guaranteed air-tightness
- Toolless conduit entry
- Can be combined with support connectors, air-tight and fully-insulated



Processing instructions



Easy opening of the conduit entry by means of the opening tab – without any tearing of the membrane.



Air-tight conduit entry up to conduit size M25.

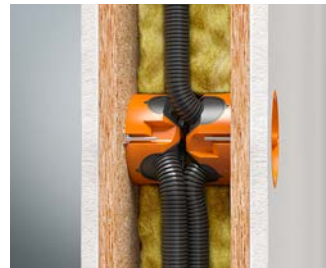

Bending of the conduit up to 90° is easily possible in the case of slim wall constructions or in the installation level.





Air-tight and fully-insulated combination using support connector (Art. No. 9060-98).

O-range ECON® conduit one-gang junction box

- Air-tight design with sealing membranes
- fully-insulated through-wiring for combinations of one-gang junction boxes with support connectors
- toolless conduit entries



3D animation

Depth	62 mm	62 mm
For panel thickness	7 - 40 mm	7 - 40 mm
Cut hole Ø	68 mm	68 mm
Device screws	2	2
Tube entries up to M20	2	2
Tube entries up to M25	2	2
Support connectors for each package	7	7
Air-tight	Yes	Yes
Halogen-free	-	Yes
 / 	Yes / Yes	Yes / Yes
Art.-No.	9266-22	9266-77
Inner packaging/shipping	25 / 250	25 / 250



Junction box 120 mm air-tight

Air-tight Ø 120 mm junction box with ECON® technology for an energy-efficient electrical installation in accordance with GEG. Extremely easy fitting thanks to toolless cable and conduit entry. The sealing membranes guarantee permanent air-tightness and at the same time retention of the cable or conduit. The large box volume provides plenty of installation space for various cable connections.

- Installation in Ø 120 mm cut hole
- Elastic sealing membrane for guaranteed air-tightness
- Toolless cable and conduit entry

NEW

O-range ECON® air-tight IP 30 850 °C **INNOVATION**

Processing instructions



Cut installation opening with Ø 120 mm BASIC cutter (Art. No. 1084-20).



Elastic sealing membrane allows toolless cable and conduit entries in air-tight version.



Fitting of fixing adapter for connection terminals on top-hat rail.

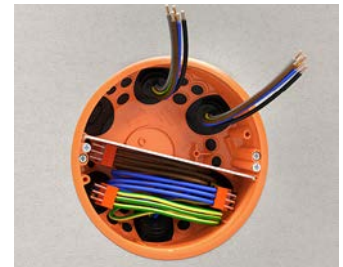

For separation of 2 electrical circuits, use separator wall (Art. No. 9073-20).

Junction box Ø 120 mm O-range ECON®

NEW

- Air-tight design with sealing membranes
- for 2 electrical circuits through separator wall 9073-20
- receptacle for TS 35 standard rail
- with stable holding ring
- Cutting the installation opening with BASIC cutter 1084-20 or VARIOCUT 1089-00
- including cover and screws



3D animation

Depth	65 mm	65 mm
For panel thickness	7 - 40 mm	7 - 40 mm
Cut hole Ø	120 mm	120 mm
Tube entries up to M25	6	6
Cable entries 3 x 2.5 mm ² or 5 x 1.5 mm ²	6	6
Cable entries 5 x 2.5 mm ² or 7 x 1.5 mm ²	4	4
Cable entries 3 x 1.5 mm ²	6	6
Air-tight	Yes	Yes
Halogen-free	-	Yes
/	Yes / Yes	Yes / Yes
Art.-No.	9273-92	9273-78
Inner packaging/shipping	- / 10	- / 10

Installation housing O-range ECON® Universal 120

With the new O-range ECON® Universal 120 installation housing, KAISER offers maximum flexibility on the construction site. In addition to the wiring for an entire room unit, the installation of various accessories or installation accessories is also possible. If necessary, the universal fastening and screw-on surface can be opened to the desired extent, thus ensuring clean installation of recessed luminaires, smoke detectors and much more. Particularly easy to install thanks to tool-free cable and conduit entries. The sealing membranes guarantee permanent air tightness and thus energy-efficient electrical installation in accordance with the Building Energy Act (GEG).

- Universal screw-on surface for clean mounting of attachments without drilling or dowelling
- For creating individual installation openings up to Ø 100 mm
- Complete assembly and installation with just one screwdriver
- Toolless cable and conduit entry
- Installation in Ø 120 mm cut hole



NEW



Mounting as a installation housing



Cut installation opening Ø 120 mm with KAISER BASIC cutter (Art. No. 1084-20).



Chamfer the installation opening for mounting flush with the ceiling or wall using a cutter knife.



Insert the connection line through the elastic sealing membrane without tools.



Fasten the universal screw-on surface using the two device screws.

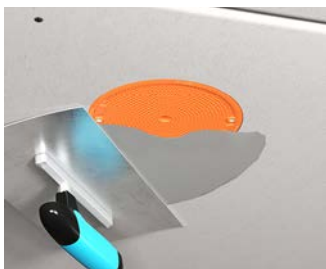

Putty over the assembled installation housing with commercially available filler.



Create a round installation opening (max. Ø 100 mm) using a KAISER cutter...



...or a square installation opening (max. 75 x 75 mm), e.g. with a fretsaw.



Connection and installation of a built-in luminaire (up to max. 50 mm installation depth).

Universal installation housings

for cavity wall installation

Installation notes

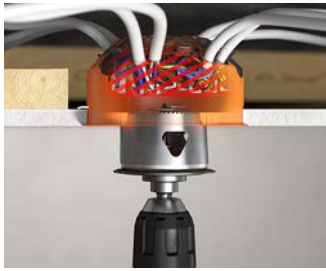

When creating the installation opening, pay attention to the cutting depth to ensure not to damage the cable material in the installation housing!

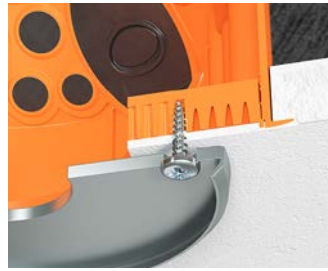

When attaching the device to the installation housing, use only screws that go into but not right through the screw-on surface (e.g. screw with half-round head 3.5 x 15 mm)!



When filling the suspended ceiling, the signal cover (Art. No. 1281-31 /-32 /-33) protects the wiring and the interior of the housing.



Design freedom for creative, modern lighting systems in the wall and the ceiling.



Installation housing O-range ECON® Universal 120

NEW

- With universal screw-on surface for mounting accessories and installation accessories
- For individual round and cornered installation openings
- Air-tight design with sealing membranes
- Toolless cable or conduit entries
- Integrated cable retention of NYM cables, self-locking of conduits



INNOVATION

Depth	65 mm
For panel thickness	7 – 40 mm
Cut hole Ø	120 mm
max. opening size Ø	100 mm
max. square opening size Ø	75 x 75 mm
max. luminaire installation diameter	86 mm
For devices with an installation depth of max.	50 mm
max. lamp output LED	8 Watt
Conduit entries up to Ø 25 mm	6
Cable entries 3 x 1.5 mm ²	6
Cable entries 3 x 2.5 mm ² or 5 x 1.5 mm ²	6
Cable entries 5 x 2.5 mm ² or 7 x 1.5 mm ²	4
Air-tight	Yes
 / 	Yes / Yes
Art.-No.	9273-50
Inner packaging/shipping	- / 10

One-gang junction box O-range ECON® Fix

With the new O-range ECON® Fix junction box, installation is significantly faster and easier thanks to the latchless clamping ribs for fastening in various wall material combinations such as OSB boards, gypsum fibre boards or even in exposed masonry. Circumferential sealing lamellas on two levels guarantee that the airtight level is maintained. The centring bars enable convenient mounting of the device junction box in the installation opening without canting. PLUG - ALIGN - CLAMP - READY!

- Clamping rib fastening for different solid wall constructions
- Circumferential sealing lamellas on 2 levels to maintain the airtight level
- 4 screw domes for maximum flexibility for accessory fitting
- Toolless cable and conduit entry
- Device screws with plus-minus drive



Examples of use



Wall construction OSB board with plasterboard.



Wall construction OSB board with Mdf.



Wall construction Gypsum fibreboard.*



Exposed brickwork.

Note

O-range ECON® Fix junction boxes are suitable for secure fixing in multi-layer wall structures, such as OSB boards in conjunction with gypsum plasterboards (GKB), in walls made of cross laminated timber, glulam, solid wood walls as well as in single-layer wall structures made of gypsum fibre boards (GF) according to DIN EN 15283-2. They can also be used for installations in exposed brickwork.* For installation in wall structures consisting exclusively of plasterboard (GKB) in accordance with DIN 18180 or cement-bonded mineral fibre boards in accordance with DIN EN 12467, the O-range® product range with lug fastening is the appropriate solution.



Air-tight one-gang boxes, one-gang junction boxes, accessories for cavity wall installation

One-gang junction box O-range ECON® Fix

INNOVATION





3D animation



Product-Data

- Clamping ribs fastening in building materials from 10 mm thickness, e.g. wall constructions with OSB boards, gypsum fibre boards and exposed masonry
- 4 screw domes
- Air-tight design with sealing membranes
- Toolless cable or conduit entries
- Fully insulated, air-tight through-wiring for combinations using support connectors
- Integrated cable retention of the NYM cable, self-locking of the conduit
- including setting tool (Art.No.1090-12) per packaging unit



Depth	62 mm	62 mm
Cut hole Ø	68 mm	68 mm
Device screws +/-	2	2
Conduit entries up to Ø 25 mm	2	2
Cable entries 3 x 1.5 mm ²	3	3
Cable entries 3 x 2.5 mm ² or 5 x 1.5 mm ²	3	3
Air-tight	Yes	Yes
Halogen-free	-	Yes
 / 	Yes / Yes	Yes / Yes
Art.-No.	9264-12	9264-72
Inner packaging/shipping	25 / 250	25 / 250

Setting tool O-range ECON® Fix

- For quick and safe installation of the O-range ECON® Fix junction box (Art. No. 9264-12 / 9264-72)
- Also suitable for easy alignment of most Kaiser cavity wall boxes with a cut hole diameter of 68 mm, such as Art. No. 9063-XX, 9064-XX, 9263-XX, 9264-XX, etc. (not suitable for e.g. Art. No. 9268-XX, 9280-XX)



Art.-No.	1090-12
Inner packaging/shipping	10 / 100

Electronics box O-range ECON® Flex

Air-tight O-range ECON® Flex electronics box with ECON® technology for energy-efficient electrical installation in accordance with GEG. Fast installation is ideal for modernising or extending existing systems. The flexible tunnel makes it easy to install, and creates space for electronic components, cable reserves and terminals.

- Additional sideway terminal compartment for communications and network technology
- Elastic sealing membrane for guaranteed air-tightness
- Toolless cable and conduit entry
- Integrated cable retention
- Can be combined with support connectors, air-tight and fully-insulated



Examples of use

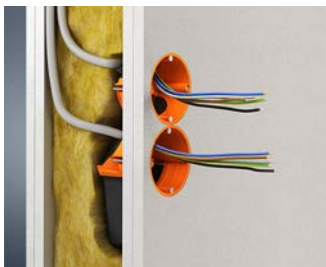

Combination with ECON® cavity wall boxes is possible.



Additional space for connection terminals.



Accepts electronic components e.g. actuators.

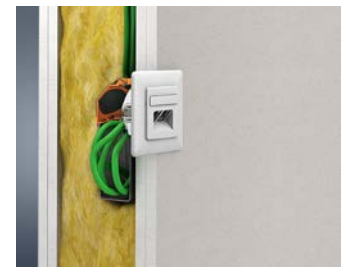

Space for cable reserves.

Electronics box O-range ECON® Flex

- for accessories and electronic components
- Air-tight design with sealing membranes
- Elastic tunnel
- Combinable with ECON® one-gang junction boxes



3D animation



Product-Data

Length x Width x Depth	122 x 71 x 75 mm	122 x 71 x 75 mm
For panel thickness	7 - 30 mm	7 - 30 mm
Cut hole Ø	68 mm	68 mm
Device screws	2	2
Tube entries up to M25	2	2
Cable entries 3 x 2.5 mm ² or 5 x 1.5 mm ²	2	2
Cable entries 3 x 1.5 mm ²	2	2
Air-tight	Yes	Yes
Halogen-free	-	Yes
/	Yes / Yes	Yes / Yes
Art.-No.	9268-94	9268-74
Inner packaging/shipping	10 / 100	10 / 100



One-gang connection box O-range ECON® Data

With the new O-range ECON® Data one-gang connection box, KAISER offers unprecedented ease of installation for the fitting and connection of communication and network connection boxes. The innovative cable entries for data and network cables are positioned in such a way that it is very easy to maintain the bending radii specified by the cable manufacturer. This prevents kinks in the cable, and ensures optimal data transfer. Whether you are fitting a network connection box or a Keystone module, the new O-range ECON® Data always provides optimal cable routing.

- Innovative cable entries prevent kinks in the cables
- 4 screw domes for maximum flexibility for accessory fitting
- Toolless cable and conduit entry
- Complete assembly and installation with just one screwdriver
- Can be combined with all O-range® programme applications



Application examples



Thanks to optimally-positioned cable entries, Keystone modules can quickly and easily be fitted - no kinks in the cable! - inside the O-range ECON® Data one-gang junction box...



...push the data and network cables into the lightweight wall's cavity.



The O-range ECON® Data one-gang connection box also offers easy cable feeding to the accessory for the fitting of network connection boxes...



...in order to fit the cable reserve in the lightweight wall's cavity.



The large number of different cable and conduit entries allows the installation of media converters...



...in which supply is always by means of NYM cables and installation conduits up to Ø 25 mm - so the connection is always the right one.



For conventional electrical installation work, and in addition to combinability with all applications in the O-range® programme, the O-range ECON® Data one-gang connection box...



...also offers plenty of space for convenient fitting of multiple connection terminals.

Installation of Keystone modules

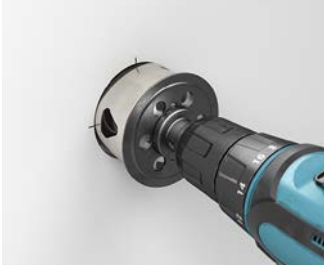

Make Ø 68 mm installation opening with countersinking using a KAISER cutter (e. g. PROFI with Art. No. 1081-10).



Toolless insertion of data and network cables through the elastic sealing membrane.

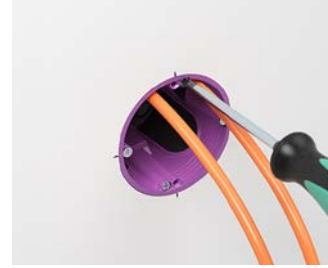

Insert the O-range ECON® Data one-gang connection box into the installation opening, use the centre marking for alignment, and tighten the lug screws.



Feed the data and network cables back into the lightweight wall's cavity and fix the accessory by means of the device screws.

Installation of network junction boxes



Toolless insertion of data and network cables through the cable entries in the elastic sealing membrane.



For box installation, insert the cables from the outside into the membrane so that the box can be put into the installation opening.



Put the O-range ECON® Data accessory connection box into the installation opening, align it by means of the centre marking, and tighten the lug screws.

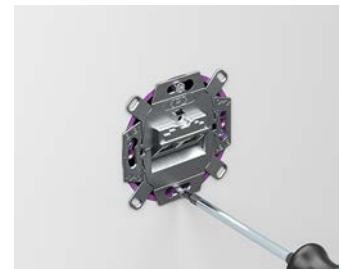

Feed the data and network cables back into the cavity of the lightweight wall. Fix the installation accessory in position by means of the device screws.

One-gang connection box O-range ECON® Data



- for network, coaxial, NYM and communication lines
- 4 screw domes
- Air-tight design with sealing membranes
- Toolless cable or conduit entries
- integrated NYM cable retention, self-locking of the communication cables and conduits
- Can be combined with all O-range® programme applications



INNOVATION



3D animation

Depth	74 mm	74 mm
For panel thickness	7 - 40 mm	7 - 40 mm
Cut hole Ø	68 mm	68 mm
Conduit entries up to Ø 25 mm	2	2
Cable entries 3 x 2.5 mm ² or 5 x 1.5 mm ²	1	1
Cable entries 3 x 1.5 mm ²	2	2
Entries for communication cables	6	6
Air-tight	Yes	Yes
Halogen-free	-	Yes
 / 	Yes / Yes	Yes / Yes
Art.-No.	9280-22	9280-78
Inner packaging/shipping	10 / 100	10 / 100

Air-tight one-gang boxes, one-gang junction boxes, accessories for cavity wall installation

One-gang box for thin boardings

- for boardings that do not permit any countersinking
- Combinations only possible with boxes with the same Art. No.
- with thin holding ring





Depth	47 mm	47 mm
Cut hole Ø	68 mm	68 mm
For panel thickness	0,2 - 40 mm	0,2 - 40 mm
Device screws	2	2
Cable entries up to max. Ø 10.5 mm can be made using universal opening cutter Art. No. 1085-80	Yes	Yes
Air-tight	Yes	Yes
Halogen-free	-	Yes
	Yes	Yes
Art.-No.	9068-01	9068-79
Inner packaging/shipping	10 / 100	10 / 100

Cavity wall one-gang junction box

- incl. 10 connection pieces (for every 25 boxes)
- with holding ring



Depth	65 mm	65 mm
Cut hole Ø	68 mm	68 mm
For panel thickness	7 - 40 mm	7 - 40 mm
Cable or conduit entries to max. Ø 25 mm cut using universal opening cutter Art. No. 1085-80	Yes	Yes
Device screws	2	2
Air-tight	Yes	Yes
Halogen-free	-	Yes
 / 	Yes / Yes	Yes
Art.-No.	9066-01	9066-77
Inner packaging/shipping	25 / 250	25 / 250

Accessories: Support connector, air tight, Page 96/114

One-gang junction box for solid wood

- for clamped attachment in solid wood from 10 mm thickness upwards
- not suitable for use with plasterboard or mineral fibreboard!
- with holding ring



Depth	65 mm
Cut hole Ø	68 mm
Device screws +/-	2
Cable or conduit entries to max. Ø 25 mm cut using universal opening cutter Art. No. 1085-80	4
Air-tight	Yes
/	Yes / Yes
Art.-No.	9066-12
Inner packaging/shipping	25 / 250

Accessories: Support connector, air tight, Page 96/114

One-gang box CEE

- for use with 16A CEE equipment inserts
- with holding ring



	50 mm	50 mm
Cut hole Ø	74 mm	74 mm
Screw spacing	67 mm	67 mm
For panel thickness	12,5 - 40 mm	12,5 - 40 mm
Cable entries up to max. Ø 10.5 mm can be made using universal opening cutter Art. No. 1085-80	Yes	Yes
Air-tight	Yes	Yes
Halogen-free	-	Yes
	Yes	Yes
Art.-No.	9075-12	9075-78
Inner packaging/shipping	10 / 100	10 / 100

Air-tight one-gang boxes, one-gang junction boxes, accessories for cavity wall installation

Electronics box

- air-tight version with additional sealing lip
- Tunnel twin-chamber box with enclosed separator wall and cover that can be wallpapered over.
- for accessory inserts and electronic components, such as EIB actuators, communication technology, radio control elements, alarm modules, etc.
- with holding ring



Depth	75 mm	75 mm
Centre distance	71 mm	71 mm
Cut hole Ø	2 x 68 mm	2 x 68 mm
Air-tight	Yes	Yes
Halogen-free	-	Yes
	Yes	Yes
Art.-No.	9062-94	9062-74
Inner packaging/shipping	10 / 100	10 / 100

Wall light connection box

- with inner fitting cover
- not to be used as a junction box!
- for 3 terminal blocks



Depth	45 mm	45 mm
Cut hole Ø	35 mm	35 mm
For panel thickness	7 - 40 mm	7 - 40 mm
Cable entries 3 x 1.5 mm ²	1	1
Air-tight	Yes	Yes
Halogen-free	-	Yes
Art.-No.	9248-01	9248-77
Inner packaging/shipping	25 / 100	25 / 100

Support connector

- For fully insulated through-wiring in combinations
- to make air-tight combinations
- for Art. Nos. 9066-01/12, 9068-01, 9263-..., 9264-..., 9062-02/-77, 9062-94/-74, 9268-94/-74, 9266-22/-77



Halogen-free	-	Yes
Art.-No.	9060-98	9060-78
Inner packaging/shipping	25 / 100	25 / 100

Universal VDE cover

- for all one-gang, one-gang junction and junction boxes
- with central exit for light hook
- flat cover edge
- surface roughened



Diameter	92 mm	92 mm
Screw spacing	60 / 67 mm	60 / 67 mm
Fireproof	850 °C	850 °C
Halogen-free	-	Yes
	Yes	Yes
Art.-No.	1184-90	1184-77
Inner packaging/shipping	25 / 250	25 / 250

Universal waterproof cover

- central entry with stoppers
- for countersunk screws Ø 4 mm



Diameter	90 mm	90 mm
Screw spacing	67 mm	60 mm
Fireproof	850 °C	850 °C
Halogen-free	Yes	Yes
Art.-No.	1174-99	1174-98
Inner packaging/shipping	10 / -	10 / -

Internal cover

- for flush closure of one-gang boxes and one-gang junction boxes
- suitable for wallpapering
- for all one-gang boxes and one-gang junction boxes



Diameter	64 mm
Halogen-free	Yes
Art.-No.	1158-90
Inner packaging/shipping	25 / 250

FLUSH-MOUNTING

CAVITY WALL

CONCRETE

HOUSINGS

FIRE PROTECTION

PLUGGABLE

CONNECTIVITY

CABLE GLANDS

TOOLS

SERVICE

Sealing foil

Sealing foil for later sealing of over-sized, non-circular or broken-out openings, as often found with combinations in plasterboard, mineral fibreboard or similar materials, which are guaranteed to be sealed air-tight with the sealing foil.

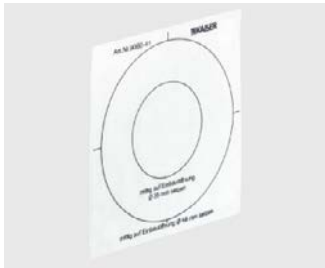

Sealing foil

- for sealing between box edge and boarding material with oversized, non-circular or broken-out drill holes (e.g. in combination areas with plasterboard, mineral fibreboard or similar materials)
- for Art. No. 9066-01/77, 9068-01/79, 9248-01, 9263-..., 9264-...



Air-tight	Yes
Art.-No.	9060-41
Inner packaging/shipping	25 / -

Sealing inserts

Sealing insert for retrofit sealing of existing installation boxes in air-tight building shells. The insert encloses the cables and creates a guaranteed air-tight installation space.



Sealing inserts

- for retrofit sealing of all existing one-gang boxes and one-gang junction boxes
- permanently flexible plastic



Depth	36,5 mm
Diameter	60 mm
Air-tight	Yes
Halogen-free	Yes
Art.-No.	1040-01
Inner packaging/shipping	10 / 100

Assignment of conduit sizes and sealing plugs

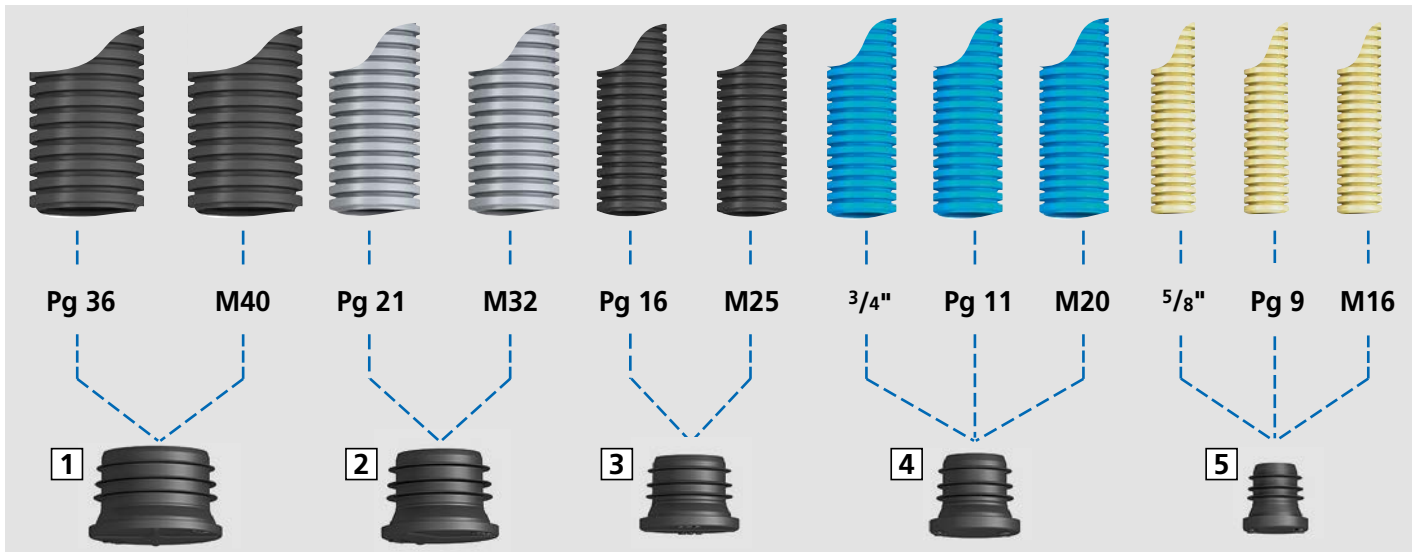

1 Sealing plug M40 Art. No. 1040-40 | 2 Sealing plug M32 Art. No. 1040-32 | 3 Sealing plug M25 Art. No. 1040-25 | 4 Sealing plug M20 Art. No. 1040-20 | 5 Sealing plug M16 Art. No. 1040-16

Sealing plugs 16-20

- for sealing electrical installation conduits
- ECON® technology for easy cable entry
- permanently flexible plastic



3D animation

Sealing plug	M16	M20
DIN EN conduit Ø	16 mm	20 mm
Halogen-free	Yes	Yes
Art.-No.	1040-16	1040-20
Inner packaging/shipping	25 / 100	25 / 100

Sealing plugs 25-40

- for sealing electrical installation conduits
- ECON® technology for easy cable entry
- permanently flexible plastic



3D animation

Sealing plug	M25	M32	M40
DIN EN conduit Ø	25 mm	32 mm	40 mm
Halogen-free	Yes	Yes	Yes
Art.-No.	1040-25	1040-32	1040-40
Inner packaging/shipping	25 / 100	25 / 50	- / 25



NEW

One-gang junction box for solid wood

The new one-gang junction box for solid wood (CLT) makes installation in solid wood walls much quicker, easier and more efficient thanks to lug-free rib fastening. Thanks to the innovative cable entries, which enable toolless installation, even out-of-direction drill holes for cable routing in the CLT element can be effortlessly levelled out and guarantee clean installation in the installation opening, even in visible wood quality. The centring bars and the centre markings on the holding ring and on the first row of ribs enable precise and convenient alignment of the one-gang junction box in the installation opening without tilting.

- Clamping rib fastening for installation in solid wood walls / CLT
- Innovative cable entries enable maximum tolerance compensation for out-of-direction drill holes for the cable route
- Four screw domes for maximum flexibility for accessory fitting
- Eight toolless cable entries
- Device screws with plus-minus drive



INNOVATION

Application examples



Ideally suited for installation in solid wood elements with visible wood quality.



For directly opposing installation in walls from 120 mm overall thickness.



Fully insulated connection for two- to five-fold box combinations by means of support connectors (Art. No. 9060-88).



Firm hold thanks to the rib fastening, even with subsequent boarding (e.g. gypsum plasterboard).

Processing instructions



For installation openings \varnothing 74 mm, for multiple combinations at the standardised centre distance of 71 mm.



Toolless cable entries up to \varnothing 11.5 mm.



The innovative cable entries ideally compensate for out-of-direction drill holes and ensure an optimum cable connection to the box.



The box is simply pressed into the \varnothing 74 mm installation opening of the solid wood wall using the setting tool (Art. No. 1090-12).

Installation



Create the exact installation opening \varnothing 74 mm, for multiple combinations at the standardised centre distance of 71 mm.



Open the toolless cable entries and insert the cables up to \varnothing 11.5 mm.



Align the box for exact positioning using the centre markings on the holding ring and on the first row of ribs.



When installing the box, the cables press into the membrane from the outside so that the box can be guided into the installation opening.



The box is simply pressed into the \varnothing 74 mm installation opening of the solid wood wall using the setting tool (Art. No. 1090-12).



For fully insulated connection in multiple combinations, the support connector (Art. No. 9060-88) is inserted into the open cable entry.

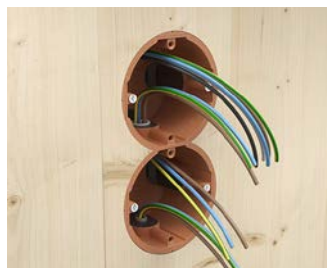

The connecting cables are then fed through the support connector.



Fasten the installation accessory using the device screws.

One-gang junction box for solid wood / CLT

NEW

- Rib fastening for installation in cross-laminated timber or laminated timber walls or in solid wood panels
- Innovative cable entries positioned on the side of the box circumference
- 4 screw domes
- Toolless opening of the cable entries using an opening tab
- Fully insulated through-wiring for combinations using support connectors
- including setting tool (Art.No.1090-12) per packaging unit



INNOVATION



3D animation

Depth	60 mm
Cut hole \varnothing	74 mm
Screw spacing	60 mm
Number of screw domes	4
Cable entries of up to \varnothing 11.5 mm	8
Support connectors for each package	7
Combination distance by simply removing the pre-embossed edge	71 mm
Art.-No.	9274-22
Inner packaging/shipping	25 / 250

90° wall and ceiling transitions



NEW

The new KAISER 90° wall and ceiling transitions for prefabricated house and modular construction guarantee an air-tight component seal at transition points and solve the problem of protruding electrical installation conduits. This ensures smooth transport of the wall elements or modules to the construction site and eliminates the additional work step of sealing the transition point on site. The innovative transitions for front or rear installation of the empty conduit system in serial production ensure flexible cable pull-in from both directions. The 90° bend and clean catch mechanism to the wall connection element prevent abutting edges. Thanks to its multi-part design, it can be optimally integrated into modern production processes.

- For airtight connection of electrical installation conduits at transition points
- Flexible cable pull-in from both directions thanks to 90° bend without abutting edges
- Universally applicable in different wall structures
- No damage to the cables
- Ensuring the continuous empty conduit installation
- No time-consuming and cost-intensive reworking on the construction site



Application examples



No protruding conduits and therefore convenient transport to the construction site.



The electrical installation conduit can be connected easily and air-tight on the construction site (e.g. above the unfinished floor).

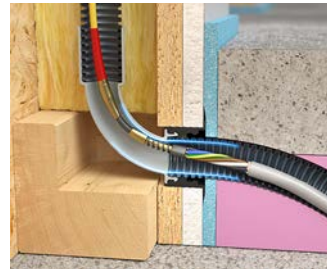

The new 90° wall and ceiling transitions have an optimised radius without abutting edges, thus allowing cables to be pulled in flexibly.

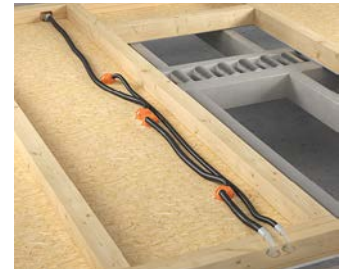

Pre-assembled sub-assemblies enable optimum integration into modern production processes.

Processing instructions

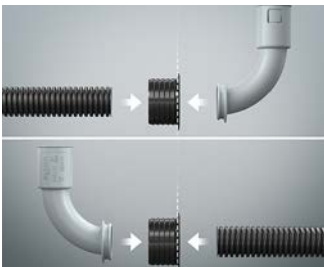

The wall connection element can be used on both sides for 90° bends and electrical conduit.



Peripheral sealing ribs clamp the wall connection element permanently air-tight and secure in the wall boarding.



No abutting edges thanks to a clean transition from the electrical installation conduit to the 90° bend.



The clean and defined conduit transition at transition points prevents time-consuming and costly reworking steps on the construction site.

Installation in open wall unit



Machine creation of the exact installation opening of Ø 38 mm.



Fixing the wall connection element through the peripheral sealing ribs in the wall boarding.



Attach the 90° bend to the electrical installation conduit and...



...snap into the already mounted wall connection element.

Installation in closed wall element



Machine creation of the exact installation opening of Ø 38 mm.



The protruding electrical installation conduit is inserted into the conduit holder of the 90° bend up to the depth stop and locked in place.



After attaching the wall connection element, the wall and ceiling transition is guided 90° through the installation opening back into the wall element...



...and firmly clamped in the wall boarding.

90° wall and ceiling transition

NEW

- Two-part design with secure catch mechanism
- Air-tight component closure for front and rear installation in the boarding of wall elements or modules
- Flexible cable pull-in from both directions thanks to 90° bend without abutting edges
- Wall connection element can be used on both sides for 90° bends and electrical conduit
- Flat collar for a firm and flush fit in the wall element



INNOVATION

Length x Width x Height	102 x 47 x 73,5 mm	102 x 47 x 76 mm
DIN EN conduit Ø	20 mm	25 mm
for cut hole Ø	38 mm	38 mm
Number of parts	2	2
Art.-No.	9261-20	9261-25
Inner packaging/shipping	- / 100	- / 100



Sealing sleeves

The KAISER range of sealing sleeves offers perfect sealing for all standard cable and conduit sizes, both indoors and outdoors. The range consists of single and double sleeves for one or two cables or conduits respectively, and of two multiple air-tight sleeves for up to six cables or conduits. The self-adhesive KAISER sealing sleeves can be fitted without the need for any tools. Talcum is applied to the sleeves before they leave the factory. They ensure easy cable or conduit feed-through, and fast processing on the building site. In contrast to the conventional improvised method, KAISER sealing sleeves guarantee the permanent air-tight sealing of installation penetrations.

- For cables Ø 4 - 15 mm and conduits Ø 15 - 110 mm
- Large contact area to cables and conduits
- Anti-kink sleeve also permanently seals very kinked cables
- Completely toolless wall installation
- Extremely good adhesion



Applications for sealing sleeves

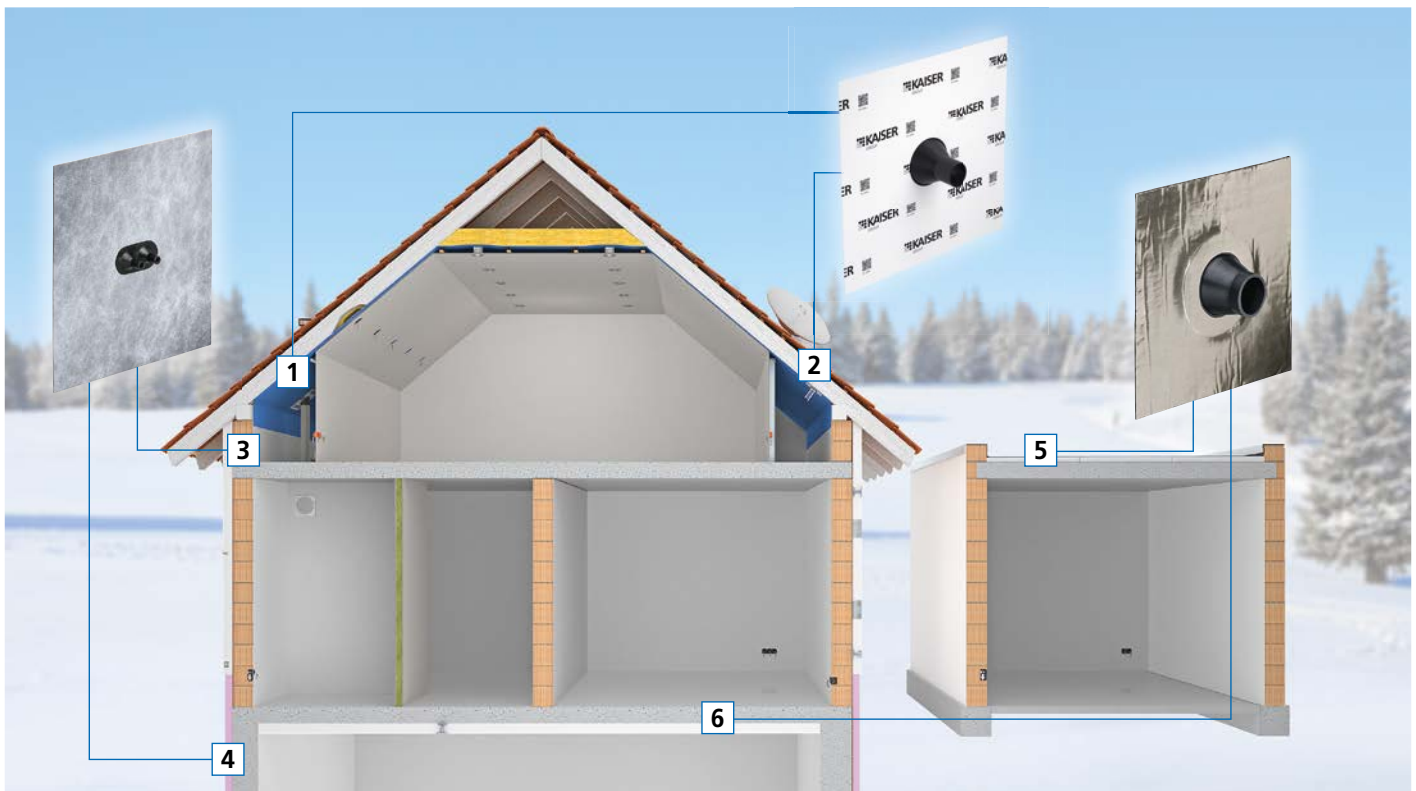

1 Sealing of a ventilation conduit through the vapour or moisture barrier | **2** Sealing of more than one cable through the vapour or moisture barrier | **3** Sealings in plastered walls | **4** Sealings in the cellar area | **5** Sealings in flat roof areas | **6** Sealing of the cellar ceiling or the foundation baseplate



Air-tight sleeve



Fleece-butyl sealing sleeve



Aluminium butyl sealing sleeve

Applications

Indoors

Indoors & outdoors

Indoors & outdoors

	L x B	H	Ø mm	Art. No.	Art. No.	Art. No.
Cables (coaxial, NYM, underground, solar, etc.)						
Single			4–8 mm	9059-44	9089-44	9079-44
			8–12 mm	9059-46	9089-46	9079-46
			12–15 mm	9059-56	9089-56	9079-56
Double			4–8 mm	9059-45	9089-45	9079-45
			8–12 mm	9059-47	9089-47	9079-47
6 combinations			4–11 mm	9059-61	-	-
Conduits (electrical installation, waste water, ventilation, heating, etc.)						
Single			15–22 mm	9059-48	9089-48	9079-48
			25–32 mm	9059-49	9089-49	9079-49
Double			15–22 mm	9059-55	9089-55	9079-55
Single			42–55 mm	9059-51	9089-51	9079-51
			50–75 mm	9059-52	9089-52	9079-52
			75–90 mm	9059-53	9089-53	9079-53
			100–110 mm	9059-54	9089-54	9079-54
6 combinations			16–25 mm	9059-62	-	-

Examples of use

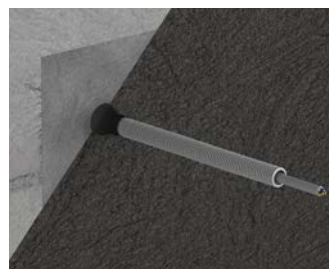

Air-tight sleeve

Air-tight sleeve for sealing conduit and cable entries in the interior of air-tight building shells.

- extremely strong adhesion
- For guaranteed air-tight feed-throughs, especially in the attic
- 12 types for different conduit and cable diameters
- Suitable for moisture barrier foils, sarking membranes, OSB boards *



Examples of use



Processing instructions

Air-tight conduit entries can be made cleanly and easily by using the self-adhesive KAISER air-tight sleeves. The sleeves create faster, more stable and, above all, more air-tight transitions than improvised methods. Please ensure that the base is dry and free from dust and grease. Processing should be carried out at a temperature higher than -5°C, and full adhesive strength is achieved after 24 hours. The sleeves have an unlimited shelf life when stored cool and dry at room temperature. * For fibreboard, we recommend a pre-coat using primer

Air-tight sleeves for cables and conduits

- Continuous sealing by means of air-tight layers for penetration of cables
- extremely strong adhesion
- Temperature resistance -30°C to +80°C, in the feed-through area up to +120°C
- UV-resistant, halogen-free



Length x Width x Height	Number of cables/ conduits	Diameter of cable / pipe	Air-tight	Art.-No.	Inner packaging/ shipping
150 x 150 x 30 mm	1 item	4 - 8 mm	Yes	9059-44	10 / 30
150 x 150 x 30 mm	2 item	4 - 8 mm	Yes	9059-45	10 / 30
150 x 150 x 30 mm	1 item	8 - 12 mm	Yes	9059-46	10 / 30
150 x 150 x 30 mm	2 item	8 - 12 mm	Yes	9059-47	10 / 30
150 x 150 x 30 mm	1 item	12 - 15 mm	Yes	9059-56	10 / 30
150 x 150 x 30 mm	1 item	15 - 22 mm	Yes	9059-48	10 / 30
150 x 150 x 30 mm	2 item	15 - 22 mm	Yes	9059-55	10 / 30
150 x 150 x 30 mm	1 item	25 - 32 mm	Yes	9059-49	10 / 30
230 x 230 x 50 mm	1 item	42 - 55 mm	Yes	9059-51	- / 8
230 x 230 x 50 mm	1 item	50 - 75 mm	Yes	9059-52	- / 4
230 x 230 x 50 mm	1 item	75 - 90 mm	Yes	9059-53	- / 4
320 x 320 x 50 mm	1 item	100 - 110 mm	Yes	9059-54	- / 4

Multiple air-tight sleeves ECON®

Cable and conduit sleeve ECON® for reliable sealing of up to 6 cable or conduit entries through the air-tight building shell - ideal for digital satellite units.

- Flexible sealing of 1 to 6 cables or conduits
- Low space requirement, powerful adhesion
- Completely toolless wall installation
- Sealing even when cables are extremely kinked
- Unused entries are reserved for later installations



Examples of use



Connection of a digital satellite receiver unit.



4 coaxial cables are connected here for reception.



The mast which supports the parabolic mirror must also be incorporated in the equipotential bonding.

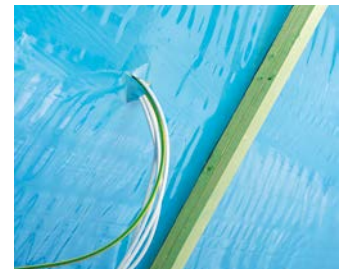

The cables are fed through the building's air-tight seal. This entry must be permanently sealed air-tight.

Installation



ECON® technology's toolless cable or conduit entry offers maximum ease of installation and permits fast processing.



Before the sleeve can be glued in position, make sure that the surface is free of dust. Then remove the protective foil,...



...glue the sleeve in position and thoroughly smooth it onto the surface, working from the inside to the outside.



The sleeves guarantee permanent sealing of entries, even when cables are extremely kinked. Retrofitting is easy.

Product advantages

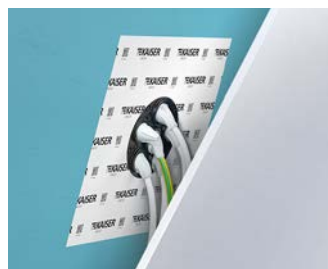

Sealing sleeves

Reliable sealing of installation feed-throughs

Cable-sleeve ECON®

- 1-piece
- extremely strong adhesion
- Temperature resistance from -25°C to +80°C
- UV-resistant, halogen-free



3D animation

Length x Width x Height	230 x 230 x 25 mm
Number of cable entries	1 - 6
Cable diameter	4 - 11 mm
Art.-No.	9059-61
Inner packaging/shipping	- / 5

Conduit-sleeve ECON®

- 1-piece
- extremely strong adhesion
- Temperature resistance from -25°C to +80°C
- UV-resistant, halogen-free



3D animation

Length x Width x Height	320 x 320 x 30 mm
Number of conduit entries	1 - 6
Conduit diameter	16 - 25 mm
Art.-No.	9059-62
Inner packaging/shipping	- / 5

Fleece-butyl sealing sleeves

For permanent, secure sealing of installation penetrations in masonry, concrete or wood materials, etc. The highly-elastic sleeves are fitted with fleece-butyl flanges as plaster bases and provide maximum adhesion. Some surfaces must be pre-treated with KAISER primer.

- Permanently moisture-proof - for use indoors and outdoors
- The fleece sleeve can be plastered over, and is for use in plastered walls and behind composite thermal insulation systems
- Waterproofing effect with non-pressing water, e.g. against soil moisture



Installation



If necessary, pre-treat the base, pull the sleeve over the cable/conduit...



...remove the protective foil and press the sleeve into position.

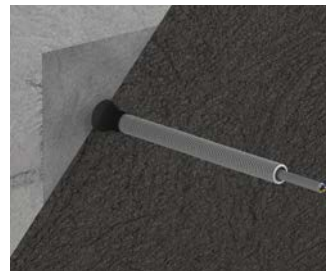

The adhesive flange can be plastered over and ensures permanent sealing of the masonry penetration.

Note

To ensure secure adhesion of all KAISER air-tight sleeves, the bases must be free of dust and grease, and also dry and load-bearing. In particular, mineral and organic bases such as stone, concrete, plasterboard or fibreboard must be pre-treated with KAISER primer.

Fleece-butyl sealing sleeves

- For cables Ø 4 - 15 mm and conduits Ø 15 - 110 mm
- Fleece-butyl sealing sleeve can be plastered over
- adhesive
- 1-piece



Length x Width x Height	Number of cables/ conduits	Diameter of cable / pipe	Air-tight	Art.-No.	Inner packaging/ shipping
150 x 150 x 30 mm	1 item	4 - 8 mm	Yes	9089-44	10 / 30
150 x 150 x 30 mm	2 item	4 - 8 mm	Yes	9089-45	10 / 30
150 x 150 x 30 mm	1 item	8 - 12 mm	Yes	9089-46	10 / 30
150 x 150 x 30 mm	2 item	8 - 12 mm	Yes	9089-47	10 / 30
150 x 150 x 30 mm	1 item	12 - 15 mm	Yes	9089-56	10 / 30
150 x 150 x 30 mm	1 item	15 - 22 mm	Yes	9089-48	10 / 30
150 x 150 x 30 mm	2 item	15 - 22 mm	Yes	9089-55	10 / 30
150 x 150 x 30 mm	1 item	25 - 32 mm	Yes	9089-49	10 / 30
230 x 230 x 50 mm	1 item	42 - 55 mm	Yes	9089-51	- / 4
230 x 230 x 50 mm	1 item	50 - 75 mm	Yes	9089-52	- / 4
230 x 230 x 50 mm	1 item	75 - 90 mm	Yes	9089-53	- / 4
320 x 320 x 50 mm	1 item	100 - 110 mm	Yes	9089-54	- / 4



Aluminium-butyl sealing sleeves

For permanent, secure sealing of installation penetrations through masonry, concrete or wooden materials. The highly-elastic sleeves are fitted with non-tear aluminium butyl adhesive flanges and provide maximum adhesion. Some surfaces must be pre-treated with KAISER primer.

- Permanently moisture-proof - for use indoors and outdoors
- Water-sealing effect with non-pressing water up to 0.02 bar
- Especially suitable for sealing in the cellar socle
- Large contact area to cables and conduits
- Anti-kink sleeve also permanently seals very kinked cables
- Completely toolless wall installation
- Extremely good adhesion



Installation



Pre-treat mineral bases and fibreboards with primer.



Pull the sleeve over the cable/conduit and remove the protective foil.



Press the adhesive flange of the sleeve firmly into position.

Aluminium-butyl sealing sleeves

- For cables Ø 4 - 15 mm and conduits Ø 15 - 110 mm
- pressing water up to 0.02 bar
- adhesive
- 1-piece



Length x Width x Height	Number of cables/ conduits	Diameter of cable / pipe	Air-tight	Art.-No.	Inner packaging/ shipping
150 x 150 x 30 mm	1 item	4 - 8 mm	Yes	9079-44	10 / 30
150 x 150 x 30 mm	2 item	4 - 8 mm	Yes	9079-45	10 / 30
150 x 150 x 30 mm	1 item	8 - 12 mm	Yes	9079-46	10 / 30
150 x 150 x 30 mm	2 item	8 - 12 mm	Yes	9079-47	10 / 30
150 x 150 x 30 mm	1 item	12 - 15 mm	Yes	9079-56	10 / 30
150 x 150 x 30 mm	1 item	15 - 22 mm	Yes	9079-48	10 / 30
150 x 150 x 30 mm	2 item	15 - 22 mm	Yes	9079-55	10 / 30
150 x 150 x 30 mm	1 item	25 - 32 mm	Yes	9079-49	10 / 30
230 x 230 x 50 mm	1 item	42 - 55 mm	Yes	9079-51	- / 4
230 x 230 x 50 mm	1 item	50 - 75 mm	Yes	9079-52	- / 4
230 x 230 x 50 mm	1 item	75 - 90 mm	Yes	9079-53	- / 4
320 x 320 x 50 mm	1 item	100 - 110 mm	Yes	9079-54	- / 4

KAISER primer

KAISER primer is a high-quality, solvent-free coating which optimises adhesion for all KAISER sealing sleeves on absorbent, mineral surfaces, for example masonry, concrete, plasterboard or wood materials. The self-adhesive primer is water and heat resistant. It can also be used on Styrofoam, EPS or XPS etc.



Installation



The base must be dry and free of grease, oil and dust. Stir the primer thoroughly before working. Apply smoothly (apply twice to porous surfaces).



Before pressing the adhesive flange on, allow the primer to air until transparent. Thickened primer can be thinned with water.

KAISER primer

- The self-adhesive primer is water and heat resistant. It can also be used on Styrofoam, EPS, XPS etc.



Contents	250 ml
Art.-No.	9000-02
Inner packaging/shipping	- / 1



Sound insulation value R_w up to **77 dB**

Sound-insulation box

Sound insulation box for use in walls with increased demands on sound protection. The solid box body with additional sound insulation sheathing absorbs and reflects sound, which prevents disturbances in adjacent rooms. Sound insulation is the same as if no installation boxes were installed.

- Maintains the wall's sound insulation protection
- Also for retrofitting
- Installation up to 5-unit combinations
- Also for opposing installation
- Can be used with sound protection cover as a junction box



Examples of use



Example of installation of a switch/socket combination.

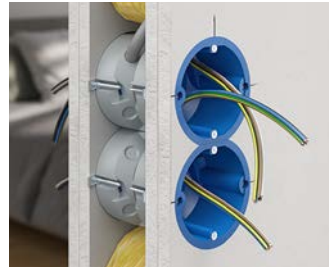

Use of an opposing sound insulation box.

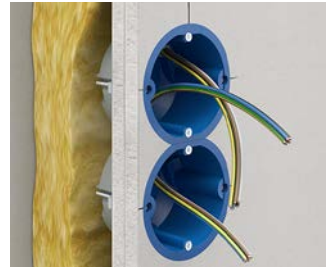

Use of a sound insulation box on one side of a double combination.

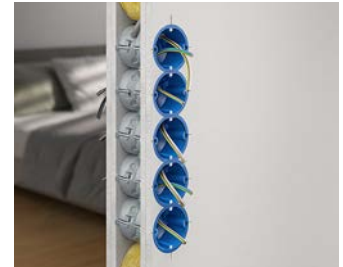

The sound insulation box can be used in up to five opposing combinations without weakening the sound insulation characteristics of the wall.

Comparison of sound insulation

Lightweight wall (2-shell, each triple-boarded) with sound insulation one-gang junction boxes.

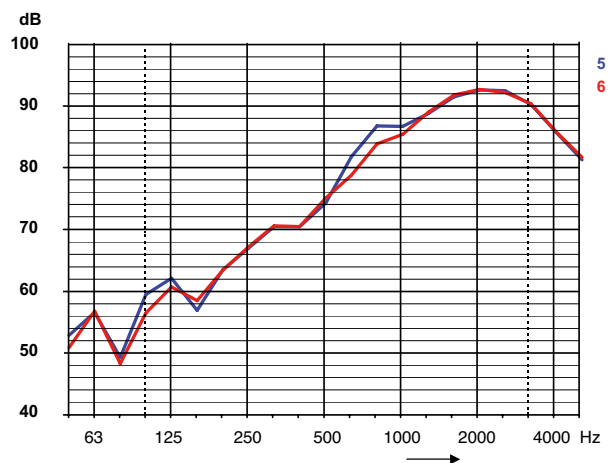
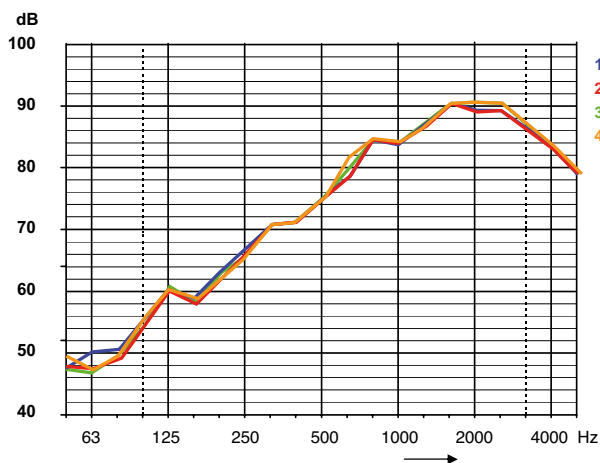

1 Wall, without installations, 77 dB | **2** Sound insulation box 9069-01, single, with accessory, 77 dB | **3** Sound insulation box 9069-01, single, with cover, 77 dB | **4** Sound insulation box 9069-01, 5-way, with accessory, 77 dB | **5** Wall, without installations, 78 dB | **6** with sound insulation electronics box, 9069-94, 78 dB

Sound-insulation box

- One-gang junction box for sound insulation walls in buildings
- Combination distance of 71 mm through single separation of the pre-embossed edge



Product-Data



3D animation

Depth	54,5 mm
For panel thickness	7 - 40 mm
Cut hole Ø	74 mm
Screw spacing	60 mm
Cable entries of up to Ø 11.5 mm	4
Support connectors for each package	5
for sound insulation walls up to	77 dB
Halogen-free	Yes
	Yes
Art.-No.	9069-01
Inner packaging/shipping	10 / 100

Sound insulation cover

- for sound insulation box
- Sound insulation function in conjunction with sound insulation box



Diameter	92 mm
Halogen-free	Yes
	Yes
Art.-No.	1184-69
Inner packaging/shipping	10 / 100

Support connector

- For fully insulated through-wiring in combinations
- for Art. No. 1555-21, 9069-01



Halogen-free	Yes
Art.-No.	9060-88
Inner packaging/shipping	25 / 100

FLUSH-MOUNTING

CAVITY WALL

CONCRETE

HOUSINGS

FIRE PROTECTION

PLUGGABLE

CONNECTIVITY

CABLE GLANDS

TOOLS

SERVICE

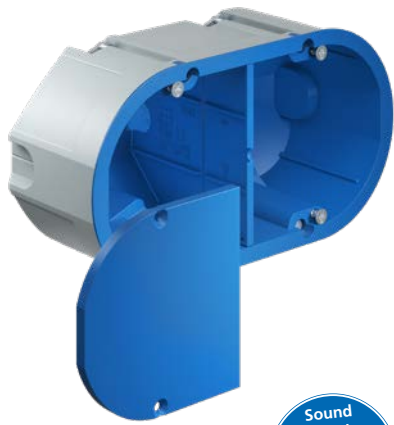

Sound insulation value R'_{w} up to **78 dB**

Sound insulation electronics box

Sound insulation electronics box for use in walls with increased demands on sound insulation. The sound insulation electronics box maintains the wall's sound insulation function and creates space for electronic switching devices, data boxes, cables and terminals. The electronics box makes possible population with cables and installation conduits up to M25.

- Maintains the wall's sound insulation protection
- Retrofitting is possible
- Also for use as a double box
- Extra-large terminal area for communications and network technology
- Additional space for electronic components (KNX actuators, relays, radio module, communications technology)



Examples of use



The electronics box provides space for all possible installations e.g. KNX actuators, Venetian blinds relays, alarm modules and many more.



Also ideal for network connections. The generous box volume offers sufficient space for cable reserves.



The electronics box can also be used as a double box, e.g. for switch and socket combinations.

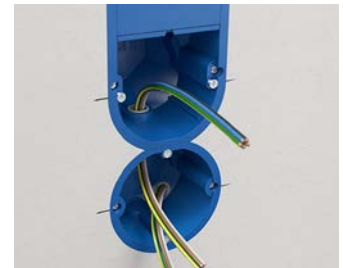

The electronics box can easily be combined with the sound insulation device junction box.

Sound insulation electronics box

- Electronics box for sound insulation walls in buildings
- Also for use as a double box
- For equipment inserts and electronic components
- Can be combined with each other and also with a sound insulation one-gang junction box



3D animation



Product-Data

Depth	70 mm
For panel thickness	7 - 40 mm
Cut hole Ø	2 x 74 mm
Screw spacing	60 mm
Centre distance	71 mm
Conduit entries for DIN EN conduits up to Ø 25 mm	4
Cable entries of up to Ø 11.5 mm for sound insulation walls up to	78 dB
Halogen-free	Yes
	Yes
Art.-No.	9069-94
Inner packaging/shipping	5 / 50

Sound-insulation box 68

Thanks to their solid box body in combination with the sound-absorbing surface on the base of the box, sound insulation 68 one-gang and one-gang junction boxes guarantee the wall's sound insulation. This function is completely maintained even with directly opposing installation. The easy opening process and the 68 mm installation opening ensure fast mounting and also easy retrofitting in existing electrical installations.

- Maintains the wall's sound insulation protection
- Also for retrofitting
- For Ø 68 mm installation openings
- For a directly opposing installation
- Easy entry for cables up to Ø 11.5 mm and conduits up to Ø M25

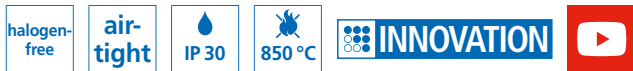

Sound insulation value R_w up to **69 dB**

Examples of use

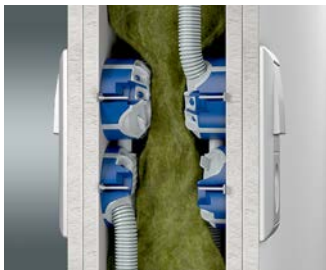

For sound insulation walls with a sound insulation value of up to 69 dB.



Also for directly opposing installation up to a 5-way combination.



Can be combined with one-gang and one-gang junction boxes.



With a sound insulation cover (Art. No. 1184-69), it can also be used as a junction box.

Comparison of sound insulation

Lightweight wall (2-layer, each triple-boarded)

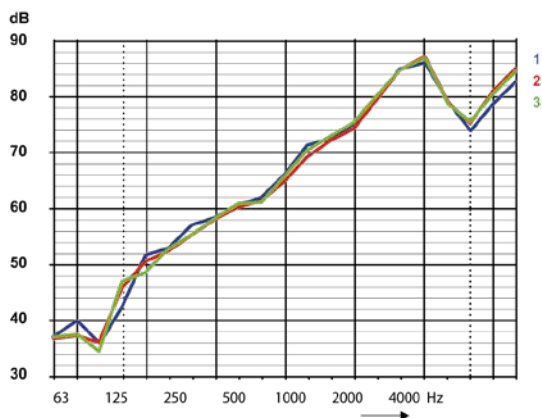

1 Wall, without installations, 69 dB. | **2** Sound insulation box 9069-03, single, with accessory, 69 dB. | **3** Sound insulation box 9069-04, single, with accessory, 69 dB. | **4** The solid box body and the sound-absorbing surface on the base of the box guarantee sound insulation up to 69 dB. | **5** Sound-absorbing strips on the box edge to reduce structure-borne sound. | **6** Easy opening of the conduit entry by means of pre-defined opening tab.

One-gang box sound insulation 68

- for sound insulation walls
- also for directly opposing installation
- minimum wall thickness 100 mm
- can be combined with each other and with the one-gang junction box





INNOVATION



3D animation



Product-Data

Depth	49 mm
Cut hole Ø	68 mm
Screw spacing	60 mm
Tube entries up to M25	2
Cable entries of up to Ø 11.5 mm	4
Support connectors for each package	5
For panel thicknesses up to	40 mm
for sound insulation walls up to	69 dB
Halogen-free	Yes
 / 	Yes / Yes
Art.-No.	9069-03
Inner packaging/shipping	10 / 100

One-gang junction box sound insulation 68

- for sound insulation walls
- also for directly opposing installation
- minimum wall thickness 125 mm
- combinable with each other and with the one-gang box





INNOVATION



3D animation



Product-Data

Depth	61 mm
Cut hole Ø	68 mm
Screw spacing	60 mm
Tube entries up to M25	2
Cable entries of up to Ø 11.5 mm	6
Support connectors for each package	5
For panel thicknesses up to	40 mm
for sound insulation walls up to	69 dB
Halogen-free	Yes
 / 	Yes / Yes
Art.-No.	9069-04
Inner packaging/shipping	10 / 100

Sound-insulation box 68 Flex

Thanks to its solid box body, in connection with the sound absorbing surface on the box base the Sound insulation 68 Flex electronics box guarantees the wall's sound insulation function. Additional insulating strips minimise body sound transfer via the component opening. Fast installation is ideal for modernising or extending existing systems. The flexible tunnel makes it easy to install, and creates space for electronic components, cable reserves and terminals.

- Maintains the wall's sound insulation protection
- For Ø 68 mm installation openings
- Additional sideway terminal compartment for communications and network technology
- Toolless cable and conduit entry
- Can be combined with support connectors, air-tight and fully-insulated



Sound insulation value R'_{w} up to **68 dB**



Examples of use

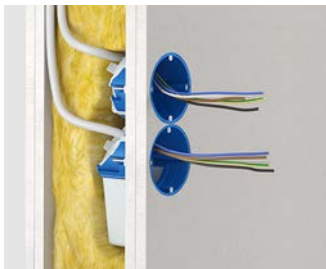

The combination with Sound insulation 68 one-gang and one-gang junction boxes is possible.



Additional space for connection terminals.



Accepts electronic components e.g. actuators.

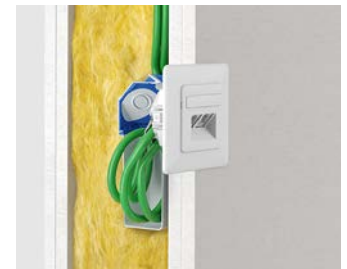

Space for cable reserves.

Sound-insulation box 68 Flex

- for sound insulation walls
- for accessories and electronic components
- Air-tight design with sealing membranes
- Elastic tunnel
- can be combined with sound insulation boxes 68





INNOVATION



3D animation



Product-Data

Length x Width x Depth	122 x 71 x 75 mm
For panel thickness	7 - 30 mm
Cut hole Ø	68 mm
Screw spacing	60 mm
Device screws +/-	2
Tube entries up to M25	2
Cable entries 3 x 2.5 mm ² or 5 x 1.5 mm ²	2
Cable entries 3 x 1.5 mm ²	2
Air-tight	Yes
for sound insulation walls up to	68 dB
Halogen-free	Yes
 / 	Yes / Yes
Art.-No.	9068-94
Inner packaging/shipping	10 / 100



NEW

Clean room one-gang junction box

With the new cleanroom appliance junction box, KAISER offers the ideal solution for reliably maintaining tightness in the cleanroom. The one-gang junction box, tested at the Steinbeis Transfer Centre STZ EURO in Offenburg in accordance with VDI 2083 Sheet 19 prevents the transmission of airborne particles, viruses or gases and has the highest tightness class (tightness class 7) of the clean room. Thanks to the sealing lip under the holding ring and the cable entries that can be created precisely using the KAISER universal opening cutter, an uncontrolled exchange of air can be permanently prevented to protect against contamination. The safe solution - even after the requalification test!

- For use in clean rooms in a medical environment or in hygienic areas
- To protect personnel and products in cleanrooms from contamination of any kind (airborne particles, viruses or gases)
- For \varnothing 68 mm installation openings
- Complete assembly and installation with just one screwdriver



Processing instructions



Fully insulated through-wiring at the normative centre distance of 71 mm by means of support connectors (Art. No. 9060-78).



Up to 6 cable entries for sheathed cables with outer diameter up to max. \varnothing 11.5 mm.



Integrated cable retention of the NYM cables according to EN 60670.



The peripheral sealing lip prevents the exchange of air and airborne particles at the installation opening.

Installation



Create installation opening \varnothing 68 mm with KAISER cutter (e.g. EXPERT, Art. No. 1082-30).



Produce the precisely fitting cable entry (max. up to \varnothing 11.5 mm) using KAISER universal opening cutter (Art. No. 1085-80).



Insert the cables through the elastic sealing membrane and tighten the screws.



Secure the installation accessory with the device screws.

Verifications

Guaranteed safe maintenance of tightness in the cleanroom - with certificate.



Clean room one-gang junction box

NEW

INNOVATION

- For professional installation in clean room walls and functioning containments
- Certified according to VDI 2083 sheet 19 (tightness class 7, extended class 11)
- Airtight design with sealing membranes and peripheral sealing lip
- For cables up to max. Ø 11.5mm with integrated cable retention



Depth	62 mm
For panel thickness	7 - 40 mm
Cut hole Ø	68 mm
Screw spacing	60 mm
Cable entries of up to Ø 11.5 mm	6
Air-tight	Yes
Art.-No.	9264-32
Inner packaging/shipping	10 / 100



Safety for X-ray rooms. One-gang junction box for radiation protection walls.

KAISER's innovative radiation protection box protects against radiation used for medical purposes, e.g. in X-ray facilities. The high density of the radiation protection compound absorbs soft and hard X-rays. The box is especially suitable for lead-free radiation protection walls (e.g. Knauf Safeboard) and - because of its dose-reducing effect in the tube voltage range between 40 - 150 kV - guarantees a lead-equivalent value for the wall of up to 3 mm Pb even with opposing installation. In addition, the box can easily be used in lead-lined walls. In this case, the radiation protection box achieves a lead-equivalent value of 1.5 mm Pb with walls which are leadlined on one side.

- Protection against X-rays
- Suitable for lead-free radiation protection walls
- Lead-free - no health risks
- Retrofitting is possible
- Fast installation without additional screening measures
- Opposing installation is possible
- Maintains the wall's sound insulation protection



Examples of use



Example of installation of a switch/socket combination.



Installation of the radiation protection box in the wall.

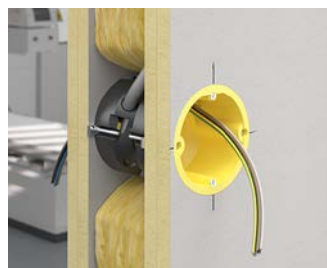

Opposing use of the radiation protection box.



Use of the radiation protection box in a triple combination.

Allocation table for universal opening cutters



Cavity wall installation for radiation protection boxes		Ø setting
NYM cable	3 x 1.5 mm ²	9.5
	5 x 1.5 mm ²	10.5
	3 x 2.5 mm ²	9.5
Support connector	9060-74	Cut up to the marking of the connector entry

You can create cable entries with the specified strain relief easily and to the exact required size with the universal opening cutter (Art. No. 1085-80).

Radiation protection one-gang junction box

- One-gang junction box for radiation protection boxes in buildings
- Combination distance of 71 mm through single separation of the pre-embossed edge



3D animation



Product-Data

Depth	58,5 mm
For panel thickness	7 - 40 mm
Cut hole Ø	74 mm
Screw spacing	60 mm
Cable entries of up to Ø 11.5 mm	2
Support connectors for each package	3
Lead-free	Yes
Lead equivalent value [mm Pb]	bis 3
Halogen-free	Yes
	Yes
Art.-No.	9074-01
Inner packaging/shipping	5 / 10

Support connector

- For fully insulated through-wiring in combinations
- for Art. No. 9074-01



Art.-No.	9060-74
Inner packaging/shipping	25 / 100



Radiation protection one-gang junction box for lead-lined radiation protection walls.

The KAISER radiation protection box for use in lead-lined walls protects against radiation used for medical purposes, e.g. in X-ray equipment. The radiation protection material with an integrated lead function component absorbs the dangerous X-ray radiation with a lead equivalent value of 2,5 mm Pb as effectively as 2,5 mm thick lead.

- Protection against X-rays
- For lead-lined radiation protection walls
- No health risks - no skin contact with lead function component
- Retrofitting is possible
- Fast installation without additional screening measures
- Maintains the wall's sound insulation protection



Examples of use



Example of installation of a switch/socket combination.



Using the radiation protection box in the wall.

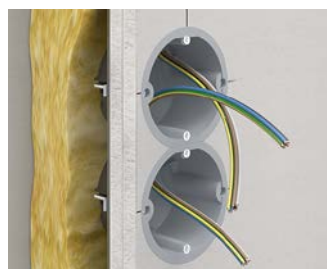

Single-side use of the radiation protection box in a double combination.



Fitting a triple combination is also easy.



Cavity wall installation for radiation protection boxes	Ø setting	HSS drill Ø
NYM cable	3 x 1,5 mm ²	9,5
	5 x 1,5 mm ²	9,5
	3 x 2,5 mm ²	9,5
	5 x 2,5 mm ²	Connector
Support connector	9060-88	Cut up to the marking of the connector entry.

Making an exact-fitting cable entry with the specified cable retention is easy - just use an HSS drill together with the universal opening cutter (Art. No. 1085-80).

The matching drills and universal opening cutter settings are shown in the tables.

Radiation protection one-gang junction box

- One-gang junction box for lead-lined radiation protection walls in buildings
- Combination distance of 71 mm through single separation of the pre-embossed edge



3D animation



Product-Data

Depth	58,5 mm
For panel thickness	7 - 40 mm
Cut hole Ø	74 mm
Screw spacing	60 mm
Cable entries of up to Ø 11.5 mm	2
Support connectors for each package	3
Lead equivalent value [mm Pb]	2,5
Halogen-free	Yes
 VDE	Yes
Art.-No.	9074-03
Inner packaging/shipping	5 / 10

Support connector

- For fully insulated through-wiring in combinations
- For Art. Nos. 1159-90, 1555-51, 9069-03, 9069-04 and 9074-03



Art.-No.	9060-88
Inner packaging/shipping	25 / 100

Screened one-gang junction box



Screened one-gang junction box for cavity wall installation. The conductive coating suppresses interference with a high alternating field component, whether radiated or received.

- For environmentally-safe electrical installation, biological construction
- With screening and potential conductivity
- The functional earth of the box must only be connected to the potential equalisation and not to the equipment grounding conductor (PE conductor)



Installation



Remove cable sheath and screen with AMZ 2 (Art. No. 1190-02). Fit bare tracer wire with transparent insulating hose.

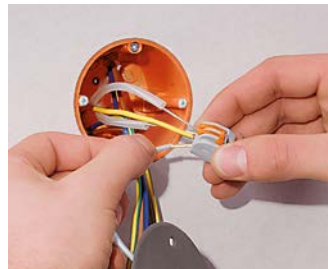

Connect functional earth of the box to tracer wires of screened cable.



As a junction box, connect the box cover's functional earth to the tracer wires of the cables.



Attach cover to box with device screws.

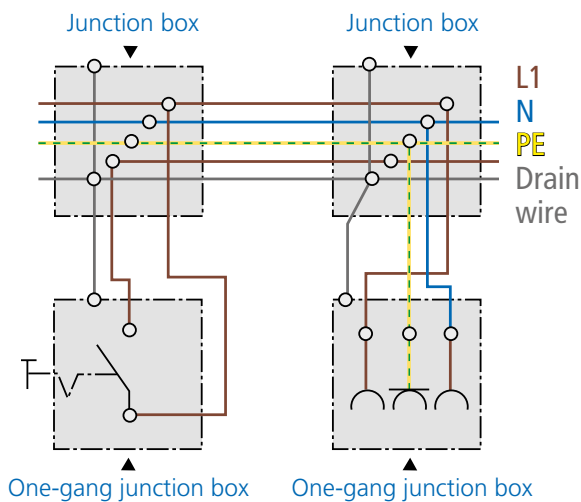

Technical processing instructions/standards

- dimensions in accordance with German DIN 49073
- for rooms used for medical purposes, environmentally-friendly construction, etc.
- the conductive coating suppresses interference with a high alternating field component, whether radiated or received
- The functional earth of the box must only be connected to the potential equalisation and not to the equipment grounding conductor (PE conductor)
- Not suitable for use in X-ray or radiation rooms!

Screened one-gang box / one-gang junction box

- with screening and potential downlead



Depth	47 mm	61 mm	68 mm
For panel thickness	7 - 40 mm	0,2 - 40 mm	7 - 40 mm
Cut hole Ø	68 mm	68 mm	68 mm
Screw spacing	60 mm	60 mm	60 mm
Device screws	2	2	2
Break-out openings Ø 20 mm	2	4	4
Cable entries 3 x 2.5 mm ² or 5 x 1.5 mm ²	2	2	2
Cable entries 3 x 1.5 mm ²	2	4	4
Cable entries for low voltages	2	2	2
Art.-No.	9063-88	9068-88	9064-88
Inner packaging/shipping	10 / 100	10 / 100	10 / 100

Screened cover

- for making screened one-gang junction boxes
- for one-gang junction boxes Art. No. 9064-88 and Art. No. 1555-88



Diameter	80 mm
Screw spacing	60 mm
Art.-No.	1164-88
Inner packaging/shipping	10 / 100

Screened junction casing

- for cavity wall and flush-mounting installation
- with screened cover
- With Ø 3.2 x 15 mm cover screws
- Protection class IP 3X



Length x Width x Depth	107 x 107 x 53 mm
Cut hole Ø	4 x 35 mm
Break-out openings Ø 20 mm	8
Cable entries for NYM and low-voltage cabling	Yes
For terminals up to	4 mm ²
Art.-No.	9195-88
Inner packaging/shipping	1 / 10

Note

Other installation boxes/housings with screening available on request. Please use our radiation protection box in X-ray areas or areas with ionising radiation.



NEW

Damp room one-gang junction box

The new damp room one-gang junction box from KAISER provides optimum sealing for electrical installations in areas exposed to splash water, process water and cleaning water. Thanks to the 5 cm peripheral adhesive collar, the innovative, DIN 18534-tested and certified waterproof one-gang junction box can be easily integrated into the sealing layer (e.g. sealing slurry or sealing membranes) and maintains the protection target of the wall. Uncontrolled moisture exchange is permanently prevented thanks to the precisely fitting cable entries created using the KAISER universal opening cutter.

- For professional installation in sealed interior rooms, such as commercial kitchens, bathroom modules or damp rooms in hospitals
- Tested and certified watertightness in accordance with DIN 18534
- For installation openings \varnothing 68 mm
- Six air-tight and watertight cable entries
- Device screws with plus-minus drive



Application examples

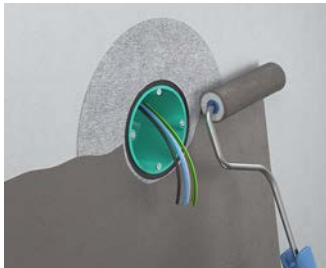

The fleece-like structure of the peripheral adhesive collar enables problem-free sealing in sealing slurries...



...or conventional sealing membranes and thus fits seamlessly into the existing sealing system.



Waterproof one-gang junction box, mounted in a cement fibreboard, integrated into the sealing level with attached tiling.



To comply with the IP protection class, the plaster compensation ring (Art. No. 9155-61 or -62) can be fitted for > 10 mm wall coverings.

Processing instructions



Produce the exact fitting cable entry using KAISER universal opening cutter (Art. No. 1085-80).



Up to six cable entries for sheathed cables with external diameter up to max. \varnothing 11.5 mm.



By removing the backing film, the peripheral collar can be easily stuck to the wall surface.



Integrated cable retention of NYM cables according to DIN EN 60670.

Installation

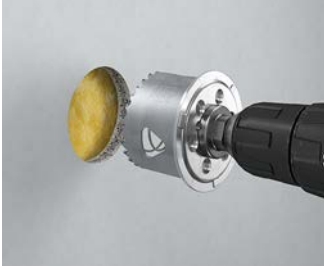

Create the exact installation opening \varnothing 68 mm using the KAISER cutter EXPERT (Art. No. 1082-30).



Open the cable entries using the KAISER universal opening cutter (Art. No. 1085-99) and insert the cables up to \varnothing 11.5 mm.



Gradually remove the backing film, align the box in the installation opening and then spread the sleeve to bonding it to the wall surface.



Fastening of the box in the installation opening by means of lug fixing.

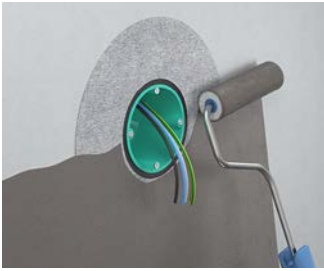

Application of the water-proofing layer (e.g. sealing slurry).



Application of the wall covering (e.g. tiling).



Fasten the installation accessory using the device screws.



To comply with the IP protection class, the plaster compensation ring (Art. No. 9155-61 or -62) can be fitted for $>$ 10 mm wall coverings.

Damp room one-gang junction box

NEW

INNOVATION

- Peripheral 5 cm wide adhesive collar to hold mineral sealing materials, e.g. sealing slurries
- Convenient sealing into the sealing layer thanks to the fleece-like surface structure of the sealing sleeve
- Tested and certified according to DIN 18534
- Air-tight and watertight design with sealing membranes for six cables up to max. \varnothing 11.5 mm with integrated cable retention
- Can be used with the KAISER plaster compensating rings (Art. No. 9155-61 or -62) with built-up wall coverings



Depth	62 mm
For panel thickness	7 - 40 mm
Cut hole \varnothing	68 mm
Screw spacing	60 mm
Cable entries of up to \varnothing 11.5 mm	6
Air-tight	Yes
Watertight acc. to DIN 18534	Yes
Art.-No.	9264-42
Inner packaging/shipping	10 / 100

Junction box, Accessories

for cavity wall installation

Screws

- for one-gang boxes and one-gang boxes for cavity walls
- for the following articles: 9062-.., 9063-.., 9064-.., 9066-.., 9067-01, 9068-.., 9071-.., 9073-.., 9075-.., 9192-.., 9195-.., 9196-.., 9197-.., 9248-.., 9300-.., 9098-77, 9263-.., 9264-..



Length	44,5 mm
Screws Ø	3 mm
Art.-No.	2445-25
Inner packaging/shipping	100 / 2000

Metal lugs for screws

- for one-gang boxes and one-gang boxes for cavity walls
- for the following articles: 9061-.., 9062-.., 9063-.., 9064-.., 9066-.., 9067-01, 9068-.., 9071-.., 9073-.., 9075-.., 9148-00, 9195-.., 9248-.., 9300-.., 9098-77, 9263-.., 9264-..



Length x Width	7 x 13 mm
Art.-No.	2445-50
Inner packaging/shipping	100 / 2000

Device screws +/-

- self-tapping Ø 3.2 mm
- Countersunk head with PZ1/S combination drive
- surface double-treated
- corrosion-resistant in accordance with German DIN VDE standard



Length	15 mm	20 mm	25 mm	40 mm
Art.-No.	2472-15	2472-20	2472-25	2472-40
Inner packaging/shipping	100 / 10000	100 / 10000	100 / 10000	100 / 10000

Sealing screws

- in pure brass
- self-tapping Ø 3.2 mm
- with cross-hole in the screw head through which sealing wire can be pulled



Length	15 mm	40 mm
Art.-No.	2444-15	2444-40
Inner packaging/shipping	100 / 1000	100 / 1000

Junction casings and boxes

Junction casings in all sizes and for almost any kind of installations. This product range features practical housing sizes as well as a robust housing design which is perfect for building sites.

- As central junction casings for star-shaped cable laying
- Easy to rewire when changing the way rooms are used
- With separator walls for safe separation of electrical circuits
- Create precise wall openings using the drilling template supplied
- End cover with screw fastening for VDE-compliant installation



Installation



Stick drilling template (supplied) to wall. Open four corners with cutter. Cut out edges with cutter or fretsaw.



Cut out intermediate parts with cutter or fretsaw.



Break out pre-cut holes, feed in cables, insert casing and attach with the FX⁴-screws.



Fasten inserted box or casing with FX⁴ fast screw attachment.

Junction casing

- for installation: DIN terminal strips, TS 35 standard rails for terminal strips, etc., terminal blocks up to 16 mm²
- with drilling template (supplied)
- including cover



Length x Width x Depth	105 x 105 x 53 mm	105 x 105 x 53 mm	165 x 165 x 72 mm	165 x 165 x 72 mm
Cut hole Ø	4 x 35 mm	4 x 35 mm	4 x 68 mm	4 x 68 mm
with 4 screw domes	Yes	Yes	-	-
Break-out openings Ø 20 mm	8	8	8	8
Cable entries for NYM and low-voltage cabling	Yes	Yes	Yes	Yes
For terminals up to	4 mm ²	4 mm ²	16 mm ²	16 mm ²
use separator wall for maximum of 2 electrical circuits	Yes	Yes	Yes	Yes
Halogen-free	-	Yes	-	Yes
Break-out openings Ø 25 mm	-	-	2	2
Break-out openings Ø 32 mm	-	-	2	2
VDE / OVE	Yes / Yes	Yes / Yes	Yes / Yes	Yes
Art.-No.	9195-91	9195-77	9196-91	9196-77
Inner packaging/shipping	- / 10	- / 10	- / 10	- / 10



Junction casings

for cavity wall installation

Junction casing

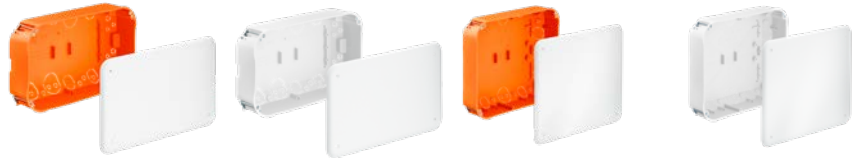
- for installation: DIN terminal strips, TS 35 standard rails for terminal strips, etc., terminal blocks up to 16 mm²
- with drilling template (supplied)
- including cover



Length x Width x Depth	240 x 140 x 72 mm	240 x 140 x 72 mm	235 x 205 x 72 mm	235 x 205 x 72 mm
Cut hole Ø	4 x 68 mm	4 x 68 mm	4 x 68 mm	4 x 68 mm
Break-out openings Ø 20 mm	8	8	8	8
Break-out openings Ø 25 mm	2	2	2	2
Break-out openings Ø 32 mm	2	2	2	2
Cable entries for NYM and low-voltage cabling	Yes	Yes	Yes	Yes
For terminals up to	16 mm ²	16 mm ²	16 mm ²	16 mm ²
Maximum of 3 electrical circuits with separator walls	Yes	Yes	Yes	Yes
Halogen-free	-	Yes	-	Yes
 / 	Yes / Yes	Yes	Yes / Yes	Yes / Yes
Art.-No.	9192-91	9192-77	9197-91	9197-77
Inner packaging/shipping	- / 10	- / 10	- / 10	- / 10

Junction box Ø 120 mm

- receptacle for TS 35 standard rail
- Make cut hole with Variocut 1089-00 in fully extended position or bi-metallic cutter 1082-20
- including cover



Depth	65 mm	65 mm
Cut hole Ø	120 mm	120 mm
Break-out openings Ø 20 mm	4	4
Break-out openings Ø 25 mm	2	2
Cable entries for NYM and low-voltage cabling	Yes	Yes
For terminals up to	4 mm ²	4 mm ²
For max. 2 electrical circuits through separator wall Art. No. 9073-20	Yes	Yes
Halogen-free	-	Yes
	Yes	Yes
Art.-No.	9073-01	9073-78
Inner packaging/shipping	- / 10	- / 10

Potential equalisation casing 10²

- for bathrooms or similar
- with potential equalisation rail, protected against corrosion
- with 4 screw domes
- With Ø 3.2 x 15 mm cover screws
- including cover



Length x Width x Depth	105 x 105 x 53 mm
Cut hole Ø	4 x 35 mm
Connections for 6–16 ² circular conductors (also uncut)	1
Connections for 1.5–10 ² cables	6
Art.-No.	9195-73
Inner packaging/shipping	1 / 10

Note

Other earthing products can be found at our website.

Replacement cover

- flat cover edge
- surface roughened
- countersunk for screw heads



For casing size - cavity wall boxes	105 x 105 mm	165 x 165 mm	238 x 142 mm	235 x 205 mm
For casing size - concrete construction boxes	128 x 128 mm	180 x 180 mm	-	250 x 220 mm
For casing size - flush-mounting boxes	107 x 107 mm	159 x 159 mm	240 x 142 mm	238 x 208 mm
Fireproof	850 °C	850 °C	850 °C	850 °C
Art.-No.	1095-93	1096-93	1092-93	1097-93
Inner packaging/shipping	10 / 500	10 / 200	5 / -	5 / 100

Replacement cover for junction boxes Ø 120 mm

- flat cover edge
- surface roughened
- countersunk for screw heads



For Art. No.	9073-01/-91	9073-78/-77
Halogen-free	-	Yes
Art.-No.	9073-93	9073-79
Inner packaging/shipping	10 / -	10 / -

Junction casings

for cavity wall installation

Separator walls

- to separate electrical circuits



for casing size	105 x 105 mm	165 x 165 mm	240 x 140 mm	235 x 205 mm
Art.-No.	9195-20	9196-20	9192-20	9197-20
Inner packaging/shipping	10 / -	10 / 10	10 / 10	10 / -

Separator wall

- to separate electrical circuits
- for junction boxes Ø 120 mm



Art.-No.	9073-20
Inner packaging/shipping	10 / -

Universal installation housings

Universal installation housings for a wide range of device installations always ensure optimum space for all kinds of devices. The intelligent housing design ensures stability and a secure fit in the wall.

- For displays, LED lights and much more
- For installing almost all shapes and sizes
- Mineral fibreboard allows individual installation opening
- With FX⁴ quick assembly technology



Installation



Mark installation opening and cut with a fretsaw.



Insert cables or conduits, feed housing into wall and install with FX⁴-quick-assembly technology.



Lightly smooth edges with filler (use plastic-based filler).



Cover with wallpaper etc. and install the required device.

Mounting instructions



Use only screws that go into but not through the mineral fibreboard when attaching the device (e.g. SPAX countersunk head screw 3.5 x 15 mm)!

Note

Observe the maximum stroke length of the saw blade when sawing the installation opening.

Universal installation housings

for cavity wall installation

Universal installation housing with mineral fibreboard

- with mineral fibreboard for cutting out individual installation holes
- with drilling template (supplied)
- all-round groove indicates the maximum opening size



Length x Width x Depth	105 x 105 x 53 mm	105 x 105 x 53 mm	165 x 165 x 72 mm	165 x 165 x 72 mm
Cut hole Ø	4 x 35 mm	4 x 35 mm	4 x 68 mm	4 x 68 mm
maximum opening size	70 x 70 mm	70 x 70 mm	110 x 110 mm	110 x 110 mm
For devices with an installation depth of max.	40 mm	40 mm	50 mm	50 mm
Break-out openings Ø 20 mm	8	8	8	8
Cable entries for NYM and low-voltage cabling	Yes	Yes	Yes	Yes
Halogen-free	-	Yes	-	Yes
Break-out openings Ø 25 mm	-	-	2	2
Break-out openings Ø 32 mm	-	-	2	2
Art.-No.	9195-22	9195-27	9196-22	9196-27
Inner packaging/shipping	- / 10	- / 10	- / 10	- / 10

Universal installation housing with mineral fibreboard

- with mineral fibreboard for cutting out individual installation holes
- with drilling template (supplied)
- all-round groove indicates the maximum opening size



Length x Width x Depth	240 x 140 x 72 mm	240 x 140 x 72 mm	235 x 205 x 72 mm	235 x 205 x 72 mm
Cut hole Ø	4 x 68 mm	4 x 68 mm	4 x 68 mm	4 x 68 mm
maximum opening size	170 x 105 mm	170 x 105 mm	190 x 150 mm	190 x 150 mm
For devices with an installation depth of max.	55 mm	55 mm	50 mm	50 mm
Break-out openings Ø 20 mm	8	8	8	8
Break-out openings Ø 25 mm	2	2	2	2
Break-out openings Ø 32 mm	2	2	2	2
Cable entries for NYM and low-voltage cabling	Yes	Yes	Yes	Yes
Halogen-free	-	Yes	-	Yes
Art.-No.	9192-22	9192-27	9197-22	9197-27
Inner packaging/shipping	- / 10	- / 10	- / 10	- / 10

International products

For international projects, we offer a large range of products which meet the relevant national standards and regulations.

- Dimensions and approvals based on national standards
- Suitable installation tools
- Many combination options



FLUSH-MOUNTING

CAVITY WALL

CONCRETE

HOUSINGS

FIRE PROTECTION

PLUGGABLE

CONNECTIVITY

CABLE GLANDS

TOOLS

SERVICE

Quickbox® cavity wall



- compatible with Feller SNAPFIX®
- for plate thickness 7 - 35 mm
- indispensable in light and column construction
- Retrofitting is possible
- Extremely robust construction
- For device screws Ø 3 mm
- Max. tightening torque 0.5 Nm



Length x Width x Depth	83 x 83 x 65 mm	145 x 83 x 65 mm	205 x 83 x 65 mm
Cut hole Ø	83 mm	83 mm	83 mm
Conduit entries M20	4	6	8
Conduit entries M25	4	6	8
Combination	1x1	2x1	3x1
850 °C /	Yes / Yes	Yes / Yes	Yes / Yes
/	Yes / Yes	Yes / Yes	Yes / Yes
Art.-No.	9098-77	9098-77.02	9098-77.03
Inner packaging/shipping	20 / 100	- / 50	- / 10

Quickbox® cavity wall



- for plate thickness 7 - 35 mm
- indispensable in light and column construction
- Retrofitting is possible
- Extremely robust construction
- For device screws Ø 3 mm
- Max. tightening torque 0.5 Nm



Length x Width x Depth	145 x 145 x 65 mm	205 x 145 x 65 mm
Combination	2x2	3x2
Cut hole Ø	83 mm	83 mm
Conduit entries M20	8	10
Conduit entries M25	8	10
850 °C /	Yes / Yes	Yes / Yes
/	Yes / Yes	Yes / Yes
Art.-No.	9098-77.04	9098-77.06
Inner packaging/shipping	- / 10	- / 5

Quickbox® ECON Pro

NEW



- compatible with Feller SNAPFIX®
- Airtight design with sealing membranes
- Toolless pipe inlets
- M20 & M25 Pipe Inlets
- No shadow gaps of the covers
- Pipe inlet 90° swivelling



Length x Width x Depth	83 x 83 x 68 mm	145 x 83 x 68 mm	205 x 83 x 68 mm
Cut hole Ø	83 mm	83 mm	83 mm
Conduit entries M20	2	3	4
Conduit entries M25	2	3	4
Combination	1x1	2x1	3x1
/	Yes / Yes	Yes / Yes	Yes / Yes
Art.-No.	9299-77	9299-77.02	9299-77.03
Inner packaging/shipping	20 / 100	- / 50	- / 10

BASIC cutter

NEW



- with holder and centring drill
- fits all electric drills with 13 mm chuck



Cut hole Ø	83 mm
Depth of cutting hole	32 mm
For Quickbox Ø 83 mm	Yes
Art.-No.	1084-83
Inner packaging/shipping	- / 10

Sound insulation box for Swiss accessory combinations



- compatible with Feller SNAPFIX®
- One-gang boxes for sound insulation walls in buildings
- Maintains the wall's sound insulation protection
- also for opposing installation
- for plate thickness >10 - 40 mm
- For device screws Ø 3 mm
- Max. tightening torque 0.5 Nm



Length x Width x Depth	83 x 83 x 50 mm	145 x 83 x 50 mm	205 x 83 x 50 mm
Combination	1x1	2x1	3x1
Drill Ø	83 mm	83 mm	83 mm
/	Yes / Yes	Yes / Yes	Yes / Yes
/	Yes / Yes	Yes / Yes	Yes / Yes
Art.-No.	9798-77	9798-77.02	9798-77.03
Inner packaging/shipping	10 / 100	- / 5	- / 5

Sound insulation box for Swiss accessory combinations



- compatible with Feller SNAPFIX®
- One-gang boxes for sound insulation walls in buildings
- Maintains the wall's sound insulation protection
- also for opposing installation
- for plate thickness >10 - 40 mm
- For device screws Ø 3 mm
- Max. tightening torque 0.5 Nm
- Pipes must be sealed with sealing plugs on both sides of the pipes!



Length x Width x Depth	83 x 83 x 73.5 mm	145 x 83 x 73.5 mm	205 x 83 x 73.5 mm
Combination	1x1	2x1	3x1
Cut hole Ø	83 mm	83 mm	83 mm
Tube entries up to M25	2	2	2
	Yes	Yes	Yes
Art.-No.	9799-77	9799-77.02	9799-77.03
Inner packaging/shipping	10 / 100	- / 5	- / 5

Halogen-free cavity wall boxes/fire resistance

All KAISER boxes and casings for cavity wall mounting as well as several accessory parts are available as halogen-free products.

- Fire-resistant up to 850°C.
- Heat-resistant up to 105°C.
- Electrically well-insulated, shock and pressure-resistant.
- There are no chemical reactions which cause the oxygen to be bound.
- No corrosive substances such as hydrochloric acid gas or hydrogen bromide are released.



The identifying feature of these products is that they are available in white.

Cavity wall boxes and casings with the VDE symbol have been tested for fire resistance in a glow wire test at 850°C in accordance with VDE 0471/DIN EN 60695-2-11. This test must demonstrate that a fire cannot start in the cavity wall boxes if a fault occurs in the electrical installation. In addition, always ensure compliance with the current fire prevention measures for wall constructions.

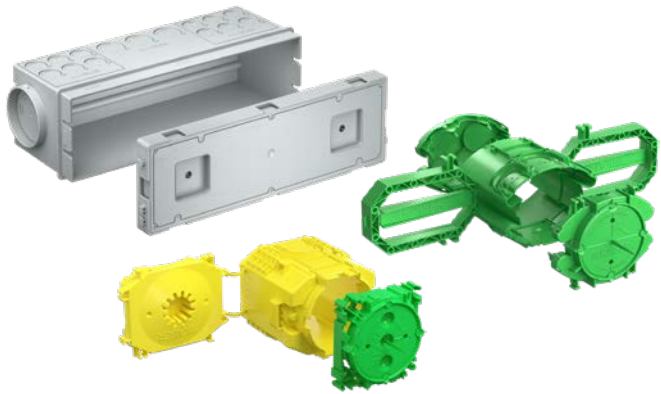

On-site mixed concrete

- Complete systems for on-site mixed concrete B¹
- Sophisticated colour system for easy assignment of system components
- Prefix® installation technology for simple, fast installation against the opposing formwork without a support element
- Central transition casings for feeding in electrical circuit distributors
- Wide range of fastening options on the formwork



International

- International products for accessory installation according to country-specific standards and requirements



Cable routing, conduit feeding and sealing systems



- Practical solutions for wall-ceiling transitions
- Safe, visible and certified protection through the use of KAISER sealing systems for cables and conduits, as well as cable and conduit bundles





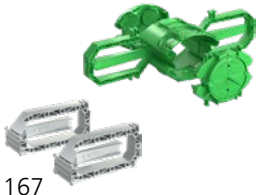

Tools

- Professional system tools for fast, safe installation
- Extensive system accessories

see chapter **TOOLS**
from page 376

	On-site mixed concrete B¹ Fixing to the working formwork	Prefix® for fastening to the reinforcement	International Installation of international accessories
		 pg. 167	
For installation accessories			
One-gang boxes	pg. 161	-	pg. 200
One-gang junction boxes	pg. 161	pg. 175	pg. 200
Large conduit boxes	pg. 162	-	-
Perilex® one-gang boxes	pg. 164	-	-
CEE one-gang boxes	pg. 164	-	-
Electronics box	pg. 166	-	-
Two-gang junction box	pg. 166	-	-
Universal installation housings	pg. 197	-	-
For cable outlets			
Wall light connection	pg. 162	pg. 175	-
Luminaire connection	pg. 178	-	-
Luminaire installation and connection	pg. 177	-	-
For cable connections			
Junction boxes	pg. 164	-	-
Junction casings	pg. 168/201	-	pg. 200
Potential equalisation casing	pg. 169	-	-
Accessories			
Fixing	pg. 167/187	pg. 167	pg. 167/187
Support element	pg. 173	-	pg. 173
Sealing of electrical installation conduits (air-tight and smokeproof)	pg. 33/117/302	pg. 33/117/302	-
Plaster compensation	-	-	-
End cover	pg. 205	-	-

Cable and conduit entry systems | Product overview

	Transitions	Exits	Conduit supports	Central transition casing	Sealings in fire protection ceilings and walls
	 pg. 184	 pg. 188	 pg. 189	 pg. 190	 pg. 295
Conduit sizes					
Ø 20 mm	•	•	•	•	•
Ø 25 mm	•	•	•	•	•
Ø 32 mm	•	•	•	•	•
Ø 40 mm	•	•	•	•	•
Ø 50 mm	-	-	-	•	•
Ø 63 mm	-	-	-	•	•
Cables / cable bundles	-	-	-	-	•

Production methods for on-site mixed concrete



Concrete walls can be manufactured in upright (vertical) or flat (horizontal) formwork. Horizontal formwork has only one formwork side, while vertical formwork has two formwork sides: the working formwork and the opposing formwork.



Free-standing reinforcement is always used when formwork elements are still installed in other places and can only be set up later on.



Sliding or travelling formwork is used vertically for the production of structures with great heights and horizontally, e.g. for roadway pavements and concrete safety barriers.



The slow sliding or travelling of the formwork ensures a steady construction progress.

Installation in on-site mixed concrete

The KAISER concrete construction system for all concreting methods and types of construction. It offers an extensive programme with numerous wall and ceiling boxes as well as practical solutions for wall to ceiling transitions.



1 HaloX® 100 Multi-conduit entry | **2** B¹ universal ceiling exit | **3** HaloX® 250 with tunnel 325 for on-site mixed concrete, HaloX® 250 universal front part | **4** Formwork protection | **5** B¹ device connection socket | **6** HaloX® 100 for on-site mixed concrete, HaloX® 100 front part, square | **7** B¹ ceiling junction box | **8** HaloX® 180 with tunnel 190 for on-site mixed concrete, HaloX® 180 facing concrete front part | **9** B¹ large conduit one-gang junction box, B¹ Prefix® system wing set | **10** B¹ device connection socket | **11** Prefix® concrete building box | **12** Wall and ceiling transition 30°, B¹ Prefix® system wing set, B¹ Prefix® wall exit adapter Ø 25 mm | **13** Potential equalisation casing 16²

The KAISER colour system.

The different colours of the individual components make correct installations easier.

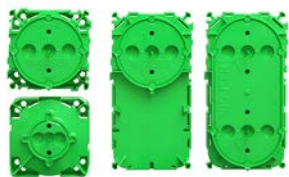

Green: Front parts for fixing to the formwork.



Yellow: Box and casing rear parts for wall installation.



Red: Box rear parts for ceiling installation.



Grey: Intermediate parts and attachment accessories.

Ways of attaching to various types of formwork

Product description	For wood formwork			For steel formwork				
	Nail Ø 2 mm	Wood screw Ø 4 mm	M6 threaded dowel	Expanding dowel	Magnet	Adhesive foil	M6 weld-on screw	Hot glue
Wall and ceiling box	•	•	•	•	•		•	•
Boxes*	•	•	•	•		•	•	•
Bushes	•	•						•
transitions	•	•						•
Abutment	•	•	•	•		•	•	•
Ceiling strips	•	•						•
Conduit and cable distance spacer	•	•	•	•				•

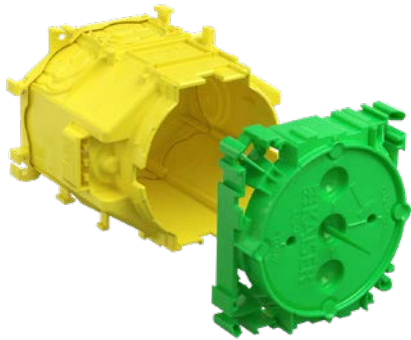

B¹ one-gang box and B¹ one-gang junction boxes

B¹, the new on-site mixed concrete range of products for electrical installation work. In addition to the tried-and-tested system features such as the flat front part, sturdy fixing domes and the support element slot with a sprung box base, the new B¹ range has innovative conduit entries, sturdy slots for the new B¹ Prefix[®] system wing range, and also bridges – which can be broken out later if required – for connecting accessories in combinations.

- Suitable for all types of formwork
- Slot for B¹ Prefix[®] system wing set
- Can be stably combined over the complete box body with a standardised combination distance of 71 mm
- Innovative conduit entries for fast processing on the construction site
- Signal bristles for easy location with installations on the opposing formwork side
- Larger mounting and installation space
- Installation of pre-wired installation accessories with multiple combinations, because the bridge can be broken out later

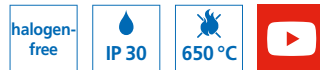

Fixing and alignment of the front part



Exact alignment by centre marking.



Fixing by means of steel nails.

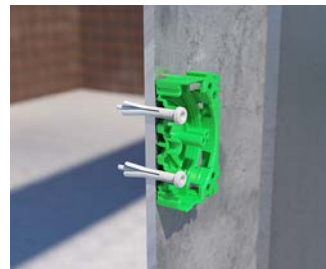

Fixing by means of KAISER expanding dowels (Art. No. 1217-02).



Fixing by means of threaded dowels.

Combination in accordance with DIN

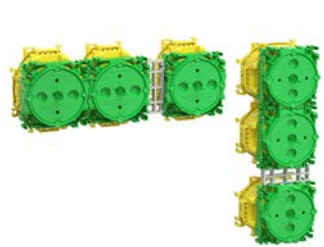

For multiple combinations, many of the B¹ wall applications can be combined in two directions at a standard combination distance of 71 mm (DIN 49075).

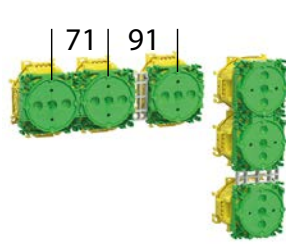

By using the 91 distance piece (Art. No. 1259-04), the combination distances for communication connections can be extended to 91 mm in 20 mm increments.



The B¹ one-gang box, B¹ one-gang junction box, B¹ large conduit one-gang junction box and the B¹ electronics box...



...can be connected stably and securely to both the front part and the box body.

The new conduit insertion technology

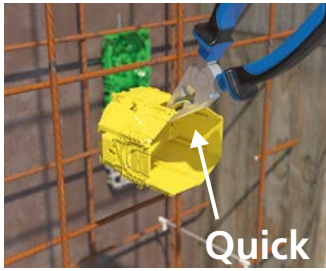

The required conduit connection opening can be easily and exactly broken out with a quick tilting movement using a standard pair of combination pliers,...

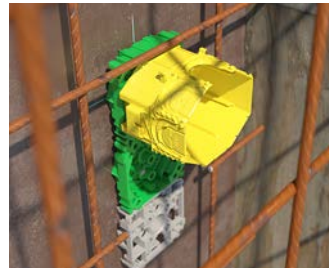

...for this purpose, the combination pliers are applied to the marked break-off edge for the required conduit size and broken out via a tilting movement.



Once all the required conduit entry openings have been created, the rear cover can be closed.





The conduit can now be inserted easily.

B¹ one-gang box

- with 4 screw domes and 2 expanding claw fields
- 2-piece with moulded rear part
- Two slots for B¹ Prefix[®] system wings
- Rear part of box with slot for support element
- Suitable for all types of formwork
- Standardised combination distance 71 mm



3D animation



Length x Width x Depth	94 x 75 x 59 mm
Installation opening Ø	60 mm
Break-out openings for DIN EN Ø 20/25 mm conduits	6
Markings for cables up to Ø 16 mm	6
Number of parts	2
 / 	Yes / Yes
Art.-No.	1255-01
Inner packaging/shipping	20 / 200

B¹ one-gang junction box

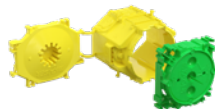
- with 4 screw domes and 2 expanding claw fields
- 2-piece with moulded rear part
- Two slots for B¹ Prefix[®] system wings
- Rear part of box with slot for support element
- Suitable for all types of formwork
- Standardised combination distance 71 mm



3D animation

Length x Width x Depth	94 x 75 x 91 mm
Installation opening Ø	60 mm
Break-out openings for DIN EN Ø 20/25 mm conduits	7
Markings for cables up to Ø 16 mm	7
Number of parts	2
 / 	Yes / Yes
Art.-No.	1265-01
Inner packaging/shipping	20 / 100

B¹ One-gang boxes, B¹ One-gang junction boxes



for on-site mixed concrete

B¹ large conduit one-gang junction box

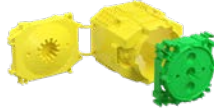
- with 4 screw domes and 2 expanding claw fields
- 2-piece with moulded rear part
- Two slots for B¹ Prefix[®] system wings
- Rear part of box with slot for support element
- Suitable for all types of formwork
- Standardised combination distance 71 mm



3D animation



Length x Width x Depth	94 x 75 x 106 mm
Installation opening Ø	60 mm
Break-out openings for DIN EN Ø 32/40 mm conduits	3
Markings for cables up to Ø 16 mm	3
Number of parts	2
 / 	Yes / Yes
Art.-No.	1260-01
Inner packaging/shipping	20 / 100

B¹ wall light connection box

- space for 3 terminal blocks and associated cables
- 2-piece with moulded rear part
- Two slots for B¹ Prefix[®] system wings
- Rear part of box with slot for support element
- Suitable for all types of formwork



3D animation

Length x Width x Depth	94 x 75 x 59 mm
Installation opening Ø	35 mm
Break-out openings for DIN EN Ø 20/25 mm conduits	6
Markings for cables up to Ø 16 mm	6
Number of parts	2
 / 	Yes / Yes
Art.-No.	1248-01
Inner packaging/shipping	20 / 200

B¹ universal wall exit

- Accessory fitting without drilling or dowelling
- space for 3 terminal blocks and associated cables
- Grey front part version for exposed concrete applications
- 2-piece with moulded rear part
- Two slots for B¹ Prefix® system wings
- Rear part of box with slot for support element
- Suitable for all types of formwork



3D animation

Length x Width x Depth	95 x 90 x 67 mm
Installation opening Ø	45 mm
Break-out openings for DIN EN Ø 20/25 mm conduits	6
Markings for cables up to Ø 16 mm	6
Number of parts	2
Art.-No.	1248-03
Inner packaging/shipping	20 / 180

Note

According to DIN VDE 0100, Part 559, feed lines for wall lights must terminate in connection boxes. Wall light connection boxes must have at least one option for attaching wall lights. According to DIN VDE 60670, wall and ceiling luminaire connection boxes must provide enough room for 3 individual terminals or be fitted with a 3-pole connector.

Installation with the universal screw-on surface



B¹ Universal wall exit



B¹ Universal wall exit with Prefix® installation technology.

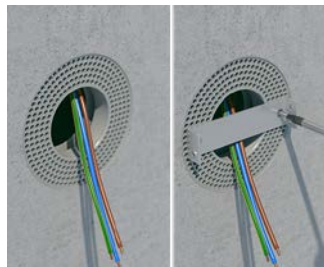

In addition, thanks to the universal screw-on surfaces, the complete installation can be done...



For wall lights, for example, only screws and a cordless screwdriver are needed.

One-gang box

- with 4 screw domes and 2 expanding claw fields
- suitable for all types of form-work
- combinations have fully-insulated cable transitions
- Standardised combination distance 71 mm



Depth	41 mm
Installation opening Ø	60 mm
Markings for cables and DIN EN conduits to Ø 16 mm	2
Number of parts	2
Art.-No.	1255-43
Inner packaging/shipping	10 / 100

One-gang boxes, One-gang junction boxes for on-site mixed concrete

Junction box

- cover screw distance 67 mm
- suitable for all types of form-work



Depth	66 mm	66 mm
Installation opening Ø	70 mm	70 mm
Markings for cables and DIN EN conduits up to Ø 25 mm	Yes	Yes
Rear part with holder for support element	Yes	Yes
Number of parts	2	2
with cover and cover screws	Yes	-
Art.-No.	1276-70	1276-71
Inner packaging/shipping	10 / 100	10 / 100

One-gang box PERILEX®

- device screws distance 67 mm
- with 2 countersunk device screws Ø 4 mm, length 16 mm
- for use with 16 A PERILEX® inserts
- suitable for all types of form-work



Depth	66 mm
Installation opening Ø	70 mm
Markings for cables and DIN EN conduits up to Ø 25 mm	Yes
Rear part with holder for support element	Yes
Number of parts	2
Art.-No.	1276-40
Inner packaging/shipping	10 / 100

One-gang box CEE

- device screws distance 67 mm
- With sealing ring for protection class IP 34 and 2 raised head 4 mm Ø device screws, length 20 mm
- for use with 16A CEE equipment inserts
- suitable for all types of form-work



Depth	66 mm
Installation opening Ø	70 mm
Markings for cables and DIN EN conduits up to Ø 25 mm	Yes
Rear part with holder for support element	Yes
Number of parts	3
Art.-No.	1275-40
Inner packaging/shipping	10 / 100

B¹ Electronics box and B¹ two-gang junction box

The B¹ electronics box and B¹ two-gang junction box are especially suitable for installations in on-site mixed concrete vertical formwork. The B¹ electronics box provides plenty of space for accessory installations, and additional space for devices such as switch actuators or other components for smart home applications. The relevant separator wall allows the standardised installation of bus and operating voltages in a single box. B¹ Two-gang junction boxes allow the installation of block and pre-wired accessories, and provide space for the assembly of cable for multi-media connections.

- Plenty of space for accessories and cables
- Separator wall for the standardised incorporation of two voltage types
- Flat front part for fast, easy nailing
- Innovative conduit entries for fast processing on the construction site
- Slot for B¹ Prefix® system wing set
- Spring travel ensures secure fit in standing formwork

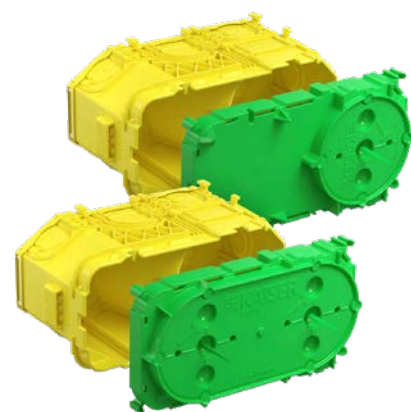

Examples of applications for the B¹ electronics box



By inserting the separator wall, two different voltage types can be fitted in a standardised way in the B¹ electronics box. In addition, they provide a generously-sized installation space...

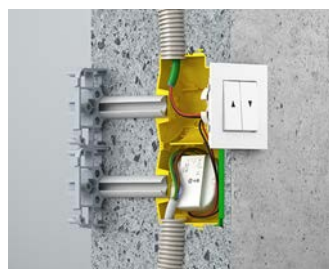

...for the decentral installation of, for example, small window actuators for controlling Venetian blinds and heating in the external wall.

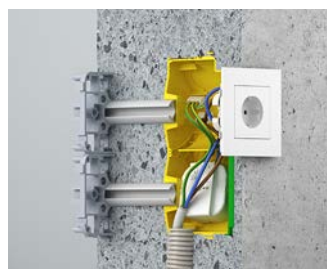

Thanks to the B¹ electronics box, it is easy to install radio-controlled actuators etc. without putting excessive strain on cables or accessories.



Network connection boxes can be used while maintaining the cable bending radii and with the best possible data transfer speeds.

Examples of applications for the B¹ two-gang junction box

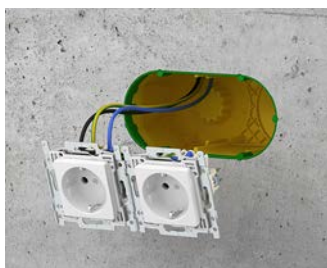

Thanks to its large installation opening without a central bridge, the B¹ two-gang junction box allows...



...the use of pre-wired accessories, pre-wired block inserts and many more.

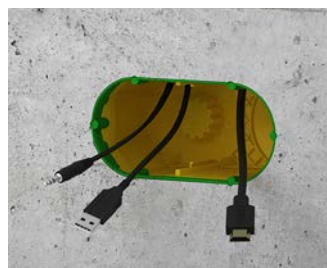

It also provides an easy-to-use basis for the installation of multi-media connection boxes. The very large installation compartment has plenty of space for configuring cables.



Reserve cables and connection plugs can easily be inserted into the box and are then concealed behind the installation accessories.



B¹ Electronics box and B¹ two-gang junction box for on-site mixed concrete

B¹ electronics box

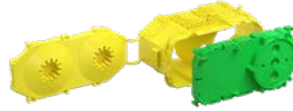
- with separator wall for separating electrical circuits
- with 4 screw domes
- Suitable for all types of formwork
- 2-piece with moulded rear part
- Two slots for B¹ Prefix[®] system wings
- Rear part of box with slot for support element
- Standardised combination distance 71 mm



3D animation



Length x Width x Depth	160 x 75 x 91 mm
Installation opening Ø	60 mm
Break-out openings for DIN EN Ø 20/25 mm conduits	7
Break-out openings for DIN EN Ø 32/40 mm conduits	2
Markings for cables up to Ø 16 mm	7
Number of parts	9
 / 	Yes / Yes
Art.-No.	1268-01
Inner packaging/shipping	5 / 50

B¹ double one-gang junction box

- 6 screw domes
- Suitable for all types of formwork
- 2-piece with moulded rear part
- Two slots for B¹ Prefix[®] system wings
- Rear part of box with slot for support element
- Standardised combination distance 71 mm



3D animation

Length x Width x Depth	160 x 75 x 91 mm
Installation opening Ø	60 x 131 mm
Break-out openings for DIN EN Ø 20/25 mm conduits	7
Break-out openings for DIN EN Ø 32/40 mm conduits	2
Markings for cables up to Ø 16 mm	7
Number of parts	9
 / 	Yes / Yes
Art.-No.	1269-01
Inner packaging/shipping	5 / 50

Distance piece 91

- for separate covers for antenna sockets in combinations with sockets without electric shock protection
- Centre distance 91 mm
- for multiple row combinations
- fits one-gang boxes, one-gang junction boxes, abutments

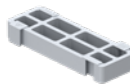

Length	60 mm
Art.-No.	1259-04
Inner packaging/shipping	10 / 100

B¹ Prefix® system wings

The B¹ Prefix® system wing allows fast, easy fixing to the reinforcement. This means optimal installation on the opposing formwork side and for free-standing reinforcement, and also for sliding or travelling formwork constructions. All wall applications in the new B¹ range have slots for the locking of two Prefix® system wings. This ensures fast, easy installation on the opposing formwork side.

- Fast and easy installation on opposing formwork without support element and abutment
- Holding in place using the Prefix® installation technology leaves both hands free for securing with tie wires
- A pronounced corrugated profile and additional fixing opportunities for secure fixing using tie wires
- Combinable when using wall and ceiling transitions
- For installation in exposed concrete, pressed against the front formwork
- Suitable for 20 - 60 mm concrete covers



Examples of use



Connect the B¹ Prefix® system wings to the slot of the B¹ one-gang box which you are installing.

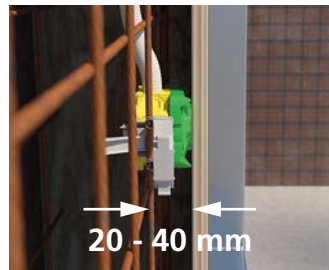

During installation, the front side of the B¹ one-gang box must protrude from the wall thickness by between 5 and 20 mm. This ensures optimal pressure on the opposing formwork.

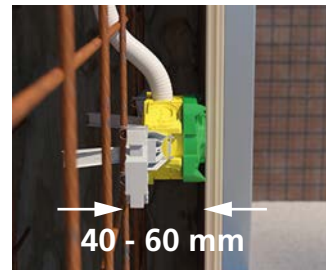

If the B¹ one-gang box is less than the required wall thickness: Turn the B¹ Prefix® system wing by 180°, connect it again to the B¹ one-gang box, pre-fix the box...



...to the reinforcement and, using both hands, secure to the reinforcement by means of tie wires.

B¹ Prefix® system wing bracket set

- Facilitates fixing to the reinforcement
- Pre-fixing by means of B¹ Prefix® installation technology
- Can be used for the following articles:
- B¹ device socket
- B¹ device connection socket
- B¹ large-conduit device connection socket
- B¹ electronics socket
- B¹ two-device connection socket
- B¹ wall light connection socket
- B¹ universal wall outlet
- B¹ Prefix® adapter - Ø 20, Ø 25 and Ø 32 mm



3D animation

Length x Width x Depth	103 x 49 x 36 mm
For concrete coverings of	20 - 60 mm
Number of wings	2
Art.-No.	1211-00
Inner packaging/shipping	1 / 175

Junction casings and accessories

for on-site mixed concrete



Junction casings

Junction casings in all sizes and for almost any kind of installations. This product range features practical housing sizes as well as a robust housing design which is perfect for building sites.

- As central junction casings for star-shaped cable laying.
- Easy to rewire when changing the way rooms are used.
- Separator walls to separate electrical circuits.
- End cover with screw attachment for VDE-compliant installation.



Processing instructions



Open the universal conduit entry with one hammer blow.



The junction casing and the support on the working form-work create a stable unit.

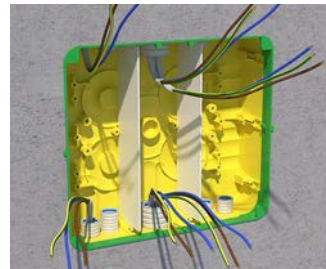

KAISER junction casings offer plenty of space for electrical installation according to DIN 18015-3.

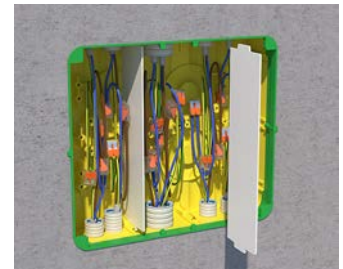

Separator walls ensure that electrical circuits are safely separated.

Junction casing

- for terminals up to 16 mm²
- suitable for all types of form-work
- rear parts of casing with holder for support element
- for loose terminals up to 4 mm²



Length x Width x Depth	128 x 128 x 80 mm	180 x 180 x 84 mm	250 x 220 x 82 mm
Number of parts	2	2	2
Entry fields	8	8	10
possible DIN EN conduit sizes per entry field: 4 x 16 mm Ø, 3 x 20 mm Ø, 1 x 25 mm Ø, 1 x 32 mm Ø, 1 x 40 mm Ø	Yes	-	-
use separator wall for maximum of 2 electrical circuits	-	Yes	-
possible DIN EN conduit sizes per entry field: 4 x 16 mm Ø, 4 x 20 mm Ø, 1 x 25 mm Ø, 1 x 32 mm Ø, 1 x 40 mm Ø	-	Yes	-
Maximum of 3 electrical circuits with separator walls	-	-	Yes
possible DIN EN conduit sizes per entry field: 6 x 16 mm Ø, 3 x 20 mm Ø, 2 x 25 mm Ø, 1 x 32 mm Ø, 1 x 40 mm Ø	-	-	Yes
	Yes	Yes	Yes
Art.-No.	1295-02	1296-02	1297-02
Inner packaging/shipping	1 / 10	1 / 10	1 / 5

Equipotential bonding casing 10² and 16²

- including equipotential bonding busbar, corrosion protected
- for bathrooms or similar
- including cover



Length x Width x Depth	250 x 220 x 82 mm	128 x 128 x 80 mm
Cables up to 16 ² , single and stranded wire	7	-
Circular conductors Ø 8–10 mm	1	-
Flat strip up to 30 mm wide	1	-
Entry fields	8	8
possible DIN EN conduit sizes per entry field: 6 x 16 mm Ø, 3 x 20 mm Ø, 2 x 25 mm Ø, 1 x 32 mm Ø, 1 x 40 mm Ø	Yes	-
Cables 1.5–10 ²	-	6
Circular conductor 6–16 ²	-	1
possible DIN EN conduit sizes per entry field: 4 x 16 mm Ø, 3 x 20 mm Ø, 1 x 25 mm Ø, 1 x 32 mm Ø, 1 x 40 mm Ø	-	Yes
	Yes	-
Art.-No.	1297-75	1295-73
Inner packaging/shipping	- / 1	1 / 10



Note

Other earthing products can be found at our website.

Flush-mounted junction box

- For wood and steel formwork on in-situ concrete and for flush-mounted (masonry) installations
- With internally fitting cover as adhesive attachment surface
- Where fixing to vertical formwork and using adhesive to attach, the box must be mounted on a telescopic support (item no. 9957)
- For loose terminals up to 4 mm²

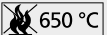

Length x Width x Depth	115 x 115 x 76 mm	115 x 115 x 101 mm	115 x 115 x 150 mm
Break-out openings Ø 20 mm	16	16	16
Combination conduit entries M20/25	4	8	8
Number of nails	4	4	4
 650 °C / 	Yes / Yes	Yes / Yes	Yes / Yes
CE	Yes	Yes	Yes
Art.-No.	9909.01	9908.01	9908.21
Inner packaging/shipping	- / 50	- / 30	- / 5

Junction casings and accessories

for on-site mixed concrete

Flush-mounted junction boxes

- For wood and steel formwork on in-situ concrete and for flush-mounted (masonry) installations
- With internally fitting cover as adhesive attachment surface



Length x Width x Depth	115 x 115 x 105 mm	115 x 115 x 150 mm
Break-out openings Ø 20 mm	12	12
Combination conduit entries M20/25	4	4
Combination conduit entries M25/32	2	2
Number of nails	4	4
650 °C /	Yes / Yes	Yes / Yes
CE	Yes	Yes
Art.-No.	9907	9907.21
Inner packaging/shipping	- / 20	- / 5

Extension pieces for flush-mounted junction boxes

- For increasing the front-to-back depth of the box or for sub-ceiling insulation
- Multiple extensions possible
- With two fixing screws



Length x Width x Depth	115 x 115 x 13 mm	115 x 115 x 12 mm	115 x 115 x 45 mm
Number of screws	-	2	2
850 °C /	Yes / Yes	Yes / Yes	Yes / Yes
CE	Yes	Yes	Yes
Art.-No.	9908.68	9907.68	9907.68.45
Inner packaging/shipping	- / 10	- / 10	- / 5

Plug-in cover

- smooth surface with rounded edge



Length x Width x Height	130 x 130 x 7 mm	130 x 130 x 3.5 mm	130 x 130 x 3.5 mm	130 x 130 x 3.5 mm
Colour	RAL 9010	RAL 9010	RAL 9010	RAL 9010
850 °C /	Yes / Yes	Yes / Yes	Yes / Yes	Yes / Yes
CE	Yes	Yes	Yes	Yes
Art.-No.	9909.22	9909.20	9909.10	9909.12
Inner packaging/shipping	- / 10	- / 10	- / 10	- / 10

Screw-in cover

- smooth surface with rounded edge



Length x Width x Height	130 x 130 x 3.5 mm
Number of plastic screws	4
Art.-No.	9909.02 S
Inner packaging/shipping	- / 10

Waterproof cover

- Anodised aluminium
- with full neoprene seal
- Cover fixing with enclosed screws, non-rusting



Length x Width x Height	130 x 130 x 1.5 mm
Screws	4x, Ø 4x35
Art.-No.	9909.03
Inner packaging/shipping	- / 100

Adhesive foil

- for anti-shock fixing of boxes and casings in horizontal formwork
- for vertical formwork, additional bracing must be provided using a support element and abutments
- Degreasing formwork
- Double-sided adhesion



Art.-No.	1219-00
Inner packaging/shipping	200 / 1000

FLUSH-MOUNTING

CAVITY WALL

CONCRETE

HOUSINGS

FIRE PROTECTION

PLUGGABLE

CONNECTIVITY

CABLE GLANDS

TOOLS

SERVICE

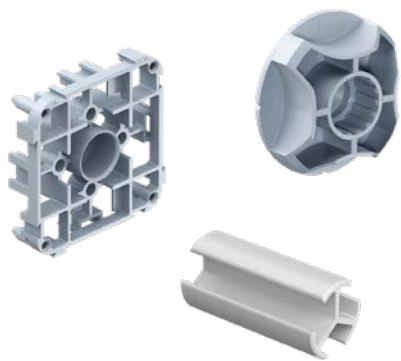

Abutment and support elements

The on-site mixed concrete programme offers special abutments and support elements for the installation of opposing one-gang boxes or the installation of one-gang boxes and junction casings on the opposite side of the formwork. For this purpose, there are holders in the back of the item that provide the support elements with a anti-rotation hold. The curved base of the box facing outwards forms an integrated spring travel, which is used to compensate for component-related tolerances when setting the opposing formwork by compressing it.

- Two abutments for fixing to the working formwork using expanding dowels, nails, screws or adhesive foil
- No blocking of conduit entries thanks to the anti-rotation support element attachments in the back of the one-gang boxes and junction casings
- The integrated spring travel ensures a secure hold between the working and opposing formwork and compensates for construction tolerances
- Thanks to their star-shaped contour, the support elements ensure that the concrete flows around the entire surface

Calculation for the supporting elements

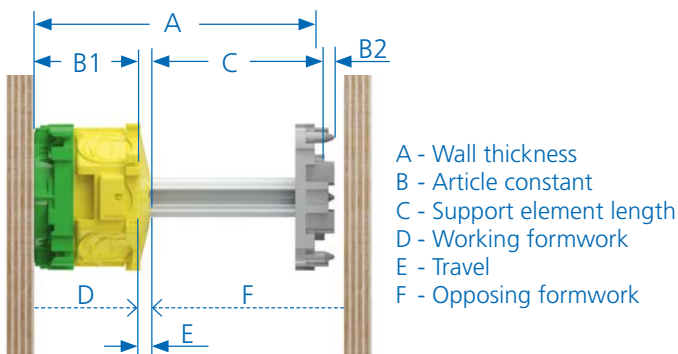

Length of the support elements. (e.g. vertical formwork)

General formula:	$C = A - (B1 + B2)$
Wall thicknesses:	A = 200 mm
Article constants for one-gang box 1255-01:	B1 = 40 mm
Article constants for abutments 1210-02:	B2 = 5 mm
Length support element	$C = 200 \text{ mm} - (40 \text{ mm} + 5 \text{ mm})$
	C = 155 mm

Important: Take formwork inaccuracies as opposed to planned wall thickness into account! Always specify length of support elements accurately in mm when ordering!

Product description	Art. no.	Standard article thickness "B"	
		Vertical	Horizontal
B ¹ one-gang box	1255-01	40	46
B ¹ one-gang junction box	1265-01	72	78
B ¹ large conduit one-gang junction box	1260-01	87	93
B ¹ electronics box	1268-01	72	78
B ¹ double one-gang junction box	1269-01	72	78
B ¹ wall light connection box	1248-01	40	46
B ¹ universal wall exit	1248-03	48	54
Junction casings	1295-02/73	58	64
Junction casings	1296-02	64	70
Junction casings	1297-02/75	60	66
PERILEX® one-gang box	1276-40	45	51
CEE one-gang box	1275-40	45	51
Junction box	1276-70/-71	45	51
Abutment	1210-02	5	7
Abutment with adhesive	1205-02	5	7
One-gang box	1223-41	44	50
Two-gang box	1224-41	47	53
Box for Italian / American standard	1200-00	39	45
Universal installation housings	1223-22	57	63
Universal installation housings	1224-22	60	66
Universal installation housings	1295-22	71	77
Universal installation housings	1296-22	77	83
Universal installation housings	1297-22	73	79
Wall and ceiling transition 30°	1202-04	62	62
Wall and ceiling transition 30°	1202-34	62	62
Wall and ceiling transition 30°	1202-29	62	62

Installation to the opposing formwork side by means of a support element



To determine the support element length, simply position the desired one-gang boxes opposite each other and stop at the planned wall thickness.



Afterwards, the required support element length can simply be measured at the markings provided on the B¹ one-gang box and then sawn off.



The prepared B¹ one-gang box protrudes approx. 5 to 10 mm beyond the planned wall thickness, so that the unit is braced between the working formwork and opposing formwork when the formwork is closed.



The integrated spring travel in the rear part of the B¹ one-gang box compensates for construction tolerances, such as the breathing of the formwork during the concreting process, and holds the B¹ one-gang box securely in position.

Abutment for adhesive foil

- for support element Ø 20 mm
- Fixing to formwork using 1219-00 adhesive foil



Art.-No.	1205-02
Inner packaging/shipping	- / 250

Abutment

- for support element Ø 20 mm
- can be combined with itself, with one-gang boxes, one-gang junction boxes, junction casing, universal installation housings and distance pieces 91
- Fixing to the formwork using expanding dowels, nails or screws



Art.-No.	1210-02
Inner packaging/shipping	- / 250

Support element Ø 20 mm

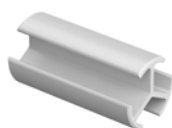

Length	Art.-No.	Inner packaging/shipping
≤ 40 mm	1212-04	- / 1
41 - 60 mm	1212-06	- / 1
61 - 80 mm	1212-08	- / 1
81 - 100 mm	1212-10	- / 1
101 - 120 mm	1212-12	- / 1
121 - 140 mm	1212-14	- / 1
141 - 160 mm	1212-16	- / 1
161 - 180 mm	1212-18	- / 1
181 - 200 mm	1212-20	- / 1
1.000 mm	1212-98	- / 80
3.000 mm	1212-99	- / 1

Note

On request, we can supply support conduits with Ø 20 mm for wiring through the support element.

Subject to modifications

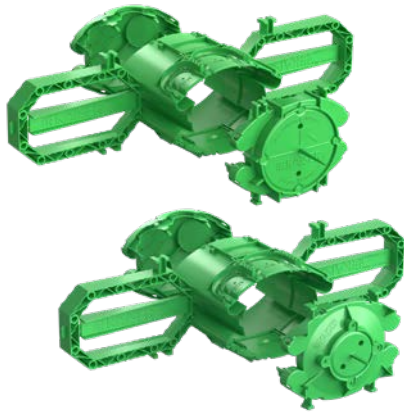

Prefix® concrete construction box for fixing to the reinforcement

The new Prefix® concrete construction boxes, in addition to the proven product features such as lateral installation clamps for fastening to the reinforcement, mounting clips for pre-fixing the items and marked wave profile for an exact and secure fit, now also have innovative conduit entries, insertion options in the rear part of the box as well as separators that can be broken out at a later date for connecting devices in combinations.

- Quick and easy installation on the opposing formwork, without support element and abutment
- Spacers to the side formwork ensure full circulation of the concrete and allow exposed concrete installations in passage and edge areas
- Suitable for 20 - 60 mm concrete covers
- Innovative conduit entries with diameters of 25/32 mm and 20/25 mm, for quick fitting on the construction site
- Insertion options up to 25 mm diameter on the rear base of the box
- Easy manual assembly
- Sturdy signal bristle and bold colouring for easy retrieval in the concrete surface
- Large inlay and installation clearance
- Easy installation of pre-wired installation accessories in multiple combinations using a bridge that can be broken off afterwards



Setting the concrete covers 20 - 40 mm / 40 - 60 mm



The assembly of the box for a concrete cover of 20 to 40 mm is carried out by installing the conduit entries at the bottom of the box.



This means that the conduit entries are located behind the first reinforcement layer and that time-consuming and destabilising reinforcement cuts are no longer necessary.



A concrete cover of 40 to 60 mm is also possible by simply turning the box upside down. For this purpose, the conduit entries must be arranged on the front part.



This means that the conduit entries are located in front of the first reinforcement layer and also remain usable without restrictions. The conduits are to be routed behind the reinforcement at the earliest opportunity.

Prefix® concrete construction box Ø 60 mm

- One-gang junction box for fixing to the reinforcement
- Can be used for concrete coverings from 20 - 60 mm
- Pre-fixing by means of Prefix® installation technology
- 1-piece with moulded front and rear part
- Standardised combination distance 71 mm
- with 4 screw domes and 2 expanding claw fields
- Art. No. 1211-01 replaces Art. No. 1211-61



INNOVATION



Product-Data



3D animation

Length x Width x Depth	290 x 78 x 91 mm
Installation opening Ø	60 mm
Break-out openings for DIN EN Ø 25/32 mm conduits	2
Break-out openings for DIN EN Ø 20/25 mm conduits	4
Markings in the bottom of the box for conduits up to Ø 25 mm	2
Markings for wires and cables up to Ø 16 mm	8
	Yes
Art.-No.	1211-01
Inner packaging/shipping	25 / 50

Prefix® concrete construction box Ø 35 mm

- Wall-light connection box for fixing to the reinforcement
- Can be used for concrete coverings from 20 - 60 mm
- Pre-fixing by means of Prefix® installation technology
- 1-piece with moulded front and rear part
- Art. No. 1211-02 replaces Art. No. 1211-36



INNOVATION



Product-Data



3D animation

Length x Width x Depth	290 x 78 x 91 mm
Installation opening Ø	35 mm
Break-out openings for DIN EN Ø 25/32 mm conduits	2
Break-out openings for DIN EN Ø 20/25 mm conduits	4
Markings in the bottom of the box for conduits up to Ø 25 mm	2
Markings for wires and cables up to Ø 16 mm	8
	Yes
Art.-No.	1211-02
Inner packaging/shipping	25 / 50

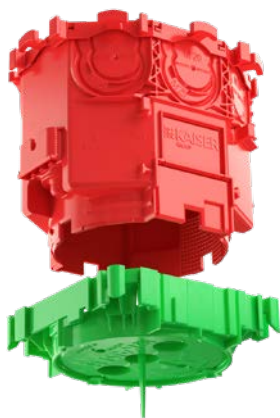

B¹ ceiling junction box

The new B¹ ceiling boxes simplify installation on the ceiling formwork. The innovative conduit entries enable conduits to be easily inserted into several ceiling boxes arranged in a row without having to cut them during the laying work. Due to the conduit entries located higher up, additional cut-outs of the reinforcement bars are unnecessary, ensuring fast insertion of the empty conduits on the ceiling.

- Suitable for all types of formwork
- Flat front part enables smooth insertion of the reinforcing bars on the ceiling formwork
- Innovative conduit entries for fast processing on the construction site
- Larger mounting and installation space
- Mounting of a light hook in accordance with DIN EN 60670
- The proven KAISER colour coding system ensures that the installation can be checked quickly



Installation on the ceiling formwork

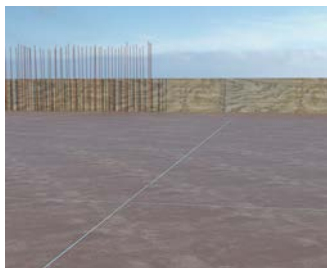

The exact position of the ceiling boxes is determined by means of a cord or tensioning a mason's lacing cord.

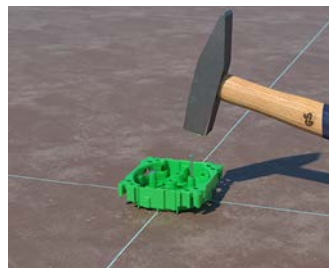

The shallow front part allows easy fixing to the ceiling formwork before the reinforcement bars are added.



The required conduit connection opening can be easily and exactly broken out with a quick tilting movement using a standard pair of combination pliers.

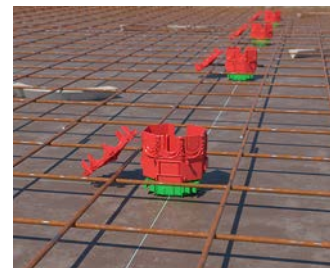

The conduit entries are above the lower reinforcement layer, so that no cutting of the reinforcement bars is necessary.



The advantage of the new conduit entry is that empty conduits can be inserted in several ceiling junction boxes without cutting the conduit beforehand.



After final visual inspection of the conduits, the cover can be closed simply by hand, at the same time providing secure conduit retention.



Universal screw-on surface / B¹ 45° universal ceiling exit (Art No. 1249-13).



Universal screw-on surface / universal ceiling exit (Art. No. 1265-13).

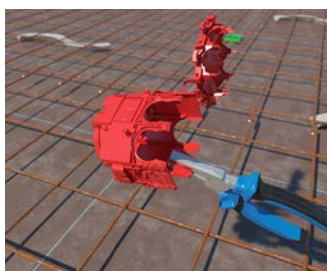

When inserting several conduits next to each other, open the conduit entries with combination pliers...

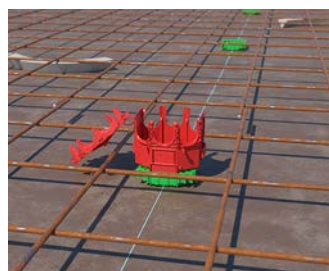

...latch the rear part onto the front part...

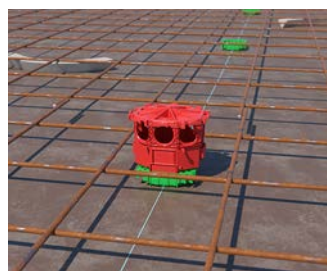

...and close the back cover before inserting the conduits.



The conduits can now simply be inserted into the prepared openings.

B¹ 45° domed box



- Rear part of box with holder for light hooks according to DIN EN 60670 (50 N)
- 2-piece with moulded rear part
- Suitable for all types of formwork
- Usable light hooks:
- 30 mm / Art. No. 1225-30
- 40 mm / Art. No. 1225-40
- 60 mm / Art. No. 1225-60



INNOVATION



3D animation

Length x Width x Depth	75 x 85 x 64 mm	75 x 85 x 64 mm
Installation opening Ø	60 mm	35 mm
Break-out openings for DIN EN Ø 20/25 mm conduits	4	4
Markings for cables up to Ø 16 mm	4	4
Number of parts	2	2
 / 	Yes / Yes	Yes / Yes
Art.-No.	1249-11	1249-12
Inner packaging/shipping	20 / 200	20 / 200

B¹ ceiling junction box



- Rear part of box with holder for light hooks according to DIN EN 60670 (50 N)
- 2-piece with moulded rear part
- Suitable for all types of formwork
- Usable light hooks:
- 100 mm / Art. No. 1225-10
- 120 mm / Art. No. 1225-12
- 140 mm / Art. No. 1225-14



INNOVATION



3D animation

Length x Width x Depth	94 x 75 x 95 mm	94 x 75 x 95 mm
Installation opening Ø	60 mm	35 mm
Break-out openings for DIN EN Ø 20/25 mm conduits	7	7
Markings for cables up to Ø 16 mm	7	7
Number of parts	2	2
 / 	Yes / Yes	Yes / Yes
Art.-No.	1265-11	1265-12
Inner packaging/shipping	20 / 100	20 / 100

Ceiling boxes, ceiling junction boxes

for on-site mixed concrete

B¹ large conduit ceiling junction box



- Rear part of box with holder for light hooks according to DIN EN 60670 (50 N)
- 2-piece with moulded rear part
- Suitable for all types of formwork
- Usable light hooks:
- 100 mm / Art. No. 1225-10
- 120 mm / Art. No. 1225-12
- 140 mm / Art. No. 1225-14



 INNOVATION



3D animation

Length x Width x Depth	94 x 75 x 110 mm
Installation opening Ø	60 mm
Break-out openings for DIN EN Ø 32/40 mm conduits	3
Markings for cables up to Ø 16 mm	3
Number of parts	2
 / 	Yes / Yes
Art.-No.	1260-11
Inner packaging/shipping	20 / 100

B¹ 45° universal ceiling exit

- Accessory fitting without drilling or dowelling
- Rear part of box with holder for light hooks according to DIN EN 60670 (50 N)
- Grey front part version for exposed concrete applications
- 2-piece with moulded rear part
- Suitable for all types of formwork



 INNOVATION



3D animation

Length x Width x Depth	90 x 90 x 72 mm
Installation opening Ø	45 mm
Break-out openings for DIN EN Ø 20/25 mm conduits	4
Markings for cables up to Ø 16 mm	4
Number of parts	2
Art.-No.	1249-13
Inner packaging/shipping	20 / 200



3D animation

B¹ universal ceiling exit

- Accessory fitting without drilling or dowelling
- Rear part of box with holder for light hooks according to DIN EN 60670 (50 N)
- Grey front part version for exposed concrete applications
- 2-piece with moulded rear part
- Suitable for all types of formwork



Length x Width x Depth	100 x 90 x 103 mm
Installation opening Ø	45 mm
Break-out openings for DIN EN Ø 20/25 mm conduits	7
Markings for cables up to Ø 16 mm	7
Number of parts	2
Art.-No.	1265-13
Inner packaging/shipping	20 / 100

Installation with the universal screw-on surface

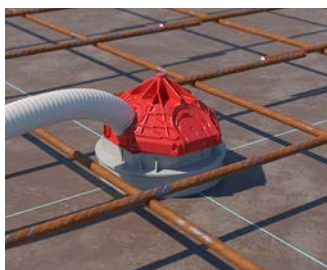

Universal screw-on surface / B¹ 45° universal ceiling exit (Art No. 1249-13).



Universal screw-on surface / universal ceiling exit (Art. No. 1265-13).



Universal screw-on surfaces enable quick and easy accessory installation without drilling and dowelling....



...in the ceiling area, for example, smoke detectors can be installed here easily and dust-free.

115 large slab ceiling box

- Installation height 115 mm, with M5 metal nut for light hook (min. hook length: 115 mm + plaster thickness)
- with screw-on cover for on-site fitting of conduits
- suitable for all types of form-work
- maximum light hook load according to DIN EN 60670 100 N (10 kg)



Depth	115 mm
Exit opening Ø	60 mm
Diameter	102 mm
Markings for cables and DIN EN conduits up to Ø 25 mm	8
Markings for cables and DIN EN conduits up to Ø 32 mm	4
Number of parts	3
	Yes
Art.-No.	1227-50
Inner packaging/shipping	- / 100

Ceiling boxes, ceiling junction boxes

for on-site mixed concrete

Slab ceiling box for retrofitting

- for retrofitting on the construction site
- with M5 metal nut for light hook (hook length min. 95 mm + plaster thickness)



Depth	100 mm
Number of parts	2
required drilling hole	65 mm
Art.-No.	1247-01
Inner packaging/shipping	- / 100

Light hook

- For retrofitting in ceiling boxes (EN 60670)
- maximum light hook load according to DIN EN 60670 100 N (10 kg)
- with M5 thread, fully insulated



Length of shank	Diameter hook	Overall length	Thread length	Art.-No.	Inner packaging/shipping
30 mm	26 mm	55 mm	10 mm	1226-30	- / 150
55 mm	26 mm	81 mm	10 mm	1226-55	- / 150
65 mm	26 mm	91 mm	10 mm	1226-65	- / 150
75 mm	26 mm	101 mm	10 mm	1226-75	- / 150
85 mm	26 mm	112 mm	10 mm	1226-85	- / 100
95 mm	26 mm	121 mm	10 mm	1226-95	- / 100
105 mm	26 mm	132 mm	10 mm	1226-97	- / 100
115 mm	26 mm	143 mm	10 mm	1226-98	- / 100
125 mm	26 mm	151 mm	10 mm	1226-99	- / 100

Universal ceiling and wall exit

Universal ceiling and wall exit with KSK technology for especially quick and safe installation. The universal Ø 85 mm screw-on surface permits the clean installation of luminaires, smoke detectors etc. without the need for drilling.

- Open the conduit entry with a hammer blow
- Combination entry for two conduit sizes
- Thanks to the integrated conduit stopper, it is not necessary to shorten the conduit inside.
- Clean installation of accessories on the universal screw-on surface without the need for drilling or using dowels



Processing instructions



The screws used to attach the device...



...can be easily screwed into the universal screw-on surface.



M20 combi-entry

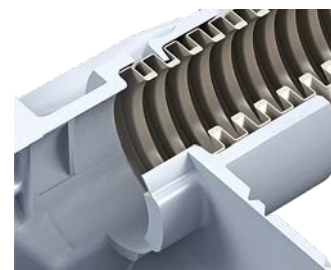

M25 combi-entry

Lamp box for flexible corrugated plastic conduits

- Conduit entry limitation to prevent the need to shorten the conduit inside
- Meets the product standard EN 60670-21 (suspension load) with our hook bolts 1225-xx
- Max. suspension load 50 N (5 kg)



Product-Data

Depth	105 mm
Exit opening Ø	48 mm
M20/M25 impact couplings	4
Number of parts	1
Number of nails	2
Outer diameter	85 mm
M25/M32 break-out opening	2
M20/M25 break-out opening	2
650 °C /	Yes / Yes
CE	Yes
Art.-No.	9959
Inner packaging/shipping	- / 25

Ceiling junction box

- Conduit entry limitation to prevent the need to shorten the conduit inside
- suitable for all types of form-work
- max. light hooks load in accordance with DIN EN 60670 (50 N)



Product-Data

Depth	99 mm	99 mm
Exit opening Ø	60 mm	35 mm
M20/M25 impact couplings	4	4
Number of parts	2	2
Screw domes for device attachment	4	-
M25/M32 break-out opening	2	2
M20/M25 break-out opening	2	2
650 °C /	Yes / Yes	Yes / Yes
CE	Yes	Yes
Art.-No.	1245-63	1245-62
Inner packaging/shipping	10 / 100	10 / 100

Light fitting support hooks, self-tapping

- For retrofitting in ceiling boxes (EN 60670)
- With self-forming thread, insulated
- Proof voltage: 2500 V tested
- Suspension load max. 5 kg



Length of shank	Art.-No.	Inner packaging/shipping
30 mm	1225-30	- / 100
40 mm	1225-40	- / 100
60 mm	1225-60	- / 100
80 mm	1225-80	- / 100
100 mm	1225-10	- / 50
120 mm	1225-12	- / 50
140 mm	1225-14	- / 50

Ceiling and wall exit

- for light hook attachment
- 2 entries (support shape) parallel to formwork level for 20 mm or 25 mm DIN EN conduits
- with formwork closing cover for one conduit entry



Length x Width x Depth	90 x 45 x 50 mm
Ceiling exit (CE) Ø	30 mm
Combination conduit entries M20/25	2
650 °C /	Yes / Yes
CE	Yes
Art.-No.	9951
Inner packaging/shipping	- / 50

Ceiling exit

- for light hook attachment and clamping material holder (box shape)
- with large attachment surface for smoke or motion detectors under the ceiling (no need for dowels)
- 4 entries (support shape) parallel to formwork level, 2 entries (support shape) 30° to formwork level, for 20 mm Ø DIN EN conduit

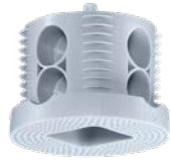

Depth	69 mm
Break-out openings Ø 20 mm	8
Outer diameter	85 mm
/	Yes / Yes
CE	Yes
Art.-No.	9955
Inner packaging/shipping	- / 50

Signal cover

- for wall and ceiling lights connection boxes
- for Art. Nos. 1248-40, 1245-62, 1248-50, 1248-44, 1264-50, 1211-36



For installation opening	35 mm
Art.-No.	1181-35
Inner packaging/shipping	- / 50

FLUSH-MOUNTING

CAVITY WALL

CONCRETE

HOUSINGS

FIRE PROTECTION

PLUGGABLE

CONNECTIVITY

CABLE GLANDS

TOOLS

SERVICE



End and transition grommets, wall and ceiling elbows 30°

End and transition grommets, and wall and ceiling 30°-elbows, for ensuring a continuously functioning conduit system at transition points. The particularly compact design of the end and transition grommets enables conduit outlets to be easily arranged - even between closely spaced reinforcement bars without needing to adjust the bars. The optimum elbow radius of the wall and ceiling elbow fittings, and their precisely fitting conduit entries, avoid the occurrence of protruding edges at interfaces, thus ensuring that cables can be freely inserted from both ends.

- Compact design for easy installation between closely spaced reinforcement bars
- Optimal elbow radius for easy cable insertion
- Installation against the (as yet unplaced) front formwork by means of a support strut with base plate to the rear formwork
- Two-part design with secure snap-in connection
- Easy removal of the sealing membrane
- Small visible area for neat wall/ceiling appearance



Product advantages

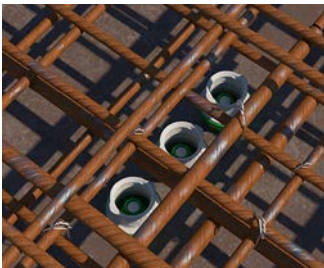

The new conduit outlet design makes it easy to feed conduits...



...even between closely spaced reinforcement bars.



The recess at the rear of the elbow piece for insertion of a support installation against the front formwork using a support strut with base plate.

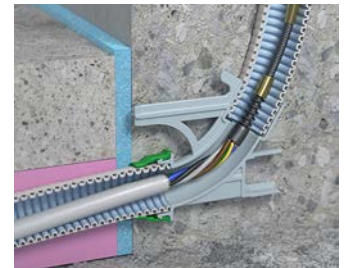

The optimal elbow radius of the unit facilitates flexible and easy cable insertion.

End and transition grommets

- For connecting conduits or as a ceiling outlet
- with sealing membrane at the formwork interface
- suitable for all types of form-work



3D animation



Product-Data



	32 mm	36 mm	41 mm
Height	32 mm	36 mm	41 mm
Diameter	30 mm	35 mm	41 mm
DIN EN conduit Ø	20 mm	25 mm	32 mm
Number of parts	2	2	2
Visible area Ø	23 mm	28 mm	35 mm
Art.-No.	1204-24	1204-34	1204-29
Inner packaging/shipping	50 / 500	25 / 100	25 / 100

End and transition grommet

- For connecting conduits or as a ceiling outlet
- with sealing membrane at the formwork interface
- suitable for all types of form-work



Length x Width x Height	95 x 65 x 70 mm
DIN EN conduit Ø	40 mm
Number of parts	1
Visible area Ø	95 x 65 mm
Art.-No.	1203-28
Inner packaging/shipping	10 / 40

Wall and ceiling elbow 30°

- For connecting conduits or as a ceiling outlet
- with sealing membrane at the formwork interface
- suitable for all types of form-work



3D animation



Product-Data



Length x Width x Height	70 x 30 x 77 mm	72 x 35 x 78 mm	80 x 41 x 83 mm
DIN EN conduit Ø	20 mm	25 mm	32 mm
Number of parts	2	2	2
Visible area Ø	23 mm	28 mm	35 mm
Art.-No.	1202-04	1202-34	1202-29
Inner packaging/shipping	25 / 250	25 / 100	25 / 100

Application examples

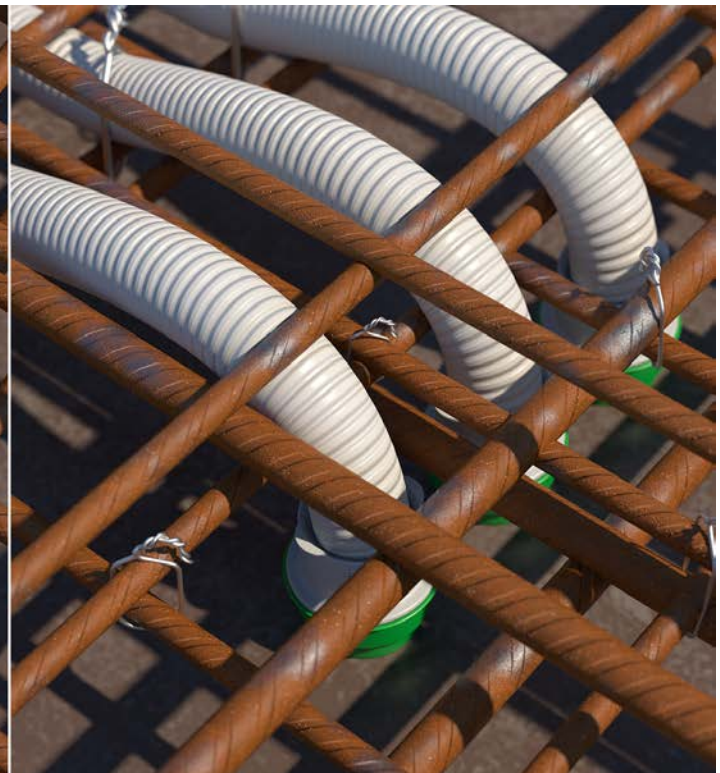
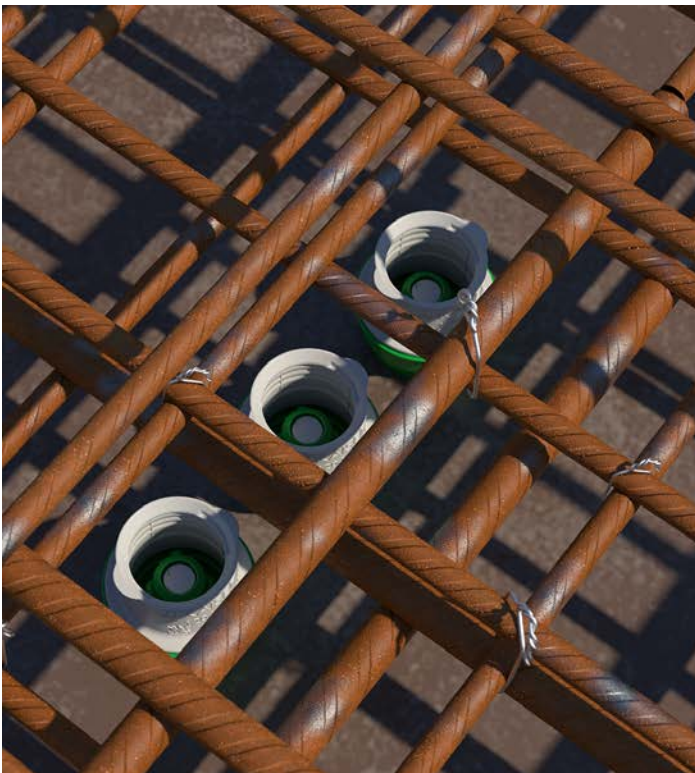

B¹ Prefix[®] wall outlet adapter

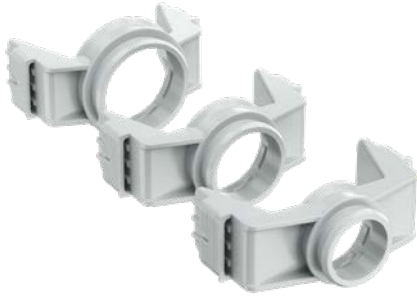

Using the B¹ Prefix[®] wall outlet adapter, end and transition grommets, and wall and ceiling 30°-elbows, can be easily and quickly fixed to the reinforcement for pressing against the (not yet placed) front formwork. They have two strong attachment slots, on opposite sides, for clicking the new Prefix[®] system wing brackets into place.

- Fast and easy installation on opposing formwork without support element and abutment
- For installation in exposed concrete, pressed against the front formwork



Examples of use



The B¹ Prefix[®] wall outlet adapter of the required size (Ø 20 mm, Ø 25 mm or Ø 32 mm) is simply snapped into place between the front and rear parts.



The B¹ Prefix[®] system wing brackets are now attached to the Prefix[®] wall outlet adapter in such a way that the planned concrete cover to the reinforcement will be achieved.



Pre-fix the wall outlet easily and quickly to the reinforcement using the Prefix[®] installation technology..



...and quickly tie it securely to the reinforcement, using both hands.

B¹ Prefix[®] wall outlet adapter - Ø 20 mm

- Facilitates fixing to the reinforcement
- Two slots for B¹ Prefix[®] system wings
- Can be used for the following articles:
- End and transition grommet / Article No. 1204-24
- Wall and ceiling elbow 30° / Article No. 1202-04



3D animation

For concrete coverings of	20 - 60 mm
Art.-No.	1211-20
Inner packaging/shipping	25 / 100

B¹ Prefix® wall outlet adapter - Ø 25 mm

INNOVATION



3D animation

- Facilitates fixing to the reinforcement
- Two slots for B¹ Prefix® system wings
- Can be used for the following articles:
- End and transition grommet / Article No. 1204-34
- Wall and ceiling elbow 30°/ Art. No. 1202-34



For concrete coverings of	20 - 60 mm
Art.-No.	1211-25
Inner packaging/shipping	25 / 100

B¹ Prefix® wall outlet adapter - Ø 32 mm

INNOVATION



3D animation

- Facilitates fixing to the reinforcement
- Two slots for B¹ Prefix® system wings
- Can be used for the following articles:
- End and transition grommet / Article No. 1204-29
- Wall and ceiling elbow 30°/ Art. No. 1202-29



For concrete coverings of	20 - 60 mm
Art.-No.	1211-32
Inner packaging/shipping	25 / 100

B¹ Prefix® system wing bracket set

INNOVATION



3D animation

- Facilitates fixing to the reinforcement
- Pre-fixing by means of B¹ Prefix® installation technology
- Can be used for the following articles:
- B¹ device socket
- B¹ device connection socket
- B¹ large-conduit device connection socket
- B¹ electronics socket
- B¹ two-device connection socket
- B¹ wall light connection socket
- B¹ universal wall outlet
- B¹ Prefix® adapter - Ø 20, Ø 25 and Ø 32 mm



Length x Width x Depth	103 x 49 x 36 mm
For concrete coverings of	20 - 60 mm
Number of wings	2
Art.-No.	1211-00
Inner packaging/shipping	1 / 175

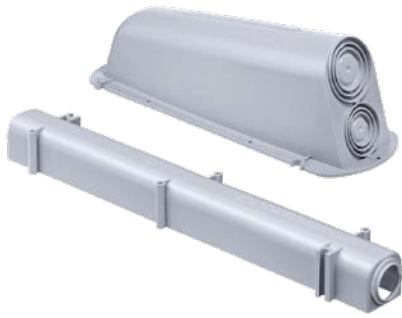

Ceiling strips

Ceiling strips for intermediate wall feeds, as ceiling exit or for connecting installation conduits. The elongated shape allows for compensation of big tolerances for lightweight intermediate wall feeds.

- For DIN EN conduits Ø 20 to Ø 25 mm
- Large tolerance compensation
- Exiting of two conduits at one exit site
- Can be combined for more than one adjacent exit
- Space for conduit ends for extending with conduit bushes



Ceiling strip (ceiling exit)

- Ceiling exit for intermediate wall feed, exit or conduit connector
- Accepts large tolerance compensation
- Open on formwork side
- Use wire-pull casing and junction casing 9914.01 for DIN EN conduits up to Ø 63 mm



Product-Data



Length x Width x Height x Depth	138 x 36 x 29 mm	138 x 36 x 29 mm	306 x 40 x 29 mm	270 x 90 x 82 mm
For conduits to DIN EN outer Ø	20 mm	25 mm	-	-
Combination conduit entries M20/25	-	-	2	-
Combination conduit entries M20/25/32	-	-	-	1
Combination conduit entries M25/32/40	-	-	-	1
650 °C	-	-	Yes	Yes
Art.-No.	1283-33	1283-34	4558	4552
Inner packaging/shipping	25 / 100	25 / 100	- / 50	- / 10

Speedy formwork protector

- Set of 5
- Connectable in a row
- Flexible slats grip inserted cable
- Tapered at the conduit entry points
- Flap cover - for more stability and safe stripping of formwork

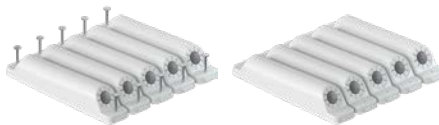

Length x Width x Depth	180 x 34 x 34 mm	180 x 34 x 34 mm
Number of nails	2	
650 °C	Yes	Yes
Art.-No.	4551.14	4551
Inner packaging/shipping	- / 50	- / 50

Ceiling strip 25° (ceiling exit)

- With 4 nails 3 x 50 mm
- Accepts large tolerance compensation
- Open on formwork side
- 25° conduit entry for laying conduit on the first reinforcement level
- for intermediate wall feed

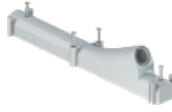

Length x Width x Depth	300 x 45 x 65 mm
Combination conduit entries M20/25	1
Number of nails	4
 650 °C	Yes
Art.-No.	4555
Inner packaging/shipping	- / 50

Conduit supports

- For secure fixing of conduits where they exit concrete ceiling slabs
- Prevents kinking of conduits

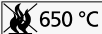

Length x Width x Height	130 x 132 x 210 mm	300 x 300 x 300 mm
DIN EN conduit Ø	16-40 mm	-
Steel diameter Ø	-	8 mm
 650 °C	Yes	-
Art.-No.	4560	11022
Inner packaging/shipping	- / 50	- / 25

Conduit bend support

- Prevents kinking of conduits

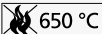

Length x Width x Height	170 x 107 x 225 mm
Number of nails	3
Radius	160
 650 °C	Yes
Art.-No.	4561
Inner packaging/shipping	- / 25

Conduit sealing cap

- for sealing conduit ends
- Halogen-free



DIN EN conduit Ø	20 mm	25 mm	32 mm
Art.-No.	1273-43	1273-44	1273-45
Inner packaging/shipping	100 / 1000	50 / 250	50 / 250

Central transition casing



NEW

The new central transition box for use in on-site mixed concrete ceilings or factory prefabricated ceiling elements is used for the central connection of conduits of different diameters. As a central feed-in point, it enables a clean transition to circuit distribution boxes and cable routing systems, allowing, for example, all the supply cables required for the electrical installation of a flat to be brought together at one transition point.

- For leaving out several cables, e.g. above an electrical distribution board located in the lightweight wall or surface-mounted
- For system magnetic, adhesive or nail fastening
- Conduit entries for Ø 20 mm, Ø 25 mm and Ø 32 mm on the long sides, up to Ø 63 mm on the short sides
- Positioning of the conduit entries above the first reinforcement layer or the top of the filigree ceiling
- Can be connected in a row as often as required



Application examples



Numerous entries for conduits from Ø 20 mm to Ø 63 mm.



The central transition casing for the exit of several conduits, e.g. is located in above in the lightweight wall...

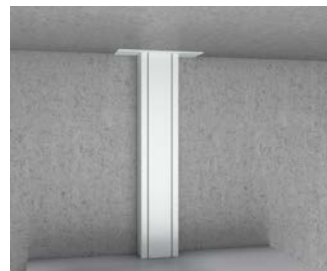

...or surface-mounted electrical distribution...

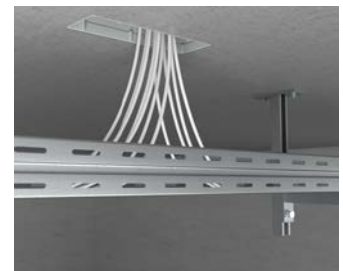

...as well as cable routing systems.

Processing instructions



Fixing by means of steel nails.



Fixing by means of KAISER system magnet (Art. No. 1299-69) or KAISER system magnet PLUS (Art. No. 1299-70).



Fixing by means of hot glue.



If required, several central transition casings can be lined up next to each other.

Central transition casing

- For system magnetic, adhesive or nail fastening
- Conduit entries for Ø 20 mm, Ø 25 mm and Ø 32 mm on the long sides, up to Ø 63 mm on the short sides
- The conduit entries are located above the first reinforcement layer or the top of the filigree ceiling

NEW



INNOVATION



3D animation



Product-Data

Length x Width x Depth	326 x 104 x 118 mm
Combination conduit entries M20/25	24
Combination conduit entries M25/32	6
Combination conduit entries M40/50/63	2
Extensive pull-out apertures	4
Number of nails	6
650 °C /	Yes / Yes
CE	Yes
Art.-No.	9914.10
Inner packaging/shipping	- / 10

Screw-in and moisture-proof cover ALU for central transition casing



NEW

INNOVATION

Length x Width x Height	330 x 120 x 5 mm	330 x 120 x 4 mm
Colour	RAL 9010	-
Screws	6	6
For type number	9914.10	9914.10
850 °C /	Yes / Yes	-
CE	Yes	-
Art.-No.	9914.10.02	9914.10.03
Inner packaging/shipping	- / 150	- / 50

Upper frame for central transition casing



NEW

INNOVATION

Length x Width x Depth	308 x 98 x 45 mm
For type number	9914.10
850 °C /	Yes / Yes
CE	Yes
Art.-No.	9914.10.68
Inner packaging/shipping	- / 5

Wire-pull casings

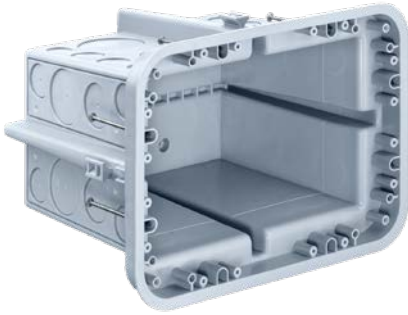

KAISER wire-pull casings ensure expert cable routing through conduit networks. According to DIN 18015-1, conduit lengths of more than 15 m and with more than two bends require wire-pull casings that allow cables to be added or retrofitted at any time. Wire-pull casings provide multiple conduit entry options and maximum free space to ensure a continuous cable network, including with subsequent changes to the electrical installation.

- Quick and secure installation using pre-inserted nails
- Clean stripping where exposed concrete is required
- High dimensional stability, no internal support required
- Multiple conduit entry options
- Stackable

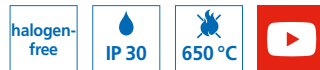

Examples of use



According to DIN 18015-1, pull-wire boxes are required for conduit sections of more than 15 m in length or when more than 2 bends are present.



KAISER wire-pull casings provide maximum room for the pulling and retrofiting of cables.



In case of sub-ceiling insulation, the wire-pull casing can be extended via intermediate frames



Also suitable for wall mounting - to be fastened to the reinforcement via Prefix® installation technology.

Flush-mounted junction boxes

- For wood and steel formwork on in-situ concrete and for flush-mounted (masonry) installations



Length x Width x Depth	175 x 120 x 64 mm	170 x 115 x 95 mm	250 x 105 x 94 mm
Break-out openings Ø 20 mm	2	2	-
Combination conduit entries M20/25	14	14	26
Combination conduit entries M20/25/32	4	6	2
Number of nails	4	4	4
Combination conduit entries M40/50/63	-	-	2
650 °C /	Yes / Yes	Yes / Yes	Yes / Yes
	Yes	Yes	Yes
Art.-No.	9912.01	9911.01	9914.01
Inner packaging/shipping	- / 5	- / 5	- / 10

Wire-pull casing

- For wood and steel formwork on in-situ concrete and for flush-mounted (masonry) installations
- Where fixing to vertical formwork and using adhesive to attach, the box must be mounted on a telescopic support (item no. 9957)
- Optional accessories: plaster cover, end cover, Prefix® installation set
- Simple mounting in wall using Prefix® installation technology



3D animation

Length x Width x Depth	250 x 180 x 120 mm	250 x 180 x 185 mm
Tube entries up to M25	12	20
Tube entries up to M32	8	8
Tube entries up to M40	4	8
Extensive pull-out apertures	8	8
Intake for Prefix	4	4
Number of nails	8	8
Tube entries up to M20	-	4
Tube entries up to M50	-	4
650 °C /	Yes / Yes	Yes / Yes
	Yes	Yes
Art.-No.	9916	9916.21
Inner packaging/shipping	- / 10	- / 5

Wire-pull casing

- For wood and steel formwork on in-situ concrete and for flush-mounted (masonry) installations
- Where fixing to vertical formwork and using adhesive to attach, the box must be mounted on a telescopic support (item no. 9957)
- Optional accessories: plaster cover, end cover, set of Prefix® wings
- Simple mounting in wall using Prefix® installation technology

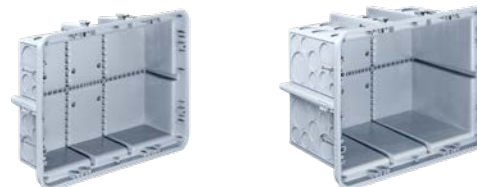

3D animation



Length x Width x Depth	400 x 300 x 120 mm	400 x 300 x 220 mm
Tube entries up to M25	16	24
Tube entries up to M32	8	20
Tube entries up to M40	2	20
Tube entries up to M50	8	12
Extensive pull-out apertures	10	10
Intake for Prefix	6	6
Number of nails	8	8
Tube entries up to M63	-	4
650 °C /	Yes / Yes	Yes / Yes
	Yes	Yes
Art.-No.	9917	9917.21
Inner packaging/shipping	- / 10	- / 5

Wire-pull casings

for on-site mixed concrete

Heightening frame



Length x Width x Depth	246 x 176 x 45 mm	397 x 297 x 45 mm
For type number	9916 / 9916.21	9917 / 9917.21
 850 °C / 	Yes / Yes	Yes / Yes
CE	Yes	Yes
Art.-No.	9916.68	9917.68
Inner packaging/shipping	- / 5	- / 5

Plastering covers

- For installation on rebar, without support element, before front formwork placed against it





Length x Width x Height	242 x 172 x 1 mm	390 x 290 x 1 mm
For type number	9916 / 9916.21	9917 / 9917.21
Art.-No.	9916.06	9917.06
Inner packaging/shipping	- / 30	- / 30

Screwed-on covers

- smooth surface with rounded edge
- UV-resistant



Length x Width x Height	270 x 200 x 5 mm	420 x 320 x 5 mm	262 x 112 x 5 mm	185 x 130 x 3.5 mm
Colour	RAL 9010	RAL 9010	RAL 9010	RAL 9010
Screws	4	6	-	4
For type number	9916 / 9916.21	9917 / 9917.21	9914.01	-
 850 °C / 	Yes / Yes	Yes / Yes	Yes	Yes / Yes
CE	Yes	Yes	Yes	Yes
Art.-No.	9916.02	9917.02	9914.02	9911.02
Inner packaging/shipping	- / 100	- / 50	- / 180	- / 5

Cover

- smooth surface with rounded edge
- suitable for Art. Nos. 9912.01 and 9911.01



Length x Width x Height	185 x 130 x 3.5 mm
Colour	RAL 9010
/	Yes / Yes
CE	Yes
Art.-No.	9911.12
Inner packaging/shipping	- / 5

Waterproof cover

- Anodised aluminium
- with full-surface elastomer sealing
- including stainless steel screws for cover fastening



Length x Width x Height	270 x 200 x 2 mm	420 x 320 x 2 mm	265 x 115 x 2 mm	186 x 130 x 1.5 mm
Screws	4	8	4	4x, Ø 4x35
For type number	9916 / 9916.21	9917 / 9917.21	9914.01	-
Art.-No.	9916.03	9917.03	9914.03	9911.03
Inner packaging/shipping	- / 50	- / 20	- / 50	- / 50

FLUSH-MOUNTING

CAVITY WALL

CONCRETE

HOUSINGS

FIRE PROTECTION

PLUGGABLE

CONNECTIVITY

CABLE GLANDS

TOOLS

SERVICE

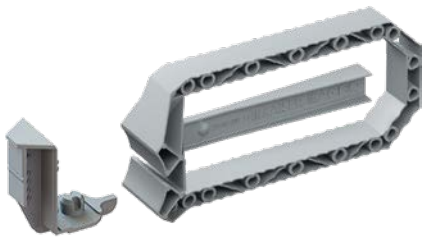



Assembly system Prefix®

Prefix® installation system for wire-pull casings for easy, fast installation on the opposing formwork without support. The wings are simply snapped into place. The spring-loaded clamps exert a strong force on the opposing formwork, thereby ensuring exact fitting of the wire-pull casing and a clean wall appearance.

- Fast and easy installation on opposing formwork without support element and abutment
- Holding in place using the Prefix® installation technology leaves both hands free for securing with tie wires
- For facing concrete installation to the opposing formwork



Required wings per product

	9902.22	9902.23	9902.24.40	9902.24	9902.26	9902.28	9902.29	9916*	9917*
	2	4	4	4	4	4	4	-	-
	-	-	-	-	-	-	-	4	4

* For Prefix® applications, please order the cover separately: 9916.06 / 9917.06

Prefix® wing set for inlet box 9902.xx

- Facilitates fixing to the reinforcement
- Fast and easy installation on opposing formwork without support element and abutment
- Holding in place using the Prefix® installation technology leaves both hands free for securing with tie wires



Length x Width x Height	150.1 x 59 x 16 mm	150.1 x 59 x 16 mm
Number of wings	4	12
 650 °C	Yes	Yes
Art.-No.	9940.25	9940.50
Inner packaging/shipping	- / 5	- / 10

Set of Prefix® wing brackets

- Facilitates fixing to the reinforcement
- For wire-pull casings (Art. No. 9907.10 and 9907.10.21)
- For wire-pull casings (Art. No. 9916 and 9917)

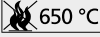

 INNOVATION

Length x Width x Height	137 x 59 x 16 mm
Number of wings	2
 650 °C	Yes
Art.-No.	9940.20
Inner packaging/shipping	- / 10

Universal installation housing

Universal installation housing for the installation of almost all device types and shapes in concrete walls and ceilings. The housing system consists of nine different installation housings and an extensive range of accessories.

- For displays, LED lights and much more
- For installing almost all shapes and sizes
- For installation in walls or ceilings
- For in-situ or prefabricated concrete
- For horizontal or vertical formwork and for masonry



Application example



The concreted-in housing with flush-mounted finish of the mineral fibreboard. The groove in the mineral fibreboard indicates the maximum installation area.



The support element in the installation housing prevents it being pressed inward during concreting.



When attaching the device to the installation housing, use only screws that go into but not right through the mineral fibreboard cover (e.g. SPAX countersunk head screw 3.5 x 15 mm)!



The front cover can be easily cut to create virtually any opening shape.

Note

The indicated wall thicknesses refer to walls without a fire protection function. The following applies to fire protection walls: Remaining wall thickness must be min. 60 mm. When using halogen lamps, pay attention to maximum power (see product details).

Universal installation housing with mineral fibreboard cover

- two-part, consisting of a rear housing and a front part with a mineral fibreboard insert
- all-round groove indicates the maximum opening size
- for loudspeakers, displays and LED lights



Length x Width x Depth	90 x 90 x 70 mm	150 x 90 x 70 mm	128 x 128 x 86 mm
Installation opening	40 x 40 mm	100 x 40 mm	75 x 50 mm
Device installation depth	60 mm	60 mm	65 mm
Ceiling thickness	≥ 140 mm	≥ 140 mm	≥ 140 mm
Wall thickness	≥ 110 mm	≥ 110 mm	≥ 120 mm
suitable for horizontal formwork	Yes	Yes	Yes
suitable for vertical formwork	Yes	Yes	Yes
Art.-No.	1223-22	1224-22	1295-22
Inner packaging/shipping	- / 10	- / 10	- / 10

Universal installation housings

for concrete ceilings and walls

Universal installation housing with mineral fibreboard cover

- two-part, consisting of a rear housing and a front part with a mineral fibreboard insert
- all-round groove indicates the maximum opening size
- incl. internal support element to strengthen the housing



Length x Width x Depth	180 x 180 x 90 mm	250 x 220 x 90 mm
Installation opening	120 x 100 mm	200 x 145 mm
Device installation depth	65 mm	65 mm
Ceiling thickness	≥ 140 mm	≥ 140 mm
Wall thickness	≥ 120 mm	≥ 120 mm
suitable for horizontal formwork	Yes	Yes
suitable for vertical formwork	Yes	Yes
Art.-No.	1296-22	1297-22
Inner packaging/shipping	- / 10	- / 5

Universal installation housing with mineral fibreboard cover

- suitable for installation in horizontal or vertical formwork and in masonry
- two-part, consisting of a housing and a mineral fibreboard cover
- Optional accessory: Set of Prefix® wing brackets



Length x Width x Depth	258 x 188 x 135 mm	258 x 188 x 200 mm	408 x 308 x 135 mm	408 x 308 x 235 mm
Installation opening	194 x 124 mm	194 x 124 mm	344 x 234 mm	344 x 234 mm
Device installation depth	105 mm	180 mm	115 mm	215 mm
Ceiling thickness	≥ 180 mm	≥ 240 mm	≥ 180 mm	≥ 280 mm
Wall thickness	≥ 180 mm	≥ 240 mm	≥ 180 mm	≥ 280 mm
Tube entries up to M25	12	20	16	24
Tube entries up to M32	8	8	8	20
Tube entries up to M40	4	8	2	20
Extensive pull-out apertures	8	8	10	10
Number of nails	8	8	8	8
max. output halogen luminaires	1x35 W QR-CBC, 1x50 W Alu	1x50 W QR-CBC, 1x75 W Alu	1x50 W QR-CBC, 1x75 W Alu	1x75 W QR-CBC, 2x50 W QR-CBC, 2x75 W Alu
Tube entries up to M20	-	4	-	-
Tube entries up to M50	-	4	8	12
Tube entries up to M63	-	-	-	4
 650 °C	Yes	Yes	Yes	Yes
Art.-No.	1298-37	1298-38	1297-34	1297-35
Inner packaging/shipping	- / 10	- / 10	- / 4	- / 4

Support technology for boxes and installation housings

Supporting by means of telescopic support: Junction boxes and installation housings can be installed on either side of a wall after the formwork has been placed on one side - either by fixing them directly to the rear (already placed) formwork or by supporting them off the rear formwork via a telescopic support. If the junction box is attached directly to the already-placed formwork or if heavy loading is to be expected due to a large concrete pouring height, additional securing by means of a telescopic support is recommended.

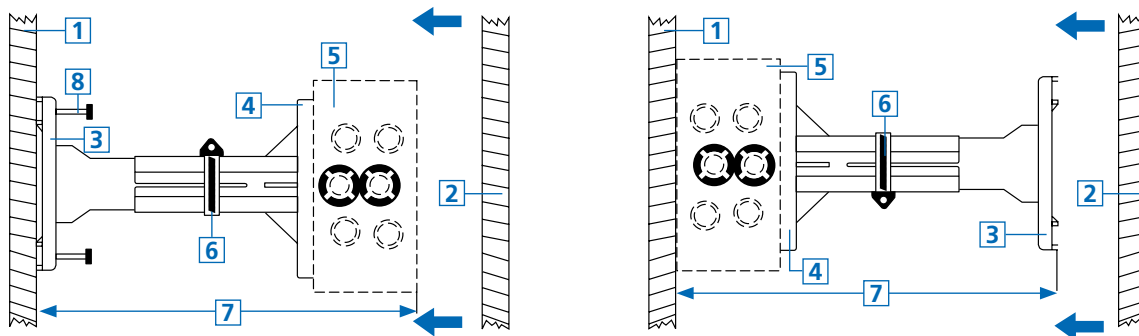

1 Working formwork | 2 Opposing formwork | 3 Base plate | 4 Supporting plate | 5 Junction casing | 6 Hose clamp | 7 Wall thickness +2 cm | 8 Nail

Note

When the formwork is closed, the junction box and the telescopic support are compressed between the formwork panels. The extra 2 cm of length allowed ensures sufficient pressure for a secure fit. Always tighten the hose clamp fully!

Telescopic support

- For supporting all boxes (99xx.xx without support element connection detail) on erected wooden formwork
- Fixing of the base plate by means of the four enclosed nails
- Fixing of the supported box by screwing onto the support plate
- Without extension piece, adjustable for wall thickness from 135 to 205 mm + depth of supported box. With enclosed extension piece, adjustable from 195 to 265 mm + depth of supported box.



Length x Width x Height	110 x 110 x 150-300 mm
Number of nails	4
 650 °C	Yes
Art.-No.	9957
Inner packaging/shipping	- / 10

International products



For international projects, we offer a large range of products that meet the relevant national standards and regulations.

- Dimensions and approvals based on national standards
- Suitable installation tools
- Many combination options



Installation



Fix the front part to the formwork (nail or screw fastening).



Make a conduit entry (punch pliers or universal opening cutter).



Inserting the conduits through exact openings.



Simple installation via snap-in connection.

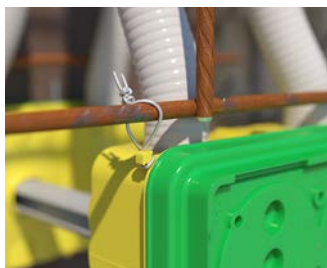

Tie lugs provide additional security if extreme loads are expected.



Open the concrete construction boxes, then install the accessory.



Simply click in the sliding nuts..

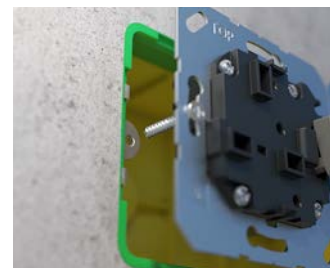

...enables the accessory inserts to be precisely aligned.

One-gang box for British accessories, one-gang



- Accessories can be aligned at any time by using to M 3.5 slide nuts
- Certified according to BS 4662 standard



One-gang box for British accessories, two-gang



- Accessories can be aligned at any time by using to M 3.5 slide nuts
- Certified according to BS 4662 standard



Length x Width x Depth	89 x 89 x 60 mm	149 x 89 x 60 mm
Screw spacing	60,3 mm	120,6 mm
Installation opening	68 x 68 mm	68 x 128 mm
Markings for cables and DIN EN conduits up to Ø 32 mm	4	6
Number of parts	2	2
Art.-No.	1223-41	1224-41
Inner packaging/shipping	- / 100	- / 100

Slide nuts for British accessories



- 2 pieces required per one-gang box
- for clipping into one-gang boxes 1223-41/1224-41
- protected against corrosion



Art.-No.	1224-99
Inner packaging/shipping	100 / 100

B¹ one-gang box Italian standard with 3 modules



- For 3 modules in monoblock construction
- Suitable for all types of formwork
- 2-piece with moulded rear part
- Two slots for B¹ Prefix® system wings
- Rear part of box with slot for support element
- Suitable for American accessories

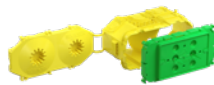

B¹ one-gang box Italian standard with 4 modules



- For 4 modules in monoblock construction
- suitable for all types of form-work
- 2-piece with moulded rear part
- Two slots for B¹ Prefix® system wings
- Rear part of box with slot for support element



Length x Width x Depth	160 x 75 x 91 mm	160 x 75 x 91 mm
Screw spacing	83 mm	108 mm
Break-out openings for DIN EN Ø 20/25 mm conduits	7	7
Break-out openings for DIN EN Ø 32/40 mm conduits	2	2
Markings for cables up to Ø 16 mm	7	7
Number of parts	2	2
Art.-No.	1269-03	1269-04
Inner packaging/shipping	5 / 50	5 / 50

One-gang box for Italian and American accessories



- For 3 modules in monoblock construction (single row)
- Installation opening 60 x 90 mm



One-gang box for Italian and American accessories



- Device screw spacing 2 x 83.5 mm, for installing Italian and American accessories
- for 2x3 modules in monoblock construction (double row)
- Installation opening 72 x 105 mm



Length x Width x Depth	100 x 68 x 55 mm	128 x 128 x 80 mm
Screw spacing	83 mm	-
Markings for cables and DIN EN conduits up to Ø 25 mm	8	-
Number of parts	2	2
Entry fields	8	8
possible DIN EN conduit sizes per entry field: 4 x 16 mm Ø, 3 x 20 mm Ø, 1 x 25 mm Ø, 1 x 32 mm Ø, 1 x 40 mm	-	Yes
	-	Yes
Art.-No.	1200-00	1295-02
Inner packaging/shipping	- / 100	1 / 10

One-gang box combinations for Swiss accessories



- incl. stabilising cover



Length x Width x Depth	78 x 78 x 58 mm
Break-out openings Ø 20 mm	9
Combination conduit entries M20/25	2
Number of nails	Yes
Halogen-free	Yes
/	Yes / Yes
/	Yes / Yes
Art.-No.	9918
Inner packaging/shipping	- / 50

Inlet box 2x1 to 4x1



- compatible with Feller SNAPFIX®
- Nail domes also serve as Prefix® connection points
- Increased stability
- Separately guided nailing points
- With separator wall and stabilisation lid
- For device screws Ø 3 mm
- Max. tightening torque 0.5 Nm



Length x Width x Depth	137 x 77 x 70 mm	197 x 77 x 70 mm	257 x 77 x 70 mm
Conduit entries M20	6	6	6
Conduit entries M25	6	6	6
Combination	2x1	3x1	4x1
Combination conduit entries M20/25	2	2	2
Drilling Center max. Ø 40 mm	--	2	4
/	Yes / Yes	Yes / Yes	Yes / Yes
/	Yes / Yes	Yes / Yes	Yes / Yes
Art.-No.	9902.22	9902.23	9902.24.40
Inner packaging/shipping	- / 50	- / 28	- / 20

Inlet box 2x2 to 4x2



- compatible with Feller SNAPFIX®
- Nail domes also serve as Prefix® connection points
- Increased stability
- Separately guided nailing points
- With separator wall and stabilisation lid
- For device screws Ø 3 mm
- Max. tightening torque 0.5 Nm



Length x Width x Depth	137 x 137 x 70 mm	197 x 137 x 70 mm	257 x 137 x 70 mm	197 x 197 x 70 mm
Conduit entries M20	8	8	8	8
Conduit entries M25	8	8	8	8
Combination	2x2	3x2	4x2	3x3
Combination conduit entries M20/25	4	4	4	4
Drilling Center max. Ø 40 mm	--	2	4	4
650 °C /	Yes / Yes	Yes / Yes	Yes / Yes	Yes / Yes
/	Yes / Yes	Yes / Yes	Yes / Yes	Yes / Yes
Art.-No.	9902.24	9902.26	9902.28	9902.29
Inner packaging/shipping	- / 12	- / 8	- / 8	- / 8

Prefix® wing set for inlet box 9902.xx



- Facilitates fixing to the reinforcement
- Fast and easy installation on opposing formwork without support element and abutment
- Holding in place using the Prefix® installation technology leaves both hands free for securing with tie wires



Length x Width x Height	150.1 x 59 x 16 mm	150.1 x 59 x 16 mm
Number of wings	4	12
650 °C	Yes	Yes
Art.-No.	9940.25	9940.50
Inner packaging/shipping	- / 5	- / 10

FLUSH-MOUNTING

CAVITY WALL

CONCRETE

HOUSINGS

FIRE PROTECTION

PLUGGABLE

CONNECTIVITY

CABLE GLANDS

TOOLS

SERVICE

Prefix® concrete construction box



- compatible with Feller SNAPFIX®
- Fast and easy installation on opposing formwork without support element and abutment
- Holding in place using the Prefix® installation technology leaves both hands free for securing with tie wires
- Several units can be securely joined together to form norm-compliant combinations
- For device screws Ø 3 mm
- Max. tightening torque 0.5 Nm

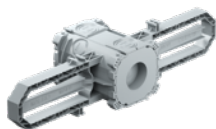

Depth	97 mm
Exit opening Ø	30 mm
Combination	1x1
650 °C /	Yes / Yes
/	Yes / Yes
Art.-No.	9940
Inner packaging/shipping	- / 10

Prefix® 2.0 concrete construction box



- compatible with Feller SNAPFIX®
- For device screws Ø 3 mm
- Max. tightening torque 0.5 Nm



	90 mm	90 mm	90 mm
Depth	90 mm	90 mm	90 mm
Combination	1x1	2x1 NUP	3x1 NUP
Break-out openings Ø 20 mm	8	16	24
Break-out openings Ø 25 mm	8	16	24
Combination conduit entries M20/25	4	4	4
Drill holes M32	4	4	4
Opening wall outlet	30 mm	30 mm	30 mm
650 °C /	Yes / Yes	Yes / Yes	Yes / Yes
/	Yes / Yes	Yes / Yes	Yes / Yes
Art.-No.	9941	9941.25	9941.35
Inner packaging/shipping	- / 15	- / 5	- / 5

Separator walls

- for separating junction casings from electrical circuit
- can be retrofitted
- Halogen-free



for casing size	180 x 180 mm	250 x 220 mm
Art.-No.	1296-20	1297-20
Inner packaging/shipping	10 / -	10 / -

Cover

- flat cover edge
- surface roughened
- countersunk for screw heads



For casing size - concrete construction boxes	128 x 128 mm	180 x 180 mm	250 x 220 mm
For casing size - flush-mounting boxes	107 x 107 mm	159 x 159 mm	238 x 208 mm
For casing size - cavity wall boxes	105 x 105 mm	165 x 165 mm	235 x 205 mm
Fireproof	850 °C	850 °C	850 °C
Art.-No.	1095-93	1096-93	1097-93
Inner packaging/shipping	10 / 500	10 / 200	5 / 100

Universal VDE cover

- for all one-gang, one-gang junction and junction boxes
- with central exit for light hook
- flat cover edge
- surface roughened



Diameter	92 mm	92 mm
Screw spacing	60 / 67 mm	60 / 67 mm
Fireproof	850 °C	850 °C
Halogen-free	-	Yes
	Yes	Yes
Art.-No.	1184-90	1184-77
Inner packaging/shipping	25 / 250	25 / 250

Universal waterproof cover

- central entry with stoppers
- for countersunk screws Ø 4 mm



Diameter	90 mm	90 mm
Screw spacing	67 mm	60 mm
Fireproof	850 °C	850 °C
Halogen-free	Yes	Yes
Art.-No.	1174-99	1174-98
Inner packaging/shipping	10 / -	10 / -

End covers and separator walls

for on-site mixed concrete

Plug-in cover

- With central plug-in connector
- For mounting wood screw Ø 3.5 mm, head Ø 6.5 - 7 mm, attach centrally in cover exit
- Screw not included



Height	5 mm
Diameter	98 mm
Colour	RAL 9010
 850 °C / 	Yes / Yes
	Yes
Art.-No.	11081
Inner packaging/shipping	- / 10

Plug-in cover with cable outlet

- With central plug-in connector
- For Art. Nos. 1245-60/-62/-63 and 1246-57
- For mounting wood screw Ø 3.5 mm, head Ø 6.5 - 7 mm, attach centrally in cover exit
- Screw not included



Height	5 mm	22 mm
Diameter	98 mm	80 mm
Colour	RAL 9010	RAL 9010
 850 °C / 	Yes / Yes	Yes / Yes
	Yes	Yes
Art.-No.	11082	11088
Inner packaging/shipping	- / 10	- / 10

Cover with mounting ring

- Can also be used as cover for reserve conduit exits
- Attach the mounting ring (included) to the exit and place the end cover in position (bayonet fitting)
- For Art. Nos. 1245-60/-62/-63 and 1246-57



Height	15 mm
Outer diameter	100 mm
Art.-No.	10100
Inner packaging/shipping	- / 10

Conduit and cable distance support

- Fixing to the formwork using expanding dowels, nails or screws
- Halogen-free



For fixing cable and conduit to formwork	Yes	-
Conduit and cable distance piece for 1270-00	-	Yes
Art.-No.	1270-00	9060-95
Inner packaging/shipping	- / 1000	1000 / 30000

Plug-in cover

- Break-out openings for cables and light fitting support hooks
- Plug-in depth min. 3 mm max. 15 mm



Diameter	35 mm	60 mm
Art.-No.	1148-93	1259-96
Inner packaging/shipping	25 / 100	25 / 250

Expanding dowel

- for quick fixing to steel formwork
- 1-piece in plastic
- for boxes, casings, bushes etc.
- drill hole size required Ø 5.5 mm



Diameter	5,5 mm
Art.-No.	1217-02
Inner packaging/shipping	500 / 2500

FLUSH-MOUNTING

CAVITY WALL

CONCRETE

HOUSINGS

FIRE PROTECTION

PLUGGABLE

CONNECTIVITY

CABLE GLANDS

TOOLS

SERVICE

Concrete construction (precast concrete)



System magnets

- The new standard in automated precast concrete
- More efficient production processes
- For a completely prefabricated electrical installation



B² one-gang junction boxes

- For magnetic and adhesive attachments
- Versions in depths of 48.5 mm, 68.5 mm and 83.5 mm
- Connection options for conduits with Ø 20 mm, Ø 25 mm, Ø 32 mm and Ø 40 mm
- 1-piece item design for quick insertion



Ceiling box

- For magnetic and adhesive attachments
- Versions in depths of 105 mm and 115 mm
- Connection options for conduits from Ø 20 mm to Ø 40 mm
- For optimum transport conditions of the slab ceilings

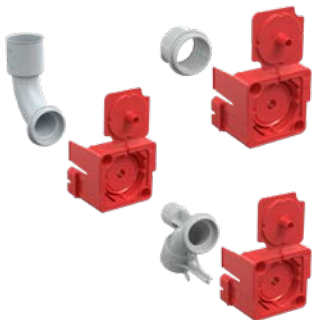

Transitions

- For magnetic and adhesive attachments
- For conduit sizes of Ø 20 mm, Ø 25 mm and Ø 32 mm
- For secure conduit connections at transitions between different components
- For uninterrupted empty conduit connections and outlets in walls and ceilings

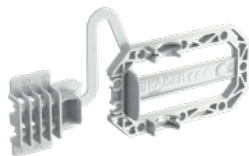

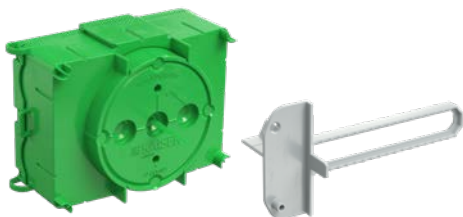

Accessories

- System accessories complement the precast concrete programme
- Conduit connectors for safe conduit connection
- Universal support and extension elements for overhead installations



System Flat 45. For prefabricated concrete garages and prefabricated concrete bathrooms

- For electrical installation in modularised, industrially produced room systems
- System installation depth 45 mm
- For use in walls from 5 cm
- Fixing to the formwork using magnets, expansion dowels, rivets and threaded screws

	<p>automated or manual production with System magnet</p>  <p>pg. 212</p>	<p>automated production as well as automated removal and storage with System magnet PLUS</p>  <p>pg. 212</p>
For installation accessories		
One-gang junction boxes		pg. 215
For cable outlets		
Luminaire installation and connection		pg. 226
Wall and ceiling transitions		
End and transition grommets		pg. 232
30° wall and ceiling transition		pg. 233

Concrete construction (precast concrete production) accessories		
Conduit connector		pg. 217
Fixing		pg. 216
Support element		pg. 223
Sealing of electrical installation conduits (air-tight and smokeproof)		pg. 32
Plaster compensation		pg. 216

System Flat 45.

The system for serially pre-assembled room modules made of concrete.

System Flat 45 Product overview		
	<p>For prefabricated concrete garages and prefabricated concrete bathrooms</p>  <p>pg. 238</p>	
For installation accessories		
One-gang box		pg. 239
One-gang junction box		pg. 239
Wall light connection box		pg. 239
Accessories		
Fastening and support elements Flat 45		pg. 240
Expanding dowel		pg. 240
Magnet		pg. 240

The KAISER product range for precast concrete

Industrially precast slab concrete elements are produced with dimensional accuracy largely using an automated precast concrete process. The high level of pre-planning, industrial prefabrication in a protected environment and automation during production with regard to the fixing and assembly of installation parts ensure short assembly times and minimised costs. The components for the electrical installation must also be fixed and integrated into the wall or ceiling with the same level of precision as is applied to their manufacture.



1 Wall and ceiling transition 90°, Oval funnel | **2** Large slab ceiling box 115 for magnet attachment | **3** HaloX® 250 with tunnel for precast concrete for magnet attachment | **4** B² one-gang junction boxes for magnet attachment | **5** B² one-gang junction box without plaster skin, depth 68.5 mm | **6** B² one-gang junction box with plaster skin, Universal extension element 175 to 300 mm | **7** End and transition grommet, wall and ceiling elbow 30°, wall and ceiling transition 90° for magnetic mounting | **8** HaloX® 180 for precast concrete for magnet attachment | **9** HaloX® 180 / 250 for precast concrete for magnet attachment | **10** HaloX® 180 with tunnel for precast concrete for magnet attachment | **11** Universal installation housing with mineral fibreboard | **12** B² one-gang junction box without plaster skin, depth 48.5 mm

Perfect connections for automated production.

The system magnet provides the basis for good installation of all electrical installation solutions in precast concrete.



Application examples



The system magnet is used to hold B² one-gang junction boxes,...



...HaloX® luminaire and loudspeaker housings,...



...wall and ceiling transition 30°, end and transition grommets...



...as well as for accommodating large slab ceiling boxes.



As well as for the new 48.5 mm extension element...



...the new wall-ceiling transitions 90°,...



...the central transition casing,...



...and the system magnet adapter for the inclined support attachment.

One system magnet for all applications.

The system magnet is suitable for all installation parts required in wall and ceiling production to prepare the electrical installation in-factory. The system magnet can be used for correct positioning in both manual and automated production. In automated production, the magnet can be placed on the formwork table automatically and in the correct position using the multifunction gripper. The PLUS system magnet can also be removed and magazined automatically.





NEW

System magnet and system magnet PLUS

The system magnet has created a new standard in automated precast concrete for efficient manufacturing processes. This means that the electrical installation can be efficiently implemented using digital planning (BIM) and can flow seamlessly into the precast concrete production process. The complete electrical installation can now be automatically integrated into the in-factory production process with the new system magnet (item no. 1299-69) or system magnet PLUS (item no. 1299-70). Regardless of whether you're using B² one-gang junction boxes, wall and ceiling transitions, large slab ceiling boxes or luminaire and loudspeaker housings, the new system magnets can be used to position everything safely and with millimetre precision. After removing the concrete formwork elements, the system magnets PLUS (item no. 1299-70) can be removed automatically.

- The complete installation can be carried out with only one type of magnet – for automated setting (system magnet, item no. 1299-69) and/or setting and removal (system magnet Plus, item no. 1299-70)
- Four sideway notches ensure torsion-proof installation of the one-gang boxes
- Reusable

 INNOVATION



System magnet

- for accurate positioning during automated or manual production
- with an anti-twist device for one-gang boxes
- adhesive force 500 N (50 kg)
- Can be used for the following articles:
- HaloX® installation housing / item no. 1282-74/-75/-76 and 1283-74/-76
- B² one-gang junction boxes / item no. 1262-06, 1263-06, 1264-06
- 115 large slab ceiling box / item no. 1227-16
- End and transition bushes / item no. 1261-82/-83/-84
- Wall and ceiling transitions 30° / item no. 1261-92/-93/-94

NEW

 INNOVATION



Art.-No.

1299-69

Inner packaging/shipping

- / 10

System magnet PLUS

NEW

INNOVATION



3D animation

- for correct positioning during automated production as well as automated removal and storage
- with an anti-twist device for one-gang boxes
- adhesive force 500 N (50 kg)
- Can be used for the following articles:
- HaloX® installation housing / item no. 1282-74/-75/-76 and 1283-74/-76
- B² one-gang junction boxes / item no. 1262-06, 1263-06, 1264-06
- 115 large slab ceiling box / item no. 1227-16
- End and transition bushes / item no. 1261-82/-83/-84
- Wall and ceiling transitions 30° / item no. 1261-92/-93/-94



Art.-No.	1299-70
Inner packaging/shipping	- / 10

Magnet

- for clamp attachment in the box
- for anti-shock fixing of one-gang junction boxes in horizontal formwork
- Adhesive force of 900 N (90 kg)
- Magnet remains on the formwork table after formwork removal
- Centering device for correct positioning during automated production



Art.-No.	1261-81
Inner packaging/shipping	- / 5

FLUSH-MOUNTING

CAVITY WALL

CONCRETE

HOUSINGS

FIRE PROTECTION

PLUGGABLE

CONNECTIVITY

CABLE GLANDS

TOOLS

SERVICE

B² one-gang junction boxes

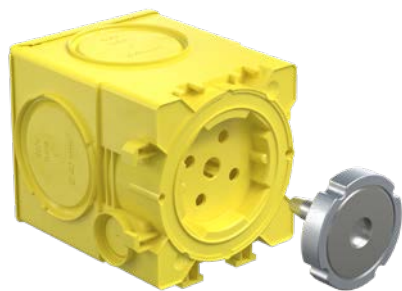

NEW

The new B² one-gang junction boxes for precast concrete offer plenty of space for terminals and cables thanks to their large volume and ease of assembly. The version with a slot for the system magnets (Art.-Nr. 1299-69) or system magnet PLUS (Art. No. 1299-70) is perfect for quick attachment to system magnets that have already been set automatically. Multiple combinations with a standardised combination distance of 71 mm can be created quickly and easily using the connection options on the side of the B² one-gang junction boxes. The separately available conduit connectors for toolless conduit connection prevent concrete from flowing in and, at the same time, dampen conduit vibrations during the compaction process.

- For in-factory installation
- Slot for system magnet (Art.-No. 1299-69) and system magnet PLUS (Art.-No. 1299-70)
- 4 screw domes and 2 expanding claw fields for accessory fitting
- Standardised combination distance 71 mm
- 1-piece

INNOVATION



Fixing variant

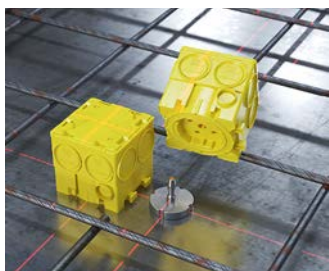

B² one-gang junction boxes with holder for KAISER system magnets (Art. No. 1299-69 / 1299-70).

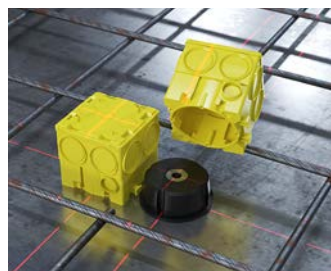

B² one-gang junction boxes without plaster skin with holder for the magnet (Art. No. 1261-81).

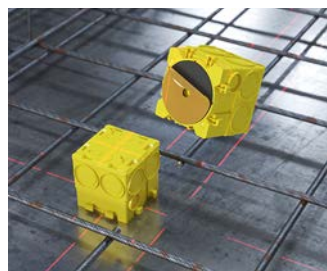

B² one-gang junction boxes with plaster skin to hold the adhesive foil (Art. No. 1219-00)...



...or by means of hot glue.

Product advantages



The conduit connectors buffer the vibrations that occur between the conduit and the box during the compression process...

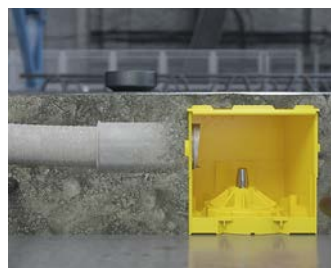

...and at the same time securely seal the connection in any position.

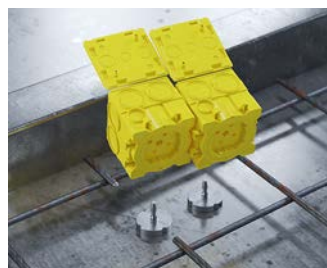

Combination of two B² one-gang junction boxes...



...fixed to the steel formwork using a system magnet.

B² one-gang junction boxes

- for in-factory installation
- Slot for system magnet (Art.-No. 1299-69) and system-magnet PLUS (Art.-No. 1299-70)
- 1-piece
- 4 screw domes and 2 expanding claw fields for accessory fitting
- Standardised combination distance 71 mm

NEW

INNOVATION



3D animation



Depth	48,5 mm	68,5 mm	83,5 mm
Installation opening Ø	60 mm	60 mm	60 mm
Markings for wires and cables up to Ø 16 mm	4	4	2
Break-out openings for DIN EN Ø 20/25 mm conduits	4	8	-
Break-out openings for DIN EN Ø 32/40 mm conduits	-	-	4
/	Yes / Yes	Yes / Yes	Yes / Yes
Art.-No.	1262-06	1263-06	1264-06
Inner packaging/shipping	- / 100	- / 100	- / 100

B² one-gang junction box without plaster skin

- for in-factory installation
- Fixing to the formwork by means of KAISER B² magnet (Art. No. 1261-81)
- 4 screw domes and 2 expanding claw fields for accessory fitting
- Standardised combination distance 71 mm
- 1-piece



Depth	48,5 mm	68,5 mm	83,5 mm
Installation opening Ø	60 mm	60 mm	60 mm
Markings for wires and cables up to Ø 16 mm	4	4	2
Break-out openings for DIN EN Ø 20/25 mm conduits	4	8	-
Break-out openings for DIN EN Ø 32/40 mm conduits	-	-	4
/	Yes / Yes	Yes / Yes	Yes / Yes
Art.-No.	1262-61	1263-61	1264-61
Inner packaging/shipping	- / 100	- / 100	- / 100

One-gang junction boxes and system components

for horizontal precast concrete

B² one-gang junction box with plaster skin

- for in-factory installation
- Fastening to the formwork by means of KAISER adhesive foil (Art. No. 1219-00) or hot glue
- 4 screw domes and 2 expanding claw fields for accessory fitting
- Standardised combination distance 71 mm
- 1-piece



Depth	48,5 mm	68,5 mm	83,5 mm
Installation opening Ø	60 mm	60 mm	60 mm
Markings for wires and cables up to Ø 16 mm	4	4	2
Break-out openings for DIN EN Ø 20/25 mm conduits	4	8	-
Break-out openings for DIN EN Ø 32/40 mm conduits	-	-	4
/	Yes / Yes	Yes / Yes	Yes / Yes
Art.-No.	1262-60	1263-60	1264-60
Inner packaging/shipping	- / 100	- / 100	- / 100

Distance piece 142

- for connecting to all one-gang junction boxes at 142 mm centre distance
- for separate covering, e.g. low-voltage in combinations with sockets without electric shock protection
- also for overhead boxes
- with push-button connection for extension elements

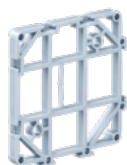

Art.-No.	1261-18
Inner packaging/shipping	- / 50

Plaster compensation ring

- for latching on the one-gang junction box
- screw distance to accessory fixing 60 mm
- with moulded-in plaster skin to prevent ingress of cleaning material



Height	14,5 mm
Diameter	60 mm
Art.-No.	1261-60
Inner packaging/shipping	25 / 250

B² conduit connectors

The range of B² conduit connectors offers a secure and toolless conduit connection to the B² one-gang junction boxes without the need for special tools. The conduit connection created using a conduit connector is absolutely impermeable to concrete and safely dampens the vibrations of the conduits during the compaction process. As the conduit connection is made outside the B² one-gang junction boxes, no conduit protrudes into the interior of the box, thus eliminating the need to shorten the conduit on the inside. With the new 90° conduit connectors, sideways conduit connections can now also be easily implemented in narrow installation areas.

- Toolless conduit connection, no special tools required
- Precisely fitting „variable“ conduit connection, absolutely sealed against concrete
- Damping of vibrations during the high-frequency or low-frequency compression process
- Conduit connection outside the one-gang junction box, no conduits protruding into the interior of the box
- Conduit connectors 90° for the lateral connection of conduits in narrow installation areas



NEW



3D animation



Secure and fast connections using KAISER conduit connectors

With the extensive KAISER conduit connector programme, all rigid or flexible conduits in diameters of 20, 25, 32 and 40 mm can be connected to the B² one-gang junction boxes. Two cutting edges on the connection piece are used to open the box entries without the need for tools; all that is needed to open the entry is to turn it with pressure against the box.

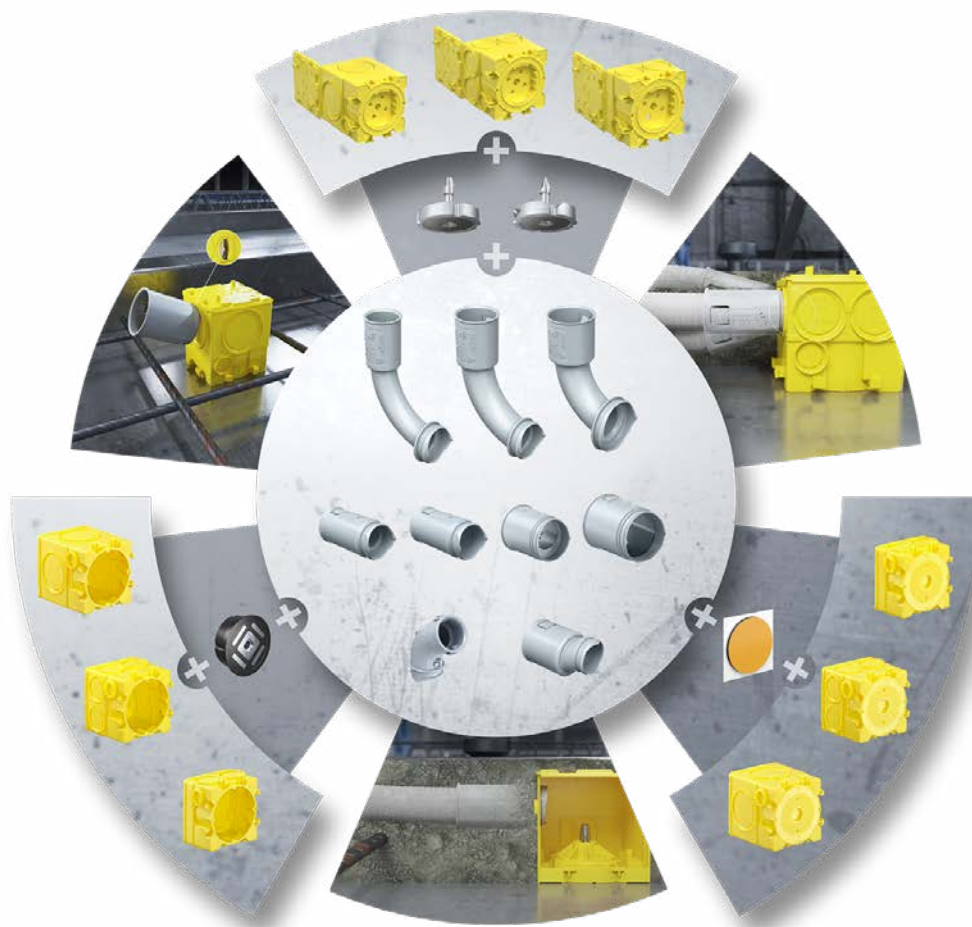

B² conduit connectors

for horizontal precast concrete

Application examples



B² conduit connectors with integrated conduit lock for flexible as well as rigid conduits Ø 20/25/32/40 mm.



Insert the tips of the conduit connector into the desired conduit entry...



...and using pressure, turn against the one-gang junction box until the feed-through is cut out.



Straight conduit connectors as well as 90° and 60° versions enable every conceivable conduit connection.

Processing instructions / prefabrication



The B² range, consisting of one-gang junction boxes, conduit connectors and wall/ceiling transitions, enables complete pre-assembly of the electrical installation. For this...



...the conduit connectors and wall/ceiling transitions offer the greatest possible tolerance compensation when using rigid conduits.



The planned sub-assemblies for the respective concrete wall elements can be prefabricated in the factory to fit precisely and on time...



...and then simply and quickly positioned on the formwork table in the circulation system without unnecessarily burdening the production process.

Conduit connector

- Toolless conduit connection to the B² one-gang junction boxes
- Accepts rigid and flexible conduits
- Damping of conduit vibrations during the compaction process
- Prevents the conduits penetrating the one-gang junction box and thus prevents conduits from being shortened later on
- Art.-Nr. 1261-21 replaces Art. No. 1261-20 and Art. No. 1261-26 replaces Art. No. 1261-25

NEW



Product-Data

DIN EN conduit Ø	20 mm	25 mm	32 mm	40 mm
Art.-No.	1261-21	1261-26	1261-32	1261-40
Inner packaging/shipping	- / 100	- / 100	- / 100	- / 100

Conduit connectors Ø 20/25/32/40 mm



With built-in conduit lock designed especially for corrugated conduits as well as rigid conduits with a diameter of Ø 20/25/32/40 mm.



The tip of the conduit connector is inserted at the marking.



Using pressure, the conduit connector is turned against the one-gang junction box until the feed-through is cut out.



Snap in the conduit connector and insert the conduit into the conduit connector.

Conduit transition coupling Ø 32 mm

NEW

- For toolless connection of Ø 32 mm conduits to the B² one-gang junction boxes 1262-XX and 1263-XX
- Accepts rigid and flexible conduits
- Damping of conduit vibrations during the compaction process
- Prevents the conduits from penetrating the B² one-gang junction boxes and thus avoids subsequent conduit shortening



DIN EN conduit Ø	32 mm
Art.-No.	1263-32
Inner packaging/shipping	- / 100

Conduit transition coupling Ø 32 mm – Application examples



With built-in conduit lock designed especially for corrugated conduits with a diameter of 32 mm.



Push the nose of the conduit transition coupling at the marking of the box and turn it with pressure against the B² one-gang junction box until the feed-through is cut out.



The conduit transition coupling directs the inner diameter of the conduit unrestricted into the B² one-gang junction boxes Art. No. 1262-XX and 1263-XX...



...and thus enables the secure conduit connection of two Ø 32 mm conduits from one direction.

90° conduit connector

NEW

- Toolless conduit connection to the B² one-gang junction boxes
- Accepts rigid and flexible conduits
- Damping of conduit vibrations during the compaction process
- Prevents the conduits penetrating the one-gang junction box and thus prevents conduits from being shortened later on
- Easy cable pull-in thanks to optimised 90° conduit elbow



DIN EN conduit Ø	20 mm	25 mm	32 mm
Art.-No.	1262-20	1262-25	1262-32
Inner packaging/shipping	- / 100	- / 100	- / 100

Conduit connector 90° – Application examples



Pierce the tip of the conduit connector 90° at the marking and turn it with pressure against the B² one-gang junction box until the feed-through is cut out.



Insert the conduit in engaged 90° conduit connector.



The 90° conduit connectors enable the lateral connection of conduits even in tight installation areas...

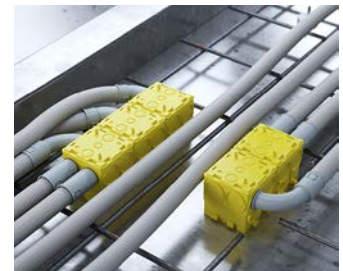

...for both flexible and rigid conduits.

60° conduit connector

- space-saving entry of conduits in confined spaces, e.g. door and window areas
- for punching out markings without tools
- for fitting flexible 25 mm DIN EN conduits



Art.-No.	1266-25
Inner packaging/shipping	- / 100

Conduit connector 60° / diameter 25 mm



Snap the two halves of the 60° conduit connector together.



Pierce the tip of the 60° conduit connector at the desired conduit entry and turn until the feed-through is cut out.



Insert the conduit in engaged conduit connector 60°.



3-unit combination with inserted conduits in the wall area.

48.5 mm extension element for system magnet

The new 48.5 mm extension element for precast concrete enables automated positioning and fixing of overhead electrical installations in solid concrete walls as well as double concrete walls. The integrated slot for the system magnets (Art. No. 1299-69) and system magnet PLUS (Art. No. 1299-70) offers a safe, formwork-flush fit on the horizontal steel formwork for the circulation systems used in the concrete plants. At the same time, the tried-and-tested B² push-button connection ensures a secure connection to all B² one-gang junction boxes and B² extension elements and thus enables overhead installation from a wall thickness of 100 mm.

- Slot for system magnet (Art.-No. 1299-69) and system magnet PLUS (Art.-No. 1299-70)
- For use in automated production lines
- Push-button connection to all B² one-gang junction boxes and B² extension elements
- Can be combined with itself, the B² one-gang junction boxes and distance piece 142
- Integrated closing cap to protect the rear of the system magnet from concrete
- Spacers at the front ensure complete flow around the recess
- After formwork removal, the system magnet remains on the formwork table



NEW



Processing instructions



The fixing of 48.5 mm extension element (Art. No. 1261-02) for use in automated production lines is carried out via...



...the system magnets (Art. No. 1299-69 or 1299-70) and thus provides the precisely aligned and secure basis for overhead installation.



By putting on the integrated closing cap, the interface of the system magnet is protected from concrete on the rear side.



Peripheral sealing lips protect the system magnet from the inflowing concrete on the front side, while the external spacers allow the concrete to completely flow around the recess at the same time.



The connection between the extension element and B² one-gang junction boxes is made via the proven B² push-button connection.



The 48.5 mm extension element can be combined with itself, the B² one-gang junction boxes and the distance piece 142 (Art. No. 1261-18).



In combination with the extension element 10 to 50 mm (Art. No. 1261-10) and the universal extension elements 105 - 170 mm (Art. No. 1261-08)...



...and/or 175 - 300 mm (Art. No. 1261-09), overhead installations can be realised in all wall element thicknesses.

Extension element for system magnet

for horizontal precast concrete

48.5 mm extension element for system magnet

NEW

INNOVATION



3D animation

- for installation of overhead B² one-gang junction boxes
- Slot for system magnet (Art.-No. 1299-69) and system magnet PLUS (Art.-No. 1299-70)
- Standardised combination distance 71 mm
- Can be used for the following articles:
 - B² one-gang junction boxes / Art. No. 1262-XX, 1263-XX, 1264-XX
 - 10 – 50 mm extension element / Art. No. 1261-10
 - Universal extension elements / Art. no. 1261-08/-09
 - Flat 45 one-gang box / Art. No. 1256-01
 - Flat 45 one-gang junction box / Art. No. 1266-01
 - Flat 45 wall light connection box / Art. No. 1246-01
- Can be combined with the following items:
 - B² one-gang junction box / Art. No. 1262-XX, 1263-XX, 1264-XX
 - B² distance piece 142 / Art. No. 1261-18



Vertical installation height	48,5 mm
Art.-No.	1261-02
Inner packaging/shipping	- / 100

Application examples – 48.5 mm extension unit

Simple and safe adjustment to the required wall thickness for solid wall elements and for double walls.

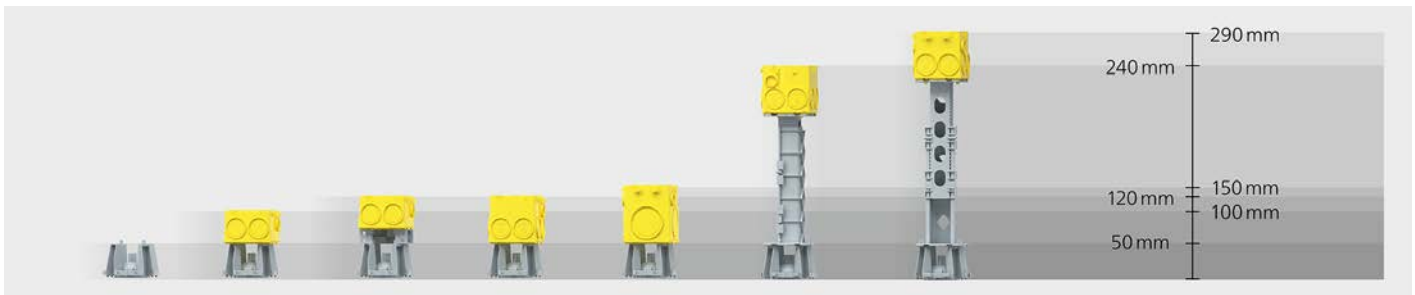

Extension element 10/50 mm

Extension element for bridging wall thicknesses and supporting one-gang boxes during installation on the opposing formwork. Bridging of up to 100 mm (plus box dimensions) can be underpinned securely in increments of 10 or 50 mm.

- For installation of overhead one-gang junction boxes
- Fitting height: vertical 50 mm, horizontal 10 mm
- can be attached to one-gang junction boxes or abutment using push-stud conduit connector
- Clip the connector into place, insert the conduit into the connector.

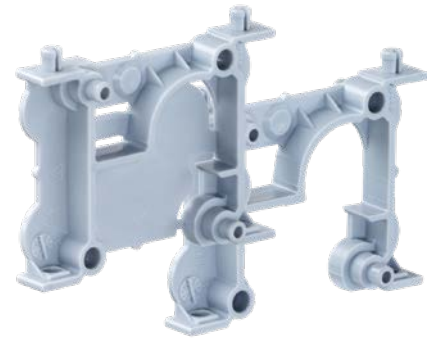

Processing instructions



Connected crossways, the elements provide stable and non-distorting support.



A wide range of possibilities for adjusting the installation height.

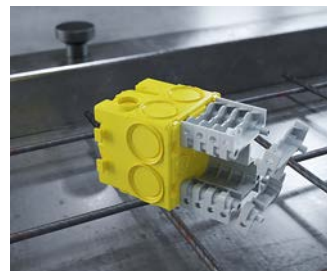

Different installation heights can be created in 10 mm or 50 mm increments.

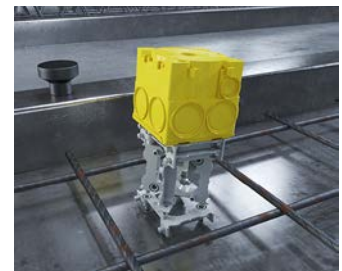

The abutment is required as an initial element on the switch table for overhead boxes and can be connected to extension elements and one-gang junction boxes.

Extension element 10/50 mm

- for fitting of overhead one-gang junction boxes at greater heights
- can be attached to one-gang junction boxes or abutment using push-stud conduit connector



Installation heights, horizontal	10 mm
Installation heights, vertical	50 mm
Art.-No.	1261-10
Inner packaging/shipping	- / 50

Abutment

- for fitting of overhead one-gang junction boxes at greater heights
- for fixing to formworks



Art.-No.	1261-11
Inner packaging/shipping	- / 50

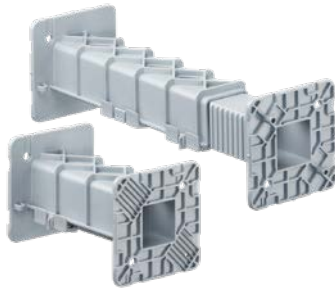

Universal extension element from 105 mm

Universal extension element for bridging wall thicknesses of more than 105 mm and supporting one-gang boxes during installation on the opposing formwork. Thanks to the various sizes, heights of 105 mm up to 300 mm (plus box dimensions) can be bridged in increments of 5 mm.

- For installation of overhead one-gang junction boxes
- Height adjustable in increments of 5 mm
- Can be attached to one-gang junction boxes using push-button connection



Processing instructions

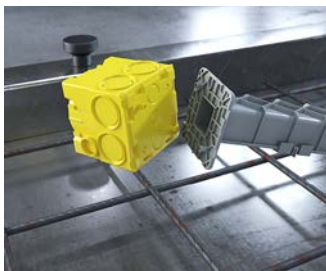

Connect the universal extension element and the B² one-gang junction box using the push-button connection.



Attach the universal extension element to the formwork table with hot glue.



The correct height is achieved by simply assembling the two halves.



Opposite, B² one-gang junction boxes installed with universal extension element.

Note

For lengths of less than 105 mm, the two parts are simply shortened and put back together again.

Universal extension element

- for fitting of overhead one-gang junction boxes at greater heights
- height adjustable in increments of 5 mm

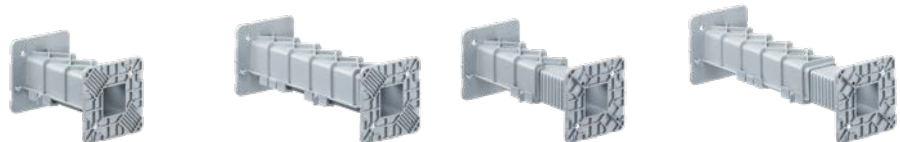

Length (+ box installation height)	105 - 170 mm	175 - 300 mm	105 - 170 mm	175 - 300 mm
attached using hot glue	Yes	Yes	-	-
can be attached with push-stud conduit connector	-	-	Yes	Yes
Art.-No.	1261-06	1261-07	1261-08	1261-09
Inner packaging/shipping	- / 50	- / 50	- / 50	- / 50

System magnet adapter for the inclined support fixing

In addition to the electrical installation components in concrete wall production, there are new system magnet adapters for the automated integration of the mounting dowels for installing the wall elements on the construction site into the factory production process. These are matched to the available inclined support attachments on the market and thus enable the complete factory integration of all components required for a wall element.

- Patented system magnet locking mechanism for a secure fit on the system magnet when an inclined support attachment is attached
- Easy placement on the system magnets and simple removal after formwork removal
- Secure and concrete-tight connection to the mounting dowel
- Tapered contour for the adapter to remain securely on the formwork table



NEW

INNOVATION

Application examples



Thanks to the innovative system magnet lock, the adapter can be easily attached to and removed from the system magnets (Art. No. 1299-69 / 1299-70).



As soon as the mounting dowel is placed on the adapter, the system magnet locking mechanism engages,...

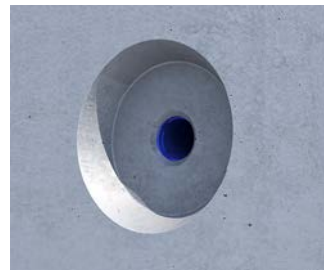

...so that the adapter remains securely on the magnets after formwork removal, also thanks to its conical contour.

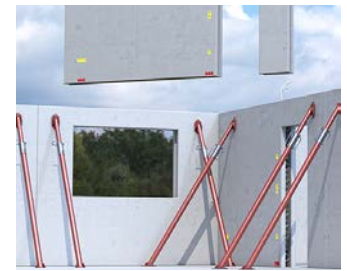

At least two mounting dowels are required for each wall element when installing the concrete wall elements.

System magnet adapter for the inclined support attachment

NEW

INNOVATION

- For the automated and precise positioning of all commercially available inclined support attachments or assembly dowels
- Slot for system magnet (Art.-No. 1299-69) and system magnet PLUS (Art.-No. 1299-70)



For manufacturers	On request
Art.-No.	1200-99
Inner packaging/shipping	- / 200



NEW

Large slab ceiling box

The large slab ceiling box is suitable for in-factory installation in prefabricated ceilings. The version with a slot for the system magnet (Art. No. 1299-69) or system magnet PLUS (Art. No. 1299-70) is ideally suited for quick attachment to system magnets that have already been set automatically. The large slab ceiling boxes are already a part of the ceiling when they reach the construction site and enable the quick insertion of empty conduits. The resealable quick-release cover can be opened with a quarter turn and so enables the quick and exact creation of conduit entries using punch pliers (Art. No. 1286-33/-34).

- For in-factory installation
- Slot for system magnet (Art.-No. 1299-69) and system magnet PLUS (Art.-No. 1299-70)
- Large adhesive area with rough surface structure for a secure fit on the formwork table
- 115-mm installation height guarantees optimal transport conditions for prefabricated ceilings
- Quick-release cover for fast cutting of conduit entries using punch pliers
- Integrated M5 domed cap nut ensures secure fitting of a light hook.
- With closing cover for on-site fitting of conduits

INNOVATION

Processing instructions



Large slab ceiling box fixed to steel table by means of system magnet.



Quick-release cover for fast cutting of conduit entries using punch pliers.



8 markings for entries up to Ø 25 mm for easy creation of cable or pipe entries above the filigree ceiling element.



M5 metal nut for secure mounting of light hooks up to 100 N (10 kg) according to DIN EN 60670.

Large slab ceiling box 115

- For in-factory installation
- Slot for system magnet (Art.-No. 1299-69) and system magnet PLUS (Art.-No. 1299-70)
- Installation height 115 mm, with M5 metal nut for light hook (min. hook length: 115 mm + plaster thickness)
- With closing cover for on-site fitting of conduits
- maximum light hook load according to DIN EN 60670 100 N (10 kg)

NEW

INNOVATION



3D animation



Depth	115 mm
Exit opening Ø	60 mm
Markings for wires and cables up to Ø 25 mm	8
Markings for wires and cables up to Ø 32 mm	4
Number of parts	2
	Yes
Art.-No.	1227-16
Inner packaging/shipping	- / 100

Large slab ceiling box 115

- for in-factory installation
- Fastening to the formwork by means of KAISER adhesive foil (Art. No. 1219-00) or hot glue
- Installation height 115 mm, with M5 metal nut for light hook (min. hook length: 115 mm + plaster thickness)
- With closing cover for on-site fitting of conduits
- maximum light hook load according to DIN EN 60670 100 N (10 kg)



Large slab ceiling box 105

- for in-factory installation
- Fastening to the formwork by means of KAISER adhesive foil (Art. No. 1219-00) or hot glue
- Installation height 105 mm, with metal nut M5 for light hook (min. hook length: 105 mm + plaster thickness)
- for space frame heights up to 11 cm (incl. distance pieces)
- With closing cover for on-site fitting of conduits
- maximum light hook load according to DIN EN 60670 100 N (10 kg)



Depth	115 mm	105 mm
Exit opening Ø	60 mm	60 mm
Markings for cables and DIN EN conduits up to Ø 25 mm	8	8
Markings for cables and DIN EN conduits up to Ø 32 mm	4	-
Number of parts	2	2
especially suitable for hot glue attachment	Yes	Yes
	Yes	Yes
Art.-No.	1227-55	1227-54
Inner packaging/shipping	- / 100	- / 100

Light hook

- For retrofitting in ceiling boxes (EN 60670)
- maximum light hook load according to DIN EN 60670 100 N (10 kg)
- with M5 thread, fully insulated



Length of shank	105 mm	115 mm	125 mm
Diameter hook	26 mm	26 mm	26 mm
Overall length	132 mm	143 mm	151 mm
Thread length	10 mm	10 mm	10 mm
Art.-No.	1226-97	1226-98	1226-99
Inner packaging/shipping	- / 100	- / 100	- / 100



NEW

Central transition casing

The new central transition box for use in in-situ concrete ceilings or factory prefabricated element ceilings is used for the central connection of conduits of different diameters. As a central feed-in point, it enables a clean transition to circuit distribution boxes and cable routing systems, allowing, for example, all the supply cables required for the electrical installation of a flat to be brought together at one transition point.

- For leaving out several cables, e.g. above an electrical distribution board located in the lightweight wall or surface-mounted
- For system magnetic, adhesive or nail fastening
- Conduit entries for \varnothing 20 mm, \varnothing 25 mm and \varnothing 32 mm on the long sides, up to \varnothing 63 mm on the short sides
- Positioning of the conduit entries above the first reinforcement layer or the top of the filigree ceiling
- Can be connected in a row as often as required



Application examples



Numerous entries for conduits from \varnothing 20 mm to \varnothing 63 mm.



The central transition casing for the exit of several conduits, e.g. is located in above in the lightweight wall...

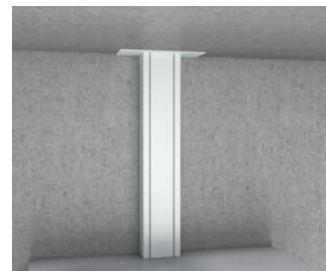

...or surface-mounted electrical distribution...

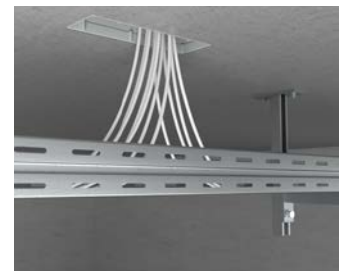

...as well as cable routing systems.

Processing instructions



Fixing by means of KAISER system magnet (Art. No. 1299-69) or KAISER system magnet PLUS (Art. No. 1299-70).



Fixing by means of hot glue.

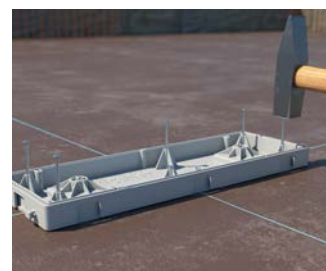

Fixing by means of steel nails.



If required, several central transition casings can be lined up next to each other.

Installation



The fixing of the central transition casing (Art. No. 9914.10) for use in automated production systems...

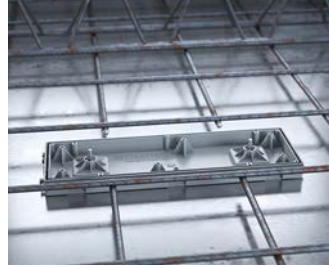

...is achieved using the KAISER system magnets (Art. No. 1299-69 or 1299-70).



Latch the centre transition casing onto the front section.



After curing, the prefabricated ceiling formwork is removed and prepared for transport to the construction site.



The required conduit entries can be opened with the KAISER step drill (Art. No. 1284-32)...



...or opened with a screwdriver and hammer.



The side entries \varnothing 40 mm to \varnothing 63 mm can be drilled out using a hole saw.



Numerous entries for conduits from \varnothing 20 mm to \varnothing 63 mm.



Open the plaster skin with a hammer and, if necessary, with a screwdriver.



The upper frame (Art. No. 9914.10.68) can be used for suspended ceiling insulation. Multiple times if required.



The plastic screw cover (Art. No. 9914.10.02) with six screws supplied is available for a clean room separation...



...or the wet lid made of aluminium (Art. No. 9914.10.03) with anodised surface and six stainless steel screws supplied.

Central transition casing

for precast concrete

Central transition casing

- For system magnetic, adhesive or nail fastening
- Conduit entries for Ø 20 mm, Ø 25 mm and Ø 32 mm on the long sides, up to Ø 63 mm on the short side
- The conduit entries are located above the first reinforcement layer or the top of the filigree ceiling

NEW



INNOVATION



3D animation



Product-Data

Length x Width x Depth	326 x 104 x 118 mm
Combination conduit entries M20/25	24
Combination conduit entries M25/32	6
Combination conduit entries M40/50/63	2
Extensive pull-out apertures	4
Number of nails	6
/	Yes / Yes
CE	Yes
Art.-No.	9914.10
Inner packaging/shipping	- / 10

Screw-in and moisture-proof cover ALU for central transition casing

NEW



INNOVATION

Length x Width x Height	330 x 120 x 5 mm	330 x 120 x 4 mm
Colour	RAL 9010	-
Screws	6	6
For type number	9914.10	9914.10
/	Yes / Yes	-
CE	Yes	-
Art.-No.	9914.10.02	9914.10.03
Inner packaging/shipping	- / 150	- / 50

Upper frame for central transition casing

NEW



INNOVATION

Length x Width x Depth	308 x 98 x 45 mm
For type number	9914.10
/	Yes / Yes
CE	Yes
Art.-No.	9914.10.68
Inner packaging/shipping	- / 5

Wall and ceiling transitions

For the first time, the new end and transition grommets, 30° wall and ceiling elbows, and 90° wall and ceiling transitions allow the automated positioning and fastening of conduit connections in precast concrete elements. The integrated slot for the system magnets (Art. No. 1299-69) and system magnet PLUS (Art. No. 1299-70) enables a safe, formwork-flush fit on the horizontal steel formwork for the circulation systems used in the concrete plants. The new items also provide alternative options for fixing to formwork. They can be fixed using hot glue, steel nails and even for overhead installation in solid wall elements using Prefix® Universal supports (Art. No. 1261-00).

- Slot for system magnet (Art. No. 1299-69) and system magnet PLUS (Art. No. 1299-70) for use in automated production lines
- For conduit sizes of Ø 20 mm, Ø 25 mm and Ø 32 mm
- All end and transition grommets, wall and ceiling elbows 30° and wall and ceiling transitions 90° can be combined with each other
- Resealable sealing cover to protect the empty conduit system from concrete when installed on top, during transport and when erected on site
- Signal bristle and bold colouring for easy retrieval in the concrete surface
- Optimal elbow radius for easy cable insertion
- 1-part design, immediately ready for use



NEW



3D animation

INNOVATION

Application examples



Wall and ceiling transitions with slot for the KAISER system magnet (Art. No. 1299-69) and system magnet PLUS (Art. No. 1299-70).



Wall and ceiling transitions for fixing by means of hot glue.



For mounting on the working formwork – two sturdy nail domes with nail pre-fixing enable a secure hold on the formwork with steel nails.



Prefix® universal support (Art. No. 1261-00) – Simple and fast processing for overhead installations.

Processing instructions



Re-closable closing cover – Protection from concrete during transport and when erecting the wall element on the construction site.



Signal bristle – Easy locating of the transition in the wall surface



The new elbows can be combined in the best possible way and can therefore be processed quickly and precisely.

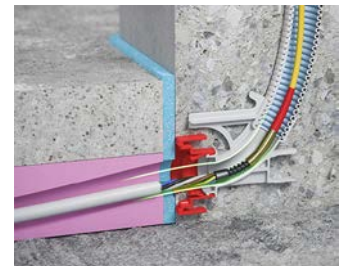

The optimal elbow radius of the new unit facilitates flexible and easy cable insertion.

One-gang junction boxes and system components

for horizontal precast concrete

Processing instructions - Pre-assembly



The B² range, comprising one-gang junction boxes, conduit connectors and wall/ceiling transitions enables complete pre-assembly of the electrical installation.



The conduit connectors and wall/ceiling transitions offer the greatest possible tolerance compensation when using rigid conduits.



The planned sub-assemblies for the respective concrete wall elements can be prefabricated in the factory to fit precisely and on time.



These can then be positioned on the formwork table quickly and easily in the circulation system without unnecessarily burdening the production process.

End and transition grommets

- For connecting conduits at transition points
- Slot for system magnet (Art.-No. 1299-69) and system magnet PLUS (Art.-No. 1299-70)
- Large adhesive surface
- For overhead installation in solid walls
- With closing cover to prevent ingress of foreign bodies
- Combinable end and transition grommets and wall and 30° ceiling transition
- Two slots for Prefix® system accessories
- Suitable for all types of formwork
- Two nail domes



INNOVATION



Product-Data

Length x Width x Depth	53 x 64 x 48 mm	53 x 64 x 48 mm	53 x 64 x 49 mm
DIN EN conduit Ø	20 mm	25 mm	32 mm
Number of parts	2	2	2
Art.-No.	1261-82	1261-83	1261-84
Inner packaging/shipping	- / 100	- / 100	- / 100

30° wall and ceiling transition

INNOVATION



Product-Data

- For connecting conduits at transition points
- Slot for system magnet (Art.-No. 1299-69) and system magnet PLUS (Art.-No. 1299-70)
- Large adhesive surface
- For overhead installation in solid walls
- With closing cover to prevent ingress of foreign bodies
- Combinable end and transition grommets and wall and 30° ceiling transition
- Two slots for Prefix® system accessories
- Suitable for all types of formwork
- Two nail domes



Length x Width x Depth	80 x 64 x 86,5 mm	81 x 64 x 86,5 mm	86 x 64 x 91 mm
DIN EN conduit Ø	20 mm	25 mm	32 mm
Number of parts	2	2	2
Art.-No.	1261-92	1261-93	1261-94
Inner packaging/shipping	- / 100	- / 100	- / 100

90° wall and ceiling transitions

NEW

INNOVATION



Product-Data

- For connecting conduits at transition points
- Slot for system magnet (Art.-No. 1299-69) and system magnet PLUS (Art.-No. 1299-70)
- Large adhesive surface
- Ideally suited for the construction of a rigid conduit system
- For overhead installation in solid walls
- With closing cover to prevent ingress of foreign bodies
- Can be combined with end and transition grommets and 30° wall and ceiling bends
- Two slots for Prefix® system accessories
- Suitable for all types of formwork
- Two nail domes



Length x Width x Depth	105 x 64 x 78 mm	105 x 64 x 80,5 mm	105 x 64 x 84 mm
DIN EN conduit Ø	20 mm	25 mm	32 mm
Number of parts	2	2	2
Art.-No.	1261-95	1261-96	1261-97
Inner packaging/shipping	- / 100	- / 100	- / 100

FLUSH-MOUNTING

CAVITY WALL

CONCRETE

HOUSINGS

FIRE PROTECTION

PLUGGABLE

CONNECTIVITY

CABLE GLANDS

TOOLS

SERVICE

Prefix® universal support

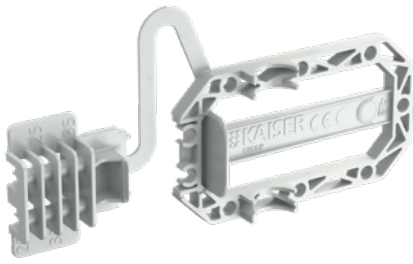

NEW

The Prefix® universal support enables simple, fast fitting of electrical installations in solid wall elements on the opposing formwork side without a support element for the steel formwork table. The support can be easily adjusted to the required concrete ceiling by means of a snap-in connection and attached to the new end and transition bushes, wall and ceiling transitions 30° and wall and ceiling transitions 90° by means of a snap-in connection. The previously customary and costly in-house constructions using timber blanks can thus be dispensed with, disruptions to the further production process are a thing of the past and production of a good wall surface quality is guaranteed without restriction.

- For overhead electrical installations in prefabricated solid walls without support elements
- With integrated dimension indication, easily adjustable to the common concrete ceilings 20 mm, 25 mm, 30 mm or 35 mm
- Generous tolerance compensation for fixing to the reinforcement
- Prefixing using Prefix® installation technology leaves both hands free for fixing with tie wires

INNOVATION

Fitting instructions

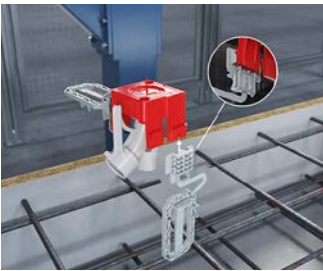

The new wall and ceiling transitions for factory production each have two opposing stable slots for the Prefix® universal support.



The required concrete ceiling can be quickly read off and precisely set using the dimensional scale. The dimensional scale is adjusted, so that the wall-ceiling transitions are minimally below the subsequent wall surface,

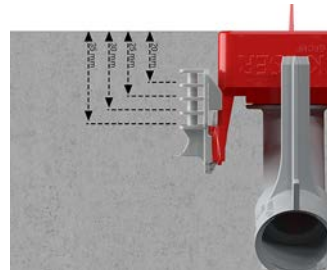

and therefore do not impede the next steps in the manufacturing process. The signal bristle keeps the position of the exits visible in the concrete surface.

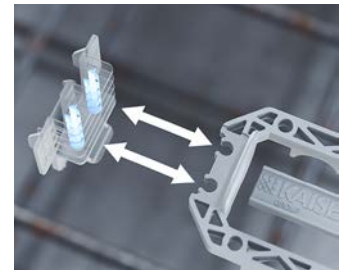

Prefix® universal supports have a stable snap-in connection and can be released and repositioned if the concrete ceiling is set incorrectly.

Prefix® universal support

- For electrical installations on the opposing formwork side.
- Facilitates fixing to the reinforcement
- Adjustable to concrete ceilings 20, 25, 30 or 35
- Pre-fixing by means of Prefix® installation technology
- Can be used for the following articles:
- End and transition bushes / item no. 1261-82/-83/-84
- Wall and ceiling transitions 30° / item no. 1261-92/-93/-94
- Wall and ceiling transitions 90° / item no. 1261-95/-96/-97

NEW

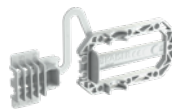

INNOVATION

Length x Width x Height	87 x 45 x 36 mm
Number of parts	1
for concrete covers	20, 25, 30, 35 mm
Art.-No.	1261-00
Inner packaging/shipping	- / 350

Wall and ceiling transition

Wall and ceiling transition for uninterrupted conduit connections and wall and ceiling exits. The exact distance to the formwork edgings can be set and fixed in 5 mm increments with the integrated measurement strip.

- For secure conduit connections on prefabricated concrete elements
- For fitting to formwork edging
- For rigid and flexible DIN EN conduits Ø 25 mm
- For locating exact height thanks to integrated measurement strip



Installation



The exact position is achieved with the help of the measurement strip and by gluing it to the formwork edging.



The moulded closing cover protects the opening against dirt and concrete. Simply open it prior to installation.



Insert the conduit into the clean installation opening.



Wall exit of a prefabricated wall as transition to the filigree ceiling.

Wall and ceiling transition

- for fitting to formwork edging
- with moulded-in measurement strip to achieve the exact installation height in 5 mm steps
- with closing cover to prevent ingress of material



DIN EN conduit Ø	25 mm
Art.-No.	1261-12
Inner packaging/shipping	- / 100

One-gang junction boxes and system components

for horizontal precast concrete



90° wall and ceiling transition

90° wall and ceiling transition for uninterrupted conduit connections and wall and ceiling exits. The 90° bend makes it much easier to pull the cables through at a later stage.

- For secure conduit connections on prefabricated concrete elements
- For fitting to formwork edging
- For rigid and flexible DIN EN conduits
- Upper conduit entry above the filigree ceiling, for laying conduits on the building site



Processing instructions



The 90° bend ensures clean transitions and easy cable routing. Just glue the wall and ceiling transition to the formwork edging.



The clip nose is used for securing corrugated conduits with Ø 20 or Ø 25 mm.



Two integrated closing covers protect against dirt and concrete penetration.



Wall-ceiling transition 90° using the oval funnel.

Wall and ceiling transition 90°

- for easier drawing of cable through 90° bends
- for fitting to formwork edging
- accepts rigid and flexible DIN EN conduits
- with closing cover to protect against foreign bodies



DIN EN conduit Ø	20 mm	25 mm
Art.-No.	1261-16	1261-14
Inner packaging/shipping	- / 100	- / 100

Oval funnel

The oval funnel simplifies the exact joining of prefabricated concrete elements with integrated installation conduits. It guarantees safe conduit entry and provides a tolerance compensation of 1 cm or 2 cm during installation.

- Tolerance compensation when joining the concrete elements
- For industrially prefabricated ceiling and wall elements as well as on-site mixed concrete
- For secure connection of installation conduits on transitions of prefabricated concrete elements
- Precise joining of electrical installation conduits
- Tolerance compensation: 2 cm in longitudinal direction and 1 cm in transverse direction.



Tolerance compensation when joining the concrete elements

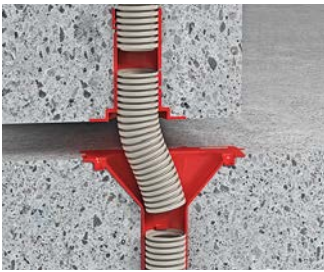

Compensation in longitudinal direction ± 20 mm.

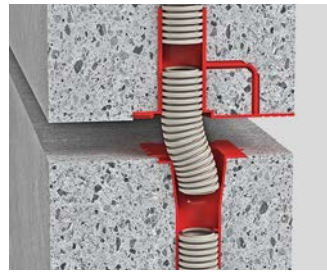

Compensation in transverse direction ± 10 mm.



Wall-ceiling transition 90° using the oval funnel.

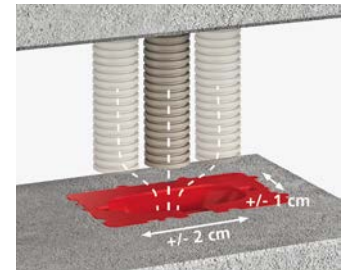

Good compensation of construction tolerances.

Oval funnel

- for the simple connection of DIN EN conduits with tolerance compensation for wall-wall and wall-ceiling transitions
- for installation on the transition edge
- accepts rigid and flexible DIN EN conduits
- with closing cover to prevent ingress of material

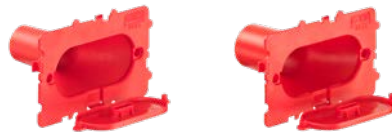

DIN EN conduit Ø	20 mm	25 mm
Art.-No.	1261-42	1261-43
Inner packaging/shipping	- / 100	- / 100



NEW

System Flat 45

The new Flat 45 system makes electrical installation in modularised, industrially produced room systems simpler, more flexible and more economical. With its low installation depth of 45 mm, the Flat 45 one-gang, one-gang junction and wall light connection box is specially adapted for the factory production of complete modules with low wall thicknesses. For secure fixing to the formwork using expansion dowels, rivets and threaded screws, they have fixing options at the front and rear. Exact positioning on the reinforcement with support element on the rear abutment between the two formwork sides is made possible by special fixing and support elements with lateral connectors and support elements for wall thicknesses of 8 and 12 cm.

- Complete range consisting of one-gang box, one-gang junction box and wall light connection box
- System installation depth 45 mm
- Robust and concrete-tight article design
- One-gang junction box with generous lateral terminal compartment
- Can be stably combined over the complete box body with a standardised combination distance of 71 mm
- Easy installation of pre-wired installation accessories in multiple combinations using a bridge that can be broken off afterwards

INNOVATION

Application examples



By using the universal VDE cover (art. no. 1184-90), the Flat 45 system boxes can be used as junction boxes.



The central cable routing option of the universal waterproof cover (Art. No. 1174-99) allows surface-mounted luminaires to be connected safely.



Thanks to the conduit transition coupling $\varnothing 32$ mm (Art. No. 1263-32), the one-gang junction box Flat 45 can be used as a wallbox junction box in walls from 75-80 mm.



The wall light connection box Flat 45 provides space in walls from 50 mm for 3 connection terminals and corresponding cables or for the connection of a game light.



The Flat 45 fixing and support elements for wall thicknesses of 6 to 12 cm press the box front against the working formwork and ensure secure positioning.



The slots on the back of the Flat 45 system boxes are used in 50 mm walls to support the back of the box against the formwork and prevent the box from tilting when fixed on the back.



The signal bristle on the front parts of the Flat 45 system boxes clings to the formwork when it moves and keeps its position visible in the wall surface.

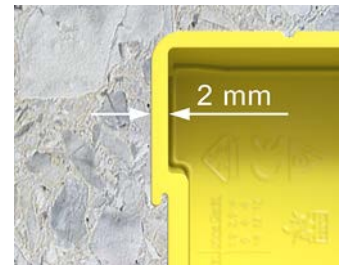

The robust design of the Flat 45 system boxes with a wall thickness of 2 mm keeps them safely in shape even under the highest loads.

One-gang box Flat 45

- For use in walls from 5 cm
- Attachment of the Flat 45 fixing and support elements by push-button connection
- 1-piece with moulded rear part
- Standardised combination distance 71 mm
- with 4 screw domes

NEW

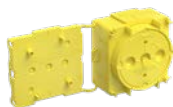

INNOVATION



Product-Data

Length x Width x Depth	81 x 73,4 x 45 mm
Exit opening Ø	60 mm
Markings for wires and cables up to Ø 25 mm	6
Number of parts	1
	Yes
Art.-No.	1256-01
Inner packaging/shipping	- / 100

One-gang junction box Flat 45

- For use in walls from 5 cm
- With lateral terminal compartment
- Attachment of the Flat 45 fixing and support elements by push-button connection
- 1-piece with moulded rear part
- Standardised combination distance 71 mm
- with 4 screw domes

NEW



INNOVATION



Product-Data

Length x Width x Depth	106 x 73,4 x 45 mm
Exit opening Ø	60 mm
Markings for wires and cables up to Ø 25 mm	6
Number of parts	1
	Yes
Art.-No.	1266-01
Inner packaging/shipping	- / 100

Wall light connection box Flat 45

- For use in walls from 5 cm
- Attachment of the Flat 45 fixing and support elements by push-button connection
- 1-piece with moulded rear part

NEW



INNOVATION



Product-Data

Length x Width x Depth	81 x 73,4 x 45 mm
Exit opening Ø	35 mm
Markings for wires and cables up to Ø 25 mm	6
Number of parts	1
	Yes
Art.-No.	1246-01
Inner packaging/shipping	- / 100

Fixing and support element Flat

NEW

INNOVATION



Product-Data

- For wall thicknesses 8 cm and 12 cm
- Lateral outriggers for positioning and fixing to the reinforcement
- Rear support for bracing between the formworks
- Exact shortening to other wall thicknesses due to integrated dimension indication
- Attachment of the Flat 45 fixing and support elements by push-button connection
- Can be used for the following articles:
- One-gang box Flat 45 | Art. No. 1256-01
- One-gang junction box Flat 45 | Art. No. 1266-01
- Wall light connection box Flat 45 | Art. No. 1246-01



Length x Width x Depth	121,7 x 60 x 53 mm	121,7 x 60 x 93,3 mm
Number of parts	1	1
For wall thickness	8 cm	12 cm
Art.-No.	1256-08	1256-12
Inner packaging/shipping	- / 150	- / 100

Expanding dowel

- for quick fixing to steel formwork
- 1-piece in plastic
- for boxes, casings, bushes etc.
- drill hole size required Ø 5.5 mm



Diameter	5,5 mm
Art.-No.	1217-02
Inner packaging/shipping	500 / 2500

Magnet

- for clamp attachment in the box
- for anti-shock fixing of one-gang junction boxes in horizontal formwork
- Adhesive force of 900 N (90 kg)
- Magnet remains on the formwork table after formwork removal
- Centering device for correct positioning during automated production



Art.-No.	1261-81
Inner packaging/shipping	- / 5

International products

For international projects, we offer a large range of products that meet the relevant national standards and regulations.

- Dimensions and approvals based on national standards
- Suitable installation tools
- Many combination options



MD-CD80R centre ceiling box

- For in-factory installation
- Slot for system magnet (Art.-No. 1299-69) and system magnet PLUS (Art.-No. 1299-70)



Depth	85 mm
Exit opening Ø	80 mm
Combination conduit entry for conduits Ø 16 mm / Ø 19 mm	8
Height of the conduit entries	60 mm
Number of parts	2
Art.-No.	AT1032
Inner packaging/shipping	- / 54

MD-CD100R centre ceiling box

- For in-factory installation
- Slot for system magnet (Art.-No. 1299-69) and system magnet PLUS (Art.-No. 1299-70)



Depth	105 mm
Exit opening Ø	80 mm
Combination conduit entry for conduits Ø 16 mm / Ø 19 mm	8
Height of the conduit entries	80 mm
Number of parts	2
Art.-No.	AT1036
Inner packaging/shipping	- / 36



Installation housing for concrete construction

- Free space for luminaires and loudspeakers in concrete ceilings and walls
- Modular and flexible for all installation diameters and installation depths
- For on-site mixed concrete and precast concrete
- Optional for facing concrete
- Toolless combination entry for M20/M25 conduits - can be reclosed
- Maximum contact surface to the concrete ensures optimal thermal management
- Shape-retaining, loadable – and easily fitted
- All housings available with or without tunnel
- Housings and front parts are firmly and stably latched together and can still be aligned as required afterwards
- Signal cover of Ø 68 mm, Ø 75 mm and Ø 80 mm to protect the installation openings from plaster materials.







Installation housings for walls and ceilings





- Free space for luminaires and loudspeakers
- Prevents latent fire hazard
- Ensures long term retention of air tightness as per DIN 18015- 5 or DIN 4102- 7
- Systems for new construction and renovation





Fire-protection housings

- Safe, certified fire-protection housings for built-in luminaires and loudspeakers in fire protection ceilings.
- Integrated fire-retardant coating maintains the fire resistance class F30 (EI30) of the ceiling in fire protection ceilings.
- They prevent fire and flue gases from spreading, thus securing escape routes in buildings
- Suitable for fire resistance from above and from below

Concrete construction				
	HaloX® 100  pg. 246	HaloX® 100 multiconduit entry  pg. 246	HaloX® 180  pg. 246	HaloX® 250  pg. 246
Installation dimensions luminaires/loudspeakers				
max. installation diameter luminaires/loudspeakers	100 mm	100 mm	180 mm	250 mm
max. installation depth (ID) luminaire/loudspeaker	110 mm	110 mm	110 mm	110 mm
Use in facing concrete	•	•	•	•
For universal installation dimensions	•	•	•	•
Conduit entry up to M40	-	•	-	-
Installation variant				
Ceiling installation	•	•	•	•
Wall installation	•	•	•	•
Concreting method				
On-site mixed concrete	pg. 248	pg. 248	pg. 248	pg. 248
Prefabrication	-	-	pg. 261	pg. 261

Walls and ceilings					
	ThermoX® LED for rigid and swivelling built-in LED luminaires  pg. 266	ThermoX® for halogen spotlights and LED luminaires  pg. 270	Spacer for luminaires, loudspeakers, presence detectors, etc.  pg. 273	EnoX® for halogen spotlights, LED luminaires and displays  pg. 268	ThermoX® Iso + installation housing for LED luminaires up to 8 Watt  pg. 68
Product details					
Installation below air-tight level	•	•	•	•	-
Installation inside air-tight level	•	•	-	•	-
Installation in the insulated level	-	-	-	-	•
Housing height	70/95 mm	90 mm	40 - 100 mm	60 mm	100 - 160 mm
Luminaire/loudspeaker installation diameters	70/81 mm	max. 86 mm	68 - 80 mm	max. 120 mm	max. 86 mm
max. installation depth (ID) luminaire/loudspeaker	60/85 mm	65/70 mm	95 mm	57 mm	70 - 130 mm
Installation variants					
retrofitting	•	•	•	-	-
Wall installation	-	-	-	•	-
Deckeneinbau	•	•	•	•	•

Fire protection		
	FlamoX® – for luminaires and loudspeakers  pg. 303	
	 pg. 303	
Installation dimensions for luminaires and loudspeakers		
max. installation diameter luminaires/loudspeakers	100 mm	180 mm
For universal installation dimensions	•	•
max. installation depth (ID) luminaire/loudspeaker	100 mm	150 mm
Installation variants		
retrofitting	•	•
in independent sub-ceilings EI30 / F30	•	•
Installation without additional suspension	•	•
Mounting without additional fire protection materials or sealing compounds	•	•



HaloX®

Free space for planning, installation
and ambience.

One system for all eventualities



HaloX® for on-site mixed concrete

The modular housing system for ceilings and walls is available in 3 different housing sizes with fixed or variable installation diameters of up to 250 mm, also available for facing concrete requirements.

pg. 247



HaloX® for precast concrete

The housing system for ceilings and walls is available in 2 different housing sizes with fixed or variable installation diameters up to 250 mm (up to 210 mm with tolerance compensation).

pg. 260



HaloX® for retrofitting

HaloX® for the retrofitting of installation housings in slab ceilings and solid ceilings. After creating a drilling hole, the housings can be extended according to the ceiling thickness.

pg. 257

A system for all eventualities – for processing on-site mixed concrete, the front parts can be fixed to the working formwork with nails. Prefix® installation sets are available for fixing to the opposing formwork. In precast concrete, the housings can be installed with adhesive or magnetic attachment.



Combination entry for conduits M20/M25 – toolless opening technology with safe conduit retention and depth stop, without the need to shorten the conduits on the inside. Reusable in case of installation changes or incorrect assignments.



Pressure-resistant tunnel to accommodate operating devices. Minimal impact on the main structure – does not require reinforcement steel to be cut to create the tunnel.

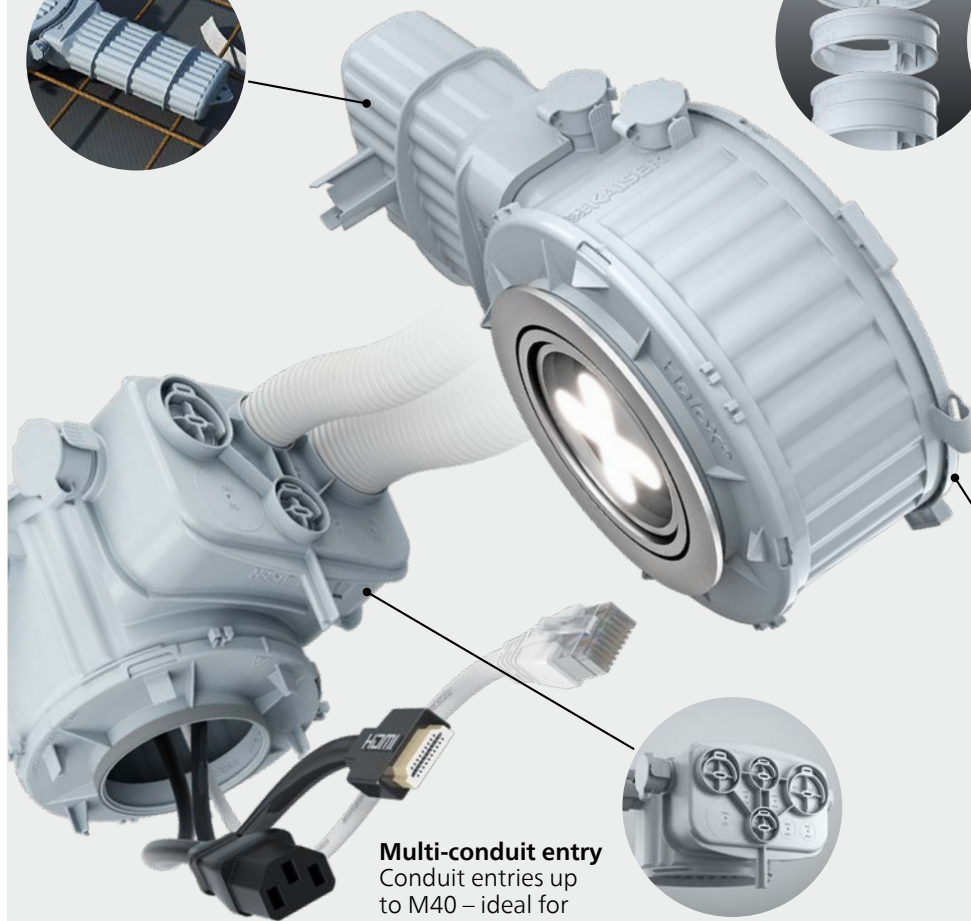

Multi-conduit entry
Conduit entries up to M40 – ideal for pre-assembled cables.

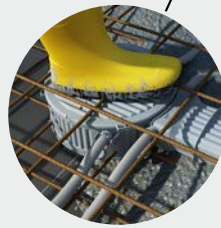

Shape-retaining and resilient. Compact housing with stabilizing wave profile provides the necessary stability during the concreting process – even under extreme loads.

Continuous housing system – modular, flexible for luminaires and loudspeakers at all heights and with mounting diameters up to 250 mm, also for facing concrete requirements.



For walls and ceilings

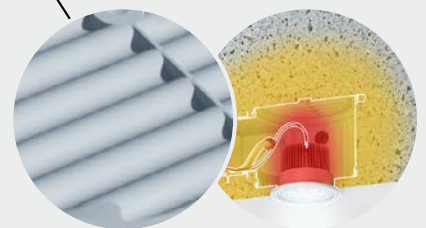

Wave-shaped surface profile ensures maximum housing surface for optimum heat dissipation via the concrete.

FLUSH-MOUNTING

CAVITY WALL

CONCRETE

HOUSINGS

FIRE PROTECTION

PLUGGABLE

CONNECTIVITY

CABLE GLANDS

TOOLS

SERVICE



HaloX® concrete installation housing

The new HaloX® housing system offers space for new light or sound in concrete ceilings and walls. Shape-retaining, loadable and in a modular design, the HaloX® system provides a secure installation compartment for loudspeakers and luminaires with LED, halogen or compact fluorescent lamps. Round, square or universal front parts ensure that any device up to a ceiling cut-out of 250 mm can be installed, even when facing concrete is required. Optional extension rings provide more space for greater installation depths. The toolless combination entry for M20/M25 conduits is easy to internal and, even with incorrect occupancy, is easily closed again. It provides secure conduit retention with depth stop, so there is no need for later internal shortening of the conduits.

- For on-site mixed concrete and precast concrete - for wall and ceiling
- For luminaires and loudspeakers with installation diameters up to 250 mm
- All housings available with and without a tunnel
- Toolless entry technology for M20/M25 conduits
- Optimal heat management thanks to maximum surface contact with the concrete
- Minimal effect on the statics - no cuts to the reinforcement required in the tunnel area



Temperature management for HV LED and LV LED luminaires



230V built-in LED luminaire with 68 mm installation diameter

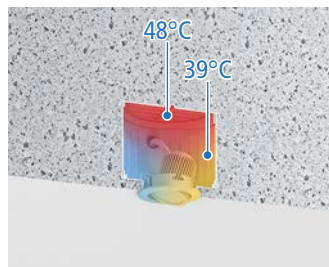

Temperature profile 230V built-in LED luminaire max. 20 W



LV LED luminaire installation diameter 140 mm

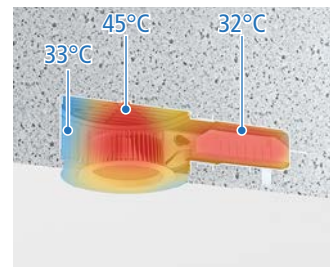

Temperature profile LV LED luminaire max. 35 W

Temperature management for HV halogen and TC luminaires



230V built-in luminaire with 100 mm installation diameter

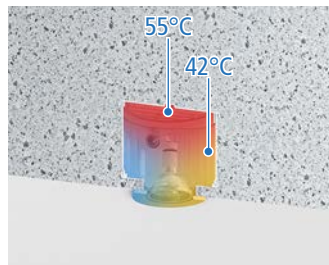

Temperature profile HV halogen luminaire max. 75 W (230V)



Installation downlight TC-TEL 2 x 26 W with installation diameter of 215 mm

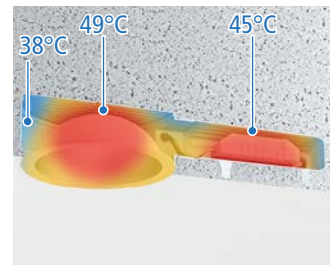

Temperature profile installation downlight TC-TEL with 2 x 26 W

System overview of HaloX® for on-site mixed concrete

1 Installation space for luminaires / loudspeakers and operating devices



without additional space for operating devices



HaloX® 100
1281-00
p. 249



HaloX® 180
1282-00
p. 249



HaloX® 250
1283-00
p. 249



Additional space for operating devices

up to 150 x 90 x 50 mm*



HaloX® 100 with tunnel 190
1281-30
p. 249



HaloX® 180 with tunnel 190
1282-30
p. 249



Zusatzraum für größere Betriebsgeräte

up to 280 x 90 x 50 mm*



HaloX® 180 with tunnel 325
1282-40
p. 249

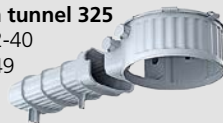

HaloX® 250 with tunnel 325
1283-40
p. 249



For prefabricated cables

Conduits up to M40

HaloX® 100 multi-conduit entry
1281-15
p. 250



* max. dimension of operating devices must be checked depending on the installation opening

2 Installation diameter for luminaires/loudspeakers

round

- Front parts round
- Front parts round (**Facing concrete**)

Ø 68 - 100 mm
p. 250

Ø 100 - 180 mm
p. 252

Ø 180 - 250 mm
p. 253

square

- Front parts square
- Front parts square (**Facing concrete**)

68x68 - 75x75 mm
p. 251

-

-

universal

- Universal front part plastic (a)
- or mineral fibreboard (b)

Ø max. 100 mm
p. 251

Ø max. 180 mm
p. 252

Ø max. 250 mm
p. 253

specific

Individual Styrofoam moulded parts (optional for **Facing concrete**)

p. 256

p. 256

p. 256

3 Installation depth



Installation height > 110 mm



Extension rings 10/25/50 mm

1281-21/25/50 | p. 254/258/259



Extension rings 25/50 mm

1282-25/50 | p. 254/265



Extension rings 25/50 mm

1283-25/50 | p. 254/265

4 Accessories



Wall installation in vertical formwork



Prefix® installation set for fixing to the reinforcement
1299-65 | p. 254

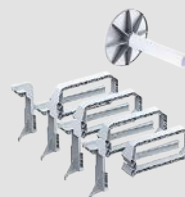

Wall installation set for fitting in vertical formwork
1299-60...64 | p. 254

Prefix® installation set for fixing to the reinforcement
1299-66 | p. 254

Easy finding after plastering



Signal cover

1281-31...33 | p. 255/264



HaloX® concrete installation housing (on-site mixed concrete)

The shape-retaining HaloX® system has a modular design for fitting in on-site mixed concrete. Three housing diameters with a large number of round, square and universal front parts allow the integration of luminaires and loudspeakers up to an installation diameter of 250 mm, including in facing concrete. With a tunnel, the system provides sufficient space for operating devices, such as LED drivers. Optional extension rings to increase the installation depth. All front parts are moisture-repellent and can be positioned exactly and nailed-on even before the first reinforcement is laid. Housings and front parts are firmly and stably latched together and can still be aligned as required afterwards. By means of the toolless, opening technology with a M20/M25 combination entry, conduits can be inserted quickly and easily and, even if the population is incorrect, the entry can easily be closed again. It provides secure conduit retention with a depth stop, so there is no need for subsequent internal shortening of the conduits. After casting, front parts with a defined installation diameter can be opened with a targeted blow of the hammer. The front parts for universal opening sizes can be plastered locally or plastered over. You can then cut the required installation opening using standard cutting tools e.g. PROFi cutter.

- For walls and ceilings
- Housings and front parts are latched together securely and sturdily, and can also be subsequently aligned as required
- All housing sizes are available with and without a tunnel
- Toolless entry technology for M20/M25 conduits
- Optimal heat management thanks to maximum surface contact with the concrete
- Minimal impact on the main structure – does not require reinforcement steel to be cut to create the tunnel



Examples of use



The combination conduit entry can be opened simply by hand. If necessary, conduit entries that have already been opened can simply be closed again.



The flat front part (20 mm) lies below the lower reinforcement layer, thus not hindering any subsequent works, and can be precisely aligned using the centre marking.



The combination conduit entry provides a secure connection for both jacketed and non-jacketed pipes and can be used individually for conduit sizes of 20 mm or 25 mm diameter. It offers a high degree of pull-out safety and, thanks to the integrated depth stop, makes subsequent internal shortening of the conduits superfluous.



All HaloX® installation housings are robustly designed and meet the requirements of the harsh conditions at the construction site and in the concrete plant.

HaloX® 100 / 180 / 250 (on-site mixed concrete)

- Toolless combination entry for M20/M25 conduits
- Conduit entry limitation to prevent the need to shorten the conduit inside



3D animation



Product-Data



System	HaloX® 100	HaloX® 180	HaloX® 250
Ceiling exit (CE) Ø	0-100 mm	0-180 mm	0-250 mm
Max. installation depth luminaire / loudspeaker	110 mm	110 mm	110 mm
LED wattage max.	20 Watt	35 Watt	45 Watt
Lamp wattage max.	50 Watt	75 Watt	100 Watt
Housing diameter Ø	130 mm	210 mm	280 mm
Depth incl. front part	120 mm	120 mm	120 mm
Combination entry for M20/M25 conduits	2	2	2
Art.-No.	1281-00	1282-00	1283-00
Inner packaging/shipping	- / 10	- / 10	- / 10

HaloX® 100 / 180 / 250 with transformer tunnel (on-site mixed concrete)

- Toolless combination entry for M20/M25 conduits
- Conduit entry limitation to prevent the need to shorten the conduit inside
- No reinforcement cuts in tunnel section area



3D animation



Product-Data



System	HaloX® 100	HaloX® 180	HaloX® 180	HaloX® 250
Ceiling exit (CE) Ø	0-100 mm	0-180 mm	0-180 mm	0-250 mm
Max. installation depth luminaire / loudspeaker	110 mm	110 mm	110 mm	110 mm
LED wattage max.	20 Watt	35 Watt	35 Watt	45 Watt
Lamp wattage max.	50 Watt	75 Watt	75 Watt	100 Watt
Housing diameter Ø	130 mm	210 mm	210 mm	280 mm
Depth incl. front part	120 mm	120 mm	120 mm	120 mm
Tunnel length	190 mm	190 mm	325 mm	325 mm
Tunnel width	140 mm	140 mm	140 mm	140 mm
Tunnel height	85 mm	85 mm	85 mm	85 mm
Combination entry for M20/M25 conduits	4	4	4	4
Art.-No.	1281-30	1282-30	1282-40	1283-40
Inner packaging/shipping	- / 10	- / 10	- / 10	- / 10

HaloX® system for on-site mixed concrete

for luminaires and loudspeakers

INNOVATION



3D animation

HaloX® 100 Multi-conduit entry

- 4 M20/M25 combination entries with toolless opening technology
- Multi-conduit entry up to M40 with secure conduit retention
- Minimal effect on statics - no cuts to the reinforcement
- Shape-retaining, loadable and easily fitted
- Suitable with all HaloX 100 front parts



Ceiling exit (CE) Ø	0-100 mm
Max. installation depth luminaire / loudspeaker	110 mm
LED wattage max.	20 Watt
Lamp wattage max.	50 Watt
Housing diameter Ø	130 mm
Depth incl. front part	120 mm
Combination entry for M20/M25 conduits	6
Combination entry for M25/M32 conduits	1
Combination entry for M32/M40 conduits	1
Cable entries up to Ø 16 mm	4
Cable entries up to Ø 32 mm	1
Art.-No.	1281-15
Inner packaging/shipping	- / 10

HaloX® 100 front parts

- Suitable for housing with Art. No. 1281-XX and 1290-30
- Suitable with signal cover



Ceiling exit (CE) Ø	Min. luminaire covering Ø	Art.-No.	Inner packaging/ shipping
68 mm	75 mm	1281-01	- / 10
75 mm	82 mm	1281-02	- / 10
80 mm	87 mm	1281-03	- / 10
85 mm	92 mm	1281-04	- / 10
90 mm	97 mm	1281-05	- / 10
95 mm	102 mm	1281-06	- / 10
100 mm	107 mm	1281-07	- / 10

HaloX® 100 front parts for facing concrete

- in facing concrete version
- elastomer seal with flexible sealing edge
- prevents ingress of concrete, discolouring and sand blast dust
- for exact flush finishes in facing concrete without additional reworking
- Suitable for housing with Art. No. 1281-XX and 1290-30



Ceiling exit (CE) Ø	Min. luminaire covering Ø	Art.-No.	Inner packaging/ shipping
68 mm	80 mm	1281-61	- / 8
75 mm	87 mm	1281-62	- / 8
80 mm	92 mm	1281-63	- / 8
85 mm	97 mm	1281-64	- / 8
90 mm	102 mm	1281-65	- / 8
95 mm	107 mm	1281-66	- / 8
100 mm	112 mm	1281-67	- / 8

HaloX® 100 front parts, square

- Suitable for housing with Art. No. 1281-XX and 1290-30



Ceiling exit (CE) Ø	68 x 68 mm	75 x 75 mm
Min. luminaire covering	75 x 75 mm	82 x 82 mm
Art.-No.	1281-08	1281-09
Inner packaging/shipping	- / 10	- / 10

HaloX® 100 front parts, square for facing concrete

- in facing concrete version
- elastomer seal with flexible sealing edge
- prevents ingress of concrete, discolouring and sand blast dust
- Suitable for housing with Art. No. 1281-XX and 1290-30



Ceiling exit (CE) Ø	68 x 68 mm	75 x 75 mm
Min. luminaire covering	80 x 80 mm	87 x 87 mm
Art.-No.	1281-68	1281-69
Inner packaging/shipping	- / 8	- / 8

HaloX® 100 universal front parts

- Suitable for housing with Art. No. 1281-XX and 1290-30
- Suitable with signal cover



Ceiling exit (CE) Ø	0-100 mm	0-100 mm
Universal plastic panel	Yes	-
Universal mineral fibreboard	-	Yes
Art.-No.	1281-10	1281-11
Inner packaging/shipping	- / 10	- / 8

FLUSH-MOUNTING

CAVITY WALL

CONCRETE

HOUSINGS

FIRE PROTECTION

PLUGGABLE

CONNECTIVITY

CABLE GLANDS

TOOLS

SERVICE

HaloX® system for on-site mixed concrete

for luminaires and loudspeakers

HaloX® 180 front parts

· Suitable for housing with Art. No. 1282-XX



Ceiling exit (CE) Ø	Min. luminaire covering Ø	Art.-No.	Inner packaging/ shipping
100 mm	107 mm	1282-01	- / 10
110 mm	117 mm	1282-02	- / 10
125 mm	132 mm	1282-03	- / 10
145 mm	152 mm	1282-04	- / 10
160 mm	167 mm	1282-05	- / 10
180 mm	187 mm	1282-06	- / 10

HaloX® 180 front parts for facing concrete

· Suitable for housing with Art. No. 1282-XX



Ceiling exit (CE) Ø	Min. luminaire covering Ø	Art.-No.	Inner packaging/ shipping
100 mm	112 mm	1282-61	- / 10
110 mm	122 mm	1282-62	- / 10
125 mm	137 mm	1282-63	- / 10
145 mm	157 mm	1282-64	- / 10
160 mm	172 mm	1282-65	- / 10
180 mm	192 mm	1282-66	- / 10

HaloX® 180 universal front parts

- Suitable for housing with Art. No. 1282-XX
- Suitable with signal cover



Ceiling exit (CE) Ø	0-180 mm	0-180 mm
Universal plastic panel	Yes	-
Universal mineral fibreboard	-	Yes
Art.-No.	1282-10	1282-11
Inner packaging/shipping	- / 10	- / 10

HaloX® 250 front parts

· Suitable for housings with Art. No. 1283-XX



Ceiling exit (CE) Ø	Min. luminaire covering Ø	Art.-No.	Inner packaging/ shipping
180 mm	187 mm	1283-01	- / 10
190 mm	197 mm	1283-02	- / 10
200 mm	207 mm	1283-03	- / 10
215 mm	222 mm	1283-04	- / 10
240 mm	247 mm	1283-05	- / 10
250 mm	257 mm	1283-06	- / 10

HaloX® 250 front parts for facing concrete

· Suitable for housings with Art. No. 1283-XX



Ceiling exit (CE) Ø	Min. luminaire covering Ø	Art.-No.	Inner packaging/ shipping
180 mm	192 mm	1283-61	- / 10
190 mm	202 mm	1283-62	- / 10
200 mm	212 mm	1283-63	- / 10
215 mm	227 mm	1283-64	- / 10
240 mm	252 mm	1283-65	- / 10
250 mm	262 mm	1283-66	- / 10

HaloX® 250 universal front parts

· Suitable for housings with Art. No. 1283-XX
· Suitable with signal cover



Ceiling exit (CE) Ø	0-250 mm	0-250 mm
Universal plastic panel	Yes	-
Universal mineral fibreboard	-	Yes
Art.-No.	1283-10	1283-11
Inner packaging/shipping	- / 10	- / 10

Replacement mineral fibreboard for HaloX Ø 100, 180 and HaloX Ø 250

· for front parts with Art. Nos. 1281-11, 1282-11 and 1283-11



System	HaloX® 100	HaloX® 180	HaloX® 250
Art.-No.	1281-27	1282-27	1283-27
Inner packaging/shipping	- / 10	- / 10	- / 10

HaloX® system for on-site mixed concrete for luminaires and loudspeakers

Extension rings HaloX®

- To increase installation depth



Height	System	Max. installation depth luminaire / loudspeaker	For Art. No.	Art.-No.	Inner packaging/ shipping
10 mm	HaloX® 100	+ 10 mm	1281-xx/1290-30	1281-21	- / 10
25 mm	HaloX® 100	+ 25 mm	1281-xx/1290-30	1281-25	- / 10
50 mm	HaloX® 100	+ 50 mm	1281-xx/1290-30	1281-50	- / 10
25 mm	HaloX® 180	+ 25 mm	1282-xx	1282-25	- / 10
50 mm	HaloX® 180	+ 50 mm	1282-xx	1282-50	- / 10
25 mm	HaloX® 250	+ 25 mm	1283-xx	1283-25	- / 10
50 mm	HaloX® 250	+ 50 mm	1283-xx	1283-50	- / 10

Installation set for wall installation

- Installation kit for wall installation in vertical formwork
- 2-piece, consists of support element and seating bearing
- For HaloX Ø 210 (1282-XX) and HaloX Ø 280 (1283-XX)



For luminaire or loudspeaker installation height	Art.-No.	Inner packaging/ shipping
100 mm	1299-60	- / 1
125 mm	1299-61	- / 1
150 mm	1299-62	- / 1
175 mm	1299-63	- / 1
200 mm	1299-64	- / 1

Prefix® installation set

- Installation set for wall installation
- for fixing to the opposing formwork



for HaloX® 100	Yes	-
for HaloX® 180/250	-	Yes
Art.-No.	1299-65	1299-66
Inner packaging/shipping	- / 1	- / 1

Signal cover

The new signal cover ensures a clean ceiling appearance and avoids time-consuming reworking of the installation opening after plastering. As an accessory item for the KAISER HaloX® concrete installation housings, the signal cover is simply inserted into the already opened front part after formwork removal from the rough ceiling or wall. Thus, the installation opening is securely closed and protected against penetration of plaster. Three signal bristles, in combination with the bright red colour, ensure that the installation opening in the plastered rough ceiling or wall can be found quickly and easily. The installation opening can be opened with one targeted blow of the hammer without destroying the surrounding plaster pattern. With one turn of the knife edge, cleaning residues are removed effortlessly. The flexible signal cover can then be removed easily and cleanly. Its specially serrated edge structure preserves the plaster edge.

- Stable and robust clamping in installation diameters of Ø 68 mm, Ø 75 mm and Ø 80 mm
- For use in fixed HaloX® front parts, universal HaloX® front parts and other installation openings
- Stable signal bristles and strong colouring for easy retrieval from the plaster surface
- Reusable, easy to clean



NEW

Application examples



After formwork removal and pull-in of the supply conduits, the signal cover is inserted into the installation opening.



The red signal bristles are flexible during the smoothing process and do not hinder this work step but, at the same time, are stable enough to keep the position in the plaster surface recognisable.

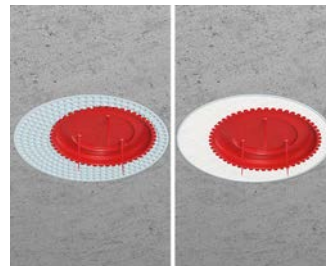

In addition to being able to use the HaloX® front parts with fixed exit opening, these can also be inserted into the universal HaloX® front parts.



In the case of factory-fitted HaloX® housings for one of the system magnets (e. g. 1299-69), the signal covers allow the recess to be smoothed or filled over the entire surface.

Signal cover

- Protects the interior of the housing
- Three stable signal bristles and strong colouring for easy retrieval from the plastered rough ceiling.
- Serrated edge structure for a clean installation opening

NEW



For installation opening	68 mm	75 mm	80 mm
Art.-No.	1281-31	1281-32	1281-33
Inner packaging/shipping	10 / 100	10 / 100	10 / 100



Styrofoam moulded parts

HaloX® housing with Styrofoam moulded part for customised solutions. The mouldings are available in any shape (round, square, rectangular or triangular) and in various thicknesses or to suit your specific needs. They can be supplied ready-mounted to the housing or provided separately. A facing concrete version is also available. The Styrofoam moulded parts for facing concrete have an additional elastomer sheath, and its elasticity prevents the dry concrete from cracking.

- For individual installation openings
- Any shape possible (for round, square, rectangular and other installation openings)
- For in-situ or prefabricated concrete
- Prevents discolouring and sand blast dust in facing concrete version
- For exact flush finishes in facing concrete without reworking

Planning instruction

Almost every conceivable shape can be realised using the Styrofoam moulded parts. The maximum dimensions of the front parts (diameter/diagonals) result from the maximum dimensions of the respective housing front rings. Please note that the clamping range of luminaires and loudspeakers must be at least the thickness of the Styrofoam moulded parts plus 8 mm. In the case of Styrofoam moulded parts with a thickness of > 20 mm, take into account the support provided.

Styrofoam moulded parts

- For individual installation openings (round, square)
- With maximum diameter up to 300 mm and max. height up to 50 mm
- For all housings with Art. No. 12XX-XX



Art.-No.	1292-90
Inner packaging/shipping	- / 1

System overview of HaloX® for retrofitting



Installation diameter for luminaire/
loudspeaker max. 100 mm

1 Installation space for luminaires / loudspeakers and operating devices

without additional space for operating devices



Slab ceiling

Solid ceiling



HaloX® 100
installation set
1281-20 | p. 258



HaloX® 100
1281-00 | p. 249



HaloX® housing for core drillings
in solid ceilings
1290-30 | p. 259

Additional space for operating devices

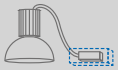

up to 150 x 90 x 50 mm*



HaloX® 100
installation set
1281-20 | p. 258



HaloX® 100
with tunnel 190
1281-30 | p. 249

For prefabricated cables

Conduits up to M40



HaloX® 100
installation set
1281-20 | p. 258



HaloX® 100
multi-conduit
entry
1281-15 | p. 250

2 Thickness of the slab ceiling

Thickness of the slab ceiling > 50 mm



Extension rings
10/25/50 mm
1281-21/25/50
p. 254/258/259

* max. dimension of operating
devices must be checked
depending on the installation
opening

3 Installation diameters for luminaires/loudspeakers



round
Front parts round



Ø 68 - 100 mm
p. 250



square
Front parts square



68x68 - 75x75 mm
p. 251



Facing concrete: round
Front parts round with elastomer
seal for facing concrete



Ø 68 - 100 mm
p. 250

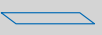

Facing concrete: square
Front parts square with elastomer
seal for facing concrete



68x68 - 75x75 mm
p. 251



universal
Universal front part plastic (a)
or mineral fibreboard (b)



Ø max. 100 mm
p. 251



specific
Individual Styrofoam moulded parts
(optional for **facing concrete**)



p. 256

4 Installation depth

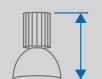

Installation height > 110 mm



Extension rings
10/25/50 mm
1281-21/25/50 | p. 254/258/259

HaloX® system for retrofitting in concrete ceilings

for luminaires and loudspeakers

HaloX® 100 installation kit



HaloX® 100 installation kit can be retrofitted in existing slab ceilings (50 mm thickness and greater) with or without transformer tunnel.

- For retrofitting in slab ceilings
- Minimal effect on statics
- Large selection of opening sizes up to Ø 100 mm
- Extension rings for bridging the slab ceiling element and for increasing the luminaire installation depth



Note



For slabs thicker than 50 mm, the housing can be expanded in 10/25/50 mm steps using the extension rings.

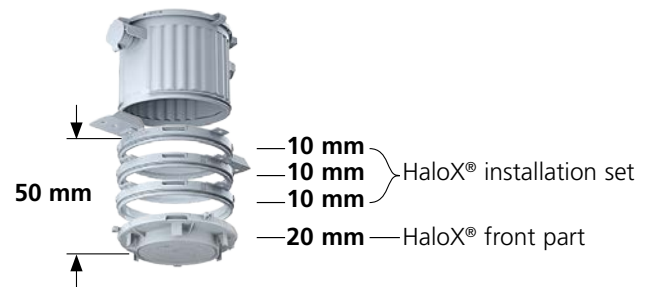

HaloX® installation kit mounting

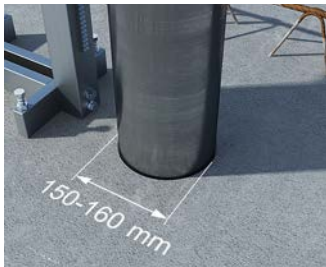

Cut drilling hole (Ø 150–160 mm) in the slab ceiling.



Combine the extension ring and front part to correspond to the ceiling thickness and installation depth.



Attach the housing and place in the drilling hole, mark and fasten. Install the conduit in the KSK entry.

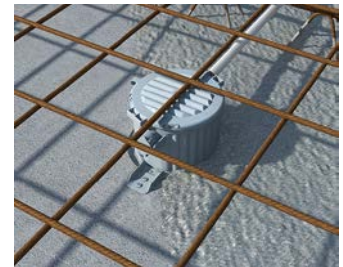

If necessary, secure the fixed housing with wire to the reinforcement.

HaloX® 100 installation kit

- for retrofitting of HaloX®-O housings into slab ceilings
- required hole size Ø 150-160 mm



Height	30 mm	10 mm
System	HaloX® 100	HaloX® 100
For Art. No.	1281-xx	1281-xx/1290-30
Max. installation depth luminaire / loudspeaker	-	+ 10 mm
Art.-No.	1281-20	1281-21
Inner packaging/shipping	- / 10	- / 10

For retrofitting

HaloX® concrete installation housing for solid concrete ceilings can be inserted into existing and retrofitted drilling holes.

- For retrofitting in solid ceilings
- Minimal effect on statics
- Quick installation with snap-in connections
- Robust construction, ideal for use on building sites
- Large selection of opening sizes up to Ø 100 mm



Installation



Use the universal opening cutter to make accurate opening for the appropriate conduit sizes.



Join the housing components to correspond to the ceiling thickness and installation depth.



Now insert the complete housing, including the installation into the opening or drilling hole. Then...



...fill the free space with concrete and compact it. A formwork board fitted underneath prevents the concrete from running out.

HaloX® housing for drilling holes in solid ceilings

- for retrofitting in solid ceilings
- required hole size Ø 150-160 mm
- Take into consideration the ceiling thickness - at least 3 cm concrete cover is needed on top of the box
- suitable for front parts with Art. No. 1281-XX



Ceiling exit (CE) Ø	0-100 mm
Depth incl. front part	133 mm
LED wattage max.	20 Watt
Lamp wattage max.	50 Watt
Diameter	130 mm
Art.-No.	1290-30
Inner packaging/shipping	- / 10

HaloX® extension rings

- for increasing luminaire fitting depth
- to be clipped between the front part and the housing
- Multiple extensions possible



Height	10 mm	25 mm	50 mm
System	HaloX® 100	HaloX® 100	HaloX® 100
Max. installation depth luminaire / loudspeaker	+ 10 mm	+ 25 mm	+ 50 mm
For Art. No.	1281-xx/1290-30	1281-xx/1290-30	1281-xx/1290-30
Art.-No.	1281-21	1281-25	1281-50
Inner packaging/shipping	- / 10	- / 10	- / 10

System overview of HaloX® for precast concrete

1 Installation compartment for luminaires / loudspeakers and operating devices



max. 140 mm
(with tolerance compensation)
max. 180 mm
(without tolerance compensation)



max. 210 mm
(with tolerance compensation)
max. 250 mm
(without tolerance compensation)

Adhesive attachment
one-piece housing with universal mineral fibre-board

Magnet attachment
one-piece housing with universal plastic plate for the magnet recess

Adhesive attachment
one-piece housing with universal mineral fibre-board

Magnet attachment
one-piece housing with universal plastic plate for the magnet recess

System magnet
1299-69 | p. 212/264

System magnet PLUS
1299-70 | p. 213/264

System magnet
1299-69 | p. 212/264

System magnet PLUS
1299-70 | p. 213/264

without additional space for operating devices



HaloX® 180
1282-71 | p. 262



HaloX® 180
1282-74 | p. 263



HaloX® 250
1283-71 | p. 262



HaloX® 250
1283-74 | p. 263

Additional space for operating devices

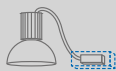

up to max. 150 x 90 x 50 mm*



HaloX® 180 with tunnel 190
1282-72 | p. 262



HaloX® 180 with tunnel 190
1282-75 | p. 263

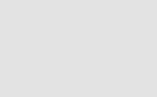

HaloX® 250 with tunnel 190
1283-73 | p. 262

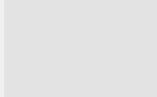

HaloX® 250 with tunnel 190
1283-76 | p. 263

Additional space for larger operating devices

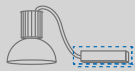

up to max. 280 x 90 x 50 mm*



HaloX® 180 with tunnel 325
1282-73 | p. 262



HaloX® 180 with tunnel 325
1282-76 | p. 263



HaloX® 250 with tunnel 325
1283-73 | p. 262



HaloX® 250 with tunnel 325
1283-76 | p. 263

2 Installation depth



Installation height
> 110 mm



Extension rings 25/50 mm
1282-25/50 | p. 254/265



Extension rings 25/50 mm
1283-25/50 | p. 254/265

3 Accessories



Wall installation in vertical formwork



Wall installation set for fitting in vertical formwork
1299-60...64 | p. 254

Easy to locate after plastering



Signal cover
1281-31...33 | p. 255/264

* max. dimension of operating devices must be checked depending on the installation opening

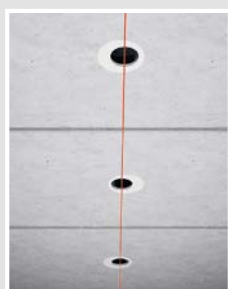

Tolerance compensation

Depending on the installation diameter, at a later date you can correct inaccuracies which occurred during the laying of the slab ceilings. Use the KAISER VARIOCUT hole cutter to make accurate installation openings in the front parts.

HaloX® 180



HaloX® 250

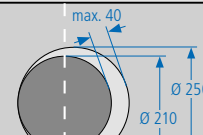
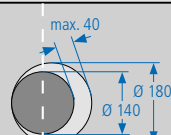
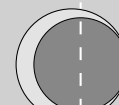

HaloX® concrete installation housing (precast concrete)

System HaloX® is designed as a single piece for fitting in precast concrete. The housings can easily be aligned on the formwork table by means of markings on the housing. The housing with pre-fitted mineral fibreboard allows easy glueing and the housings can be turned by 360° on the formwork table even after glueing. Housings with pre-fitted front parts to hold the system magnet (Art. No. 1299-69/1299-70) are available for magnet attachment. Laying tolerances which may occur during the fitting of panel elements are compensated for via the housing sizes in connection with a variable cut-out area. Because of the compact dimensions of the housings, the reinforcement can easily be placed around the housing. For luminaires or loudspeakers with installation depths equal to or greater than 110 mm, the installation compartment of the HaloX® housings can be increased on the on-site concrete building site by means of extension rings. The fitting of the conduits on-site takes place without the need for tools for M20/M25 conduits without any internal shortening of the conduits.

- For precast concrete slab ceilings and wall elements.
- 3 housing sizes with and without tunnel
- Single-part housings with integrated mineral fibreboard for easy adhesive fixing
- One-part housings with plastic panel for magnet attachment
- Toolless entry technology for M20/M25 conduits
- Compensation for laying tolerances on the concrete building site
- Optimal heat management thanks to maximum surface contact with the concrete



Installation



Mounting of the single-piece housing with mineral fibreboard...



...fitting of the one-part housing by means of system magnet (Art. No. 1299-69/1299-70).



Prefabricated element with integrated HaloX® housings is laid on concrete building site.



Subsequent adjustment of the housing height on the building site.



Toolless combination entry of M20/M25 conduits with conduit stop - no later shortening of the conduits.

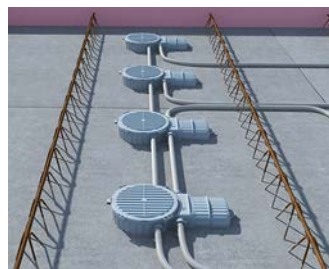

After fitting of the conduits, concreting on the planned ceiling thickness takes place with the on-site mixed concrete process.

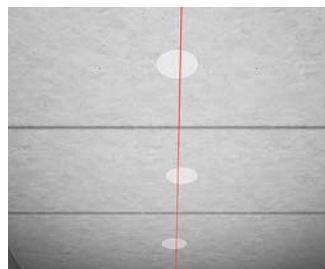

Panel element laying tolerances can be compensated for using the universal front parts (see system overview).

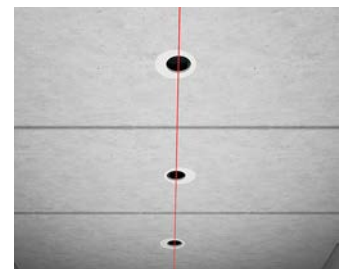

Cut the installation opening e.g. with the PROFI cutter (Art. No. e.g. with 1081-10).



HaloX® system for precast concrete

for luminaires and loudspeakers

HaloX® 180 / 250 for precast concrete for adhesive attachment

- One-part housing with integrated mineral fibreboard
- Toolless combination entry for M20/M25 conduits
- Conduit entry limitation to prevent the need to shorten the conduit inside



3D animation

System	HaloX® 180	HaloX® 250
Ceiling exit (CE) Ø	0-180 mm	0-250 mm
Max. installation depth luminaire / loudspeaker	110 mm	110 mm
LED wattage max.	35 Watt	45 Watt
Lamp wattage max.	75 Watt	100 Watt
Housing diameter Ø	210 mm	280 mm
Depth incl. front part	120 mm	120 mm
Combination entry for M20/M25 conduits	2	2
Art.-No.	1282-71	1283-71
Inner packaging/shipping	- / 10	- / 10

HaloX® 180 / 250 with transformer tunnel (for precast concrete)

- One-part housing with integrated mineral fibreboard
- Toolless combination entry for M20/M25 conduits
- Conduit entry limitation to prevent the need to shorten the conduit inside



3D animation

System	HaloX® 180	HaloX® 180	HaloX® 250
Ceiling exit (CE) Ø	0-180 mm	0-180 mm	0-250 mm
Max. installation depth luminaire / loudspeaker	110 mm	110 mm	110 mm
LED wattage max.	35 Watt	35 Watt	45 Watt
Lamp wattage max.	75 Watt	75 Watt	100 Watt
Housing diameter Ø	210 mm	210 mm	280 mm
Depth incl. front part	120 mm	120 mm	120 mm
Tunnel length	190 mm	325 mm	325 mm
Tunnel width	140 mm	140 mm	140 mm
Tunnel height	85 mm	85 mm	85 mm
Combination entry for M20/M25 conduits	4	4	4
Art.-No.	1282-72	1282-73	1283-73
Inner packaging/shipping	- / 10	- / 10	- / 10

HaloX® 180 / 250 for precast concrete for magnet attachment

- One-part housing for holding the system magnet (Art. No. 1299-69) and system magnet PLUS (Art. No. 1299-70)
- Toolless combination entry for M20/M25 conduits
- Conduit entry limitation to prevent the need to shorten the conduit inside
- Suitable with signal cover



3D animation

System	HaloX® 180	HaloX® 250
Ceiling exit (CE) Ø	0-180 mm	0-250 mm
Max. installation depth luminaire / loudspeaker	110 mm	110 mm
LED wattage max.	35 Watt	45 Watt
Lamp wattage max.	75 Watt	100 Watt
Housing diameter Ø	210 mm	280 mm
Depth incl. front part	120 mm	120 mm
Combination entry for M20/M25 conduits	2	2
Art.-No.	1282-74	1283-74
Inner packaging/shipping	- / 10	- / 10

HaloX® 180 / 250 with tunnel for precast concrete for magnet attachment

- One-part housing for holding the system magnet (Art. No. 1299-69) and system magnet PLUS (Art. No. 1299-70)
- Toolless combination entry for M20/M25 conduits
- Conduit entry limitation to prevent the need to shorten the conduit inside
- Suitable with signal cover



3D animation

System	HaloX® 180	HaloX® 180	HaloX® 250
Ceiling exit (CE) Ø	0-180 mm	0-180 mm	0-250 mm
Max. installation depth luminaire / loudspeaker	110 mm	110 mm	110 mm
LED wattage max.	35 Watt	35 Watt	45 Watt
Lamp wattage max.	75 Watt	75 Watt	100 Watt
Housing diameter Ø	210 mm	210 mm	280 mm
Depth incl. front part	120 mm	120 mm	120 mm
Tunnel length	190 mm	325 mm	325 mm
Tunnel width	140 mm	140 mm	140 mm
Tunnel height	85 mm	85 mm	85 mm
Combination entry for M20/M25 conduits	4	4	4
Art.-No.	1282-75	1282-76	1283-76
Inner packaging/shipping	- / 10	- / 10	- / 10

Signal cover

INNOVATION

- Protects the interior of the housing
- Three stable signal bristles and strong colouring for easy retrieval from the plastered rough ceiling.
- Serrated edge structure for a clean installation opening

NEW



For installation opening	68 mm	75 mm	80 mm
Art.-No.	1281-31	1281-32	1281-33
Inner packaging/shipping	10 / 100	10 / 100	10 / 100

System magnet

INNOVATION

- for accurate positioning during automated or manual production
- with an anti-twist device for one-gang boxes
- adhesive force 500 N (50 kg)
- Can be used for the following articles:
- HaloX® installation housing / item no. 1282-74/-75/-76 and 1283-74/-76
- B² one-gang junction boxes / item no. 1262-06, 1263-06, 1264-06
- 115 large slab ceiling box / item no. 1227-16
- End and transition bushes / item no. 1261-82/-83/-84
- Wall and ceiling transitions 30° / item no. 1261-92/-93/-94

NEW



Art.-No.	1299-69
Inner packaging/shipping	- / 10

System magnet PLUS

INNOVATION

- for correct positioning during automated production as well as automated removal and storage
- with an anti-twist device for one-gang boxes
- adhesive force 500 N (50 kg)
- Can be used for the following articles:
- HaloX® installation housing / item no. 1282-74/-75/-76 and 1283-74/-76
- B² one-gang junction boxes / item no. 1262-06, 1263-06, 1264-06
- 115 large slab ceiling box / item no. 1227-16
- End and transition bushes / item no. 1261-82/-83/-84
- Wall and ceiling transitions 30° / item no. 1261-92/-93/-94

NEW



Art.-No.	1299-70
Inner packaging/shipping	- / 10

Extension rings HaloX®

- To increase installation depth



Height	25 mm	50 mm	25 mm	50 mm
System	HaloX® 180	HaloX® 180	HaloX® 250	HaloX® 250
Max. installation depth luminaire / loudspeaker	+ 25 mm	+ 50 mm	+ 25 mm	+ 50 mm
For Art. No.	1282-xx	1282-xx	1283-xx	1283-xx
Art.-No.	1282-25	1282-50	1283-25	1283-50
Inner packaging/shipping	- / 10	- / 10	- / 10	- / 10

Replacement mineral fibreboard for HaloX® 180, HaloX® 250

- Replacement mineral fibreboard 1282-27 for housings with Art. No. 1282-71/72/73
- Replacement mineral fibreboard 1283-27 for housing with Art. No. 1283-71/73



System	HaloX® 180	HaloX® 250
Art.-No.	1282-27	1283-27
Inner packaging/shipping	- / 10	- / 10

HaloX® system – Technical information

Fire protection – minimum concrete covering according to fire resistance class

	HaloX® 100 / 180 / 250
EI 30 ceiling plastered	
EI 30 ceiling unplastered	
EI 60 ceiling plastered	
EI 60 ceiling unplastered	
EI 90 ceiling plastered	
EI 90 ceiling unplastered	

Note: Housings with Art. Nos. 1282-76 and 1283-76 must be secured in the tunnel area against floating!

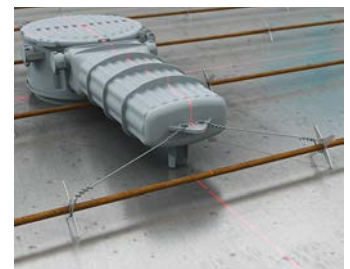

Peripheral bridges on the tunnel provide additional protection against possible floating. Re-bars can be laid on these and tightened together with the reinforcement.

Alternatively, tie lugs fitted at the end of the tunnel provide additional protection against the possible floating of the tunnel in precast concrete.

Housing volume (dm³)	HaloX® 100	HaloX® 180	HaloX® 250
Housing	1,2	3,3	6,1
with tunnel 190	2,4	4,5	-
with tunnel 325	-	5,3	8,1
Volume increase with the use of extension rings / intermediate frames in dm³			
Extension ring/intermediate frame 10	0,11	-	-
Extension ring/intermediate frame 25	0,28	0,8	1,5
Extension ring/intermediate frame 50	0,56	1,6	3,0



Installation housing ThermoX® LED

ThermoX® LED installation housing for the airtight installation of rigid and pivoting LED built-in luminaires in different ceiling constructions. The housing protects the surrounding material (vapour barrier foil, insulation etc.) against the high operating temperatures and the LED luminaires themselves from contamination, and creates an airtight separation. In combination with the thermal separation between luminaire and operating device, in this way a maximum operating lifetime is obtained.

- For installation in insulated hollow ceilings
- Retrofitting from underneath
- Toolless installation of the housing
- Guarantees airtight installation
- Rear surface structure ensures optimal heat management
- Permanent and secure retention of the luminaire in the housing



Examples of use



ThermoX® LED installation housings can be installed in seamless sub-ceiling constructions made of plywood...



...MDF board,...



...slab ceilings with single battens with overlying insulation...



...and installing plasterboard.

Temperature profiles ThermoX® LED (room temperature 25°C)

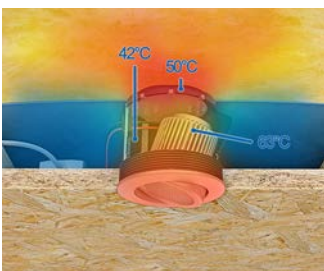

ThermoX® LED 9320-10
LED 6.6 W

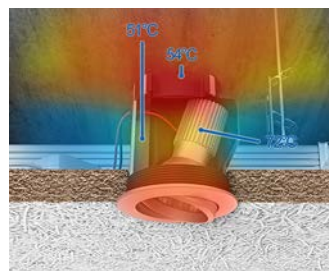

ThermoX® LED 9320-11
LED 9 W

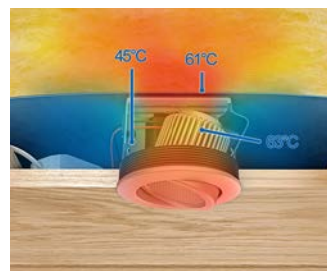

ThermoX® LED 9320-20
LED 8 W

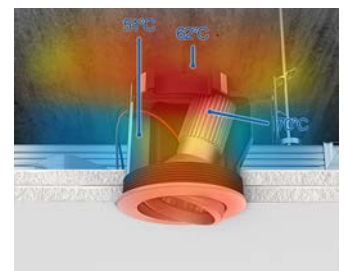

ThermoX® LED 9320-21
LED 10 W

Air-tight installation and fire-preventive protection

The ThermoX® LED housing protects the surrounding material against the extremely high temperatures that may occur during the operation of LED lamps. The housing must be installed without any surrounding insulating material coating. This protective measure can be taken both for new constructions and for retrofitting. The LED housing allows for air-tight installation because it does not destroy the vapour barrier foil that contributes to the air-tight building shell. Because of their air tightness, LED housings are also suitable for use in all suspended ceiling systems where uncontrolled air exchange is to be avoided (e.g. climate or cooling ceilings) and dustproof installation needs to be achieved (e.g. prevention of dust particles due to material removal).

Installation

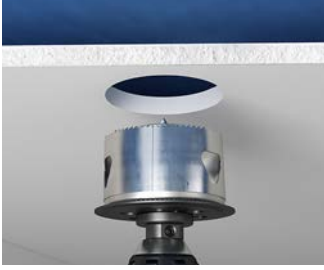

Make cut opening (e.g. with cutter PROFI – Art. No. 1081-20).



To expand existing installation openings from Ø 68 mm to Ø 74 mm using centering insert (Art. No. 1083-99).



Installation of the operating device (driver).



Feed connector from below through the entry of the LED installation housing.

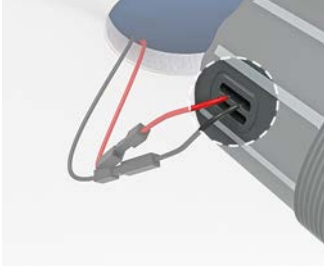

Connection of the plug-in contacts. Feed the sealing element round the cable and insert into the opening.

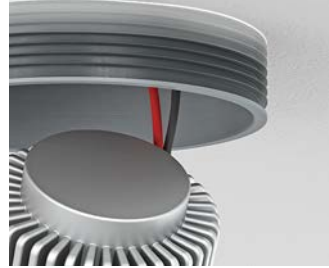

Installation of the ThermoX® LED housing in the installation opening.



Inserting the spotlight into the housing.



Rear surface structure minimises pressure on the vapour barrier and ensures optimal heat dissipation.

Technical processing instructions/standards

- use only certified (EN 60598) luminaires which are suitable for direct installation on normally flammable materials

ThermoX® LED housing

- for rigid and pivoting LED luminaires
- circumferential airtight sealing lip
- Swivel trough for alignment of the luminaire



3D animation



Depth	75 mm	95 mm	75 mm	95 mm
installation from front, cut hole Ø	74 mm	74 mm	86 mm	86 mm
Cable entries	1	3	3	3
max. installation depth for the LED luminaires	60 mm	85 mm	60 mm	85 mm
max. lamp output	6,6 Watt	9 Watt	8 Watt	10 Watt
max. ceiling exit (DA) Ø	70 mm	70 mm	81 mm	81 mm
Art.-No.	9320-10	9320-11	9320-20	9320-21
Inner packaging/shipping	- / 10	- / 10	- / 10	- / 10

Air-tightness certificate

Guaranteed airtight housing for the energy-efficient electrical installation of luminaires. The appropriate certificate can be obtained from us or downloaded from our website.





EnoX® installation housing

EnoX® housing for luminaires and other devices in ceilings and walls which are produced in a lightweight design with an air-tight building shell. Variable installation space when there is insufficient room to install electrics in the insulation level.

- Air-tight installation in line with GEG energy-saving ordinance.
- No additional installation level is necessary
- For ceilings and walls in renovated and new buildings
- Toolless cable and conduit entry
- Thermally-protected installation space 300 x 200 x 55 mm
- ECON® technology for air-tight and toolless insertion
- FX⁴ technology for fast cavity wall installation



Installation technology for low-voltage luminaires

Temperature profile for room temperature 23°C

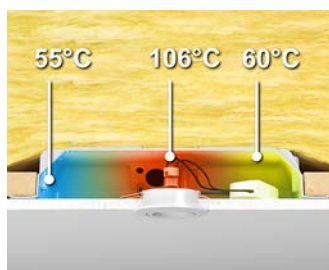

Low-voltage 35 W cool beam

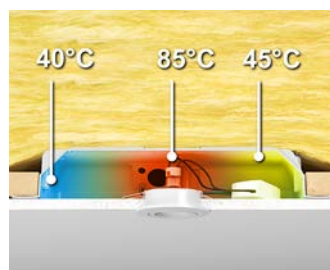

Low-voltage 35 W Alu

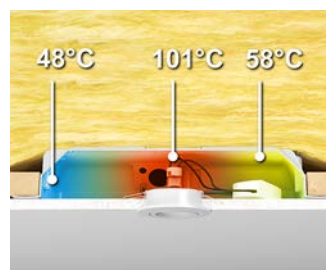

Low-voltage 50 W Alu



Example of installation

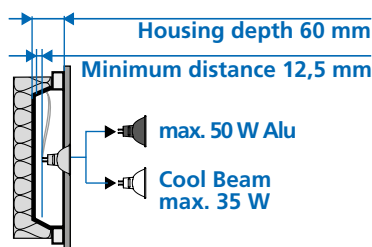
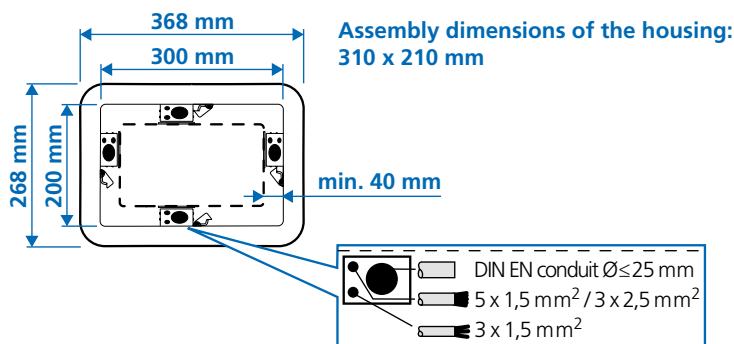

Technical processing instructions / standards

- use only certified (EN 60598) luminaires which are suitable for direct installation on normally flammable materials
- only for insulation material with heat resistance > 250 °C
- use only tested heat-resistant cables (N2 GMH 2G) and temperature-resistant terminals (e.g. T100)
- use of electrical safety transformers up to 105 VA
- max. 35 W Cool-Beam, 50 W aluminium reflector, 6.6 W LED luminaires

Examples of use



The EnoX® luminaire and loudspeaker housing can be mounted on the rafters in alternating...



...as well as inside the rafter behind the vapor barrier film...



...or mounted in a cut-out in an OSB panel.



EnoX® creates flexible space for the electrical installation in the insulation level.

EnoX® - luminaire and loudspeaker housing

- for installing luminaires, loudspeakers, displays and much more
- Minimum distance inside: min. 40 mm all round
- integrated stress relief (retention force) in accordance with DIN VDE 0606 / DIN EN 60670-1
- only for insulation material with heat resistance > 250 °C
- use only tested heat-resistant cables (N2 GMH 2G) and temperature-resistant terminals (e.g. T100)
- for installation devices up to LxW 120 x 220 mm or Ø 120 mm
- Heat distortion resistant to 220°C
- with 4 screws (FX⁴)



Product-Data

Length x Width x Depth	368 x 268 x 60 mm
Length on the inside	300 mm
Width on the inside	200 mm
Depth on the inside	57 mm
Conduit entries for DIN EN conduits up to Ø 25 mm	4
Cable entries 3 x 2.5 mm ² or 5 x 1.5 mm ²	4
Cable entries 3 x 1.5 mm ²	4
Art.-No.	9350-21
Inner packaging/shipping	- / 10

EnoX® sealing foam frame

- for fixing onto the EnoX® housing
- for sealing the moisture barrier to the housing



Art.-No.	9350-99
Inner packaging/shipping	- / 10

ThermoX® installation housing



ThermoX® installation housing for installing halogen and pivoting recessed LED luminaires in various ceiling structures. The housing protects the surrounding material (moisture barrier foil, insulation etc.) from the lamp's extreme operating temperatures and creates an air-tight closure.

- Installation housing for halogen luminaires (low voltage and high voltage)
- Fire-preventive and air-tight
- For insulated hollow ceilings
- Two different front part types
- Integrated transformer closing cap
- Ceiling exits (CE) up to Ø 86 mm
- Installation from either above or below



Installation technology for low-voltage and high-voltage luminaires

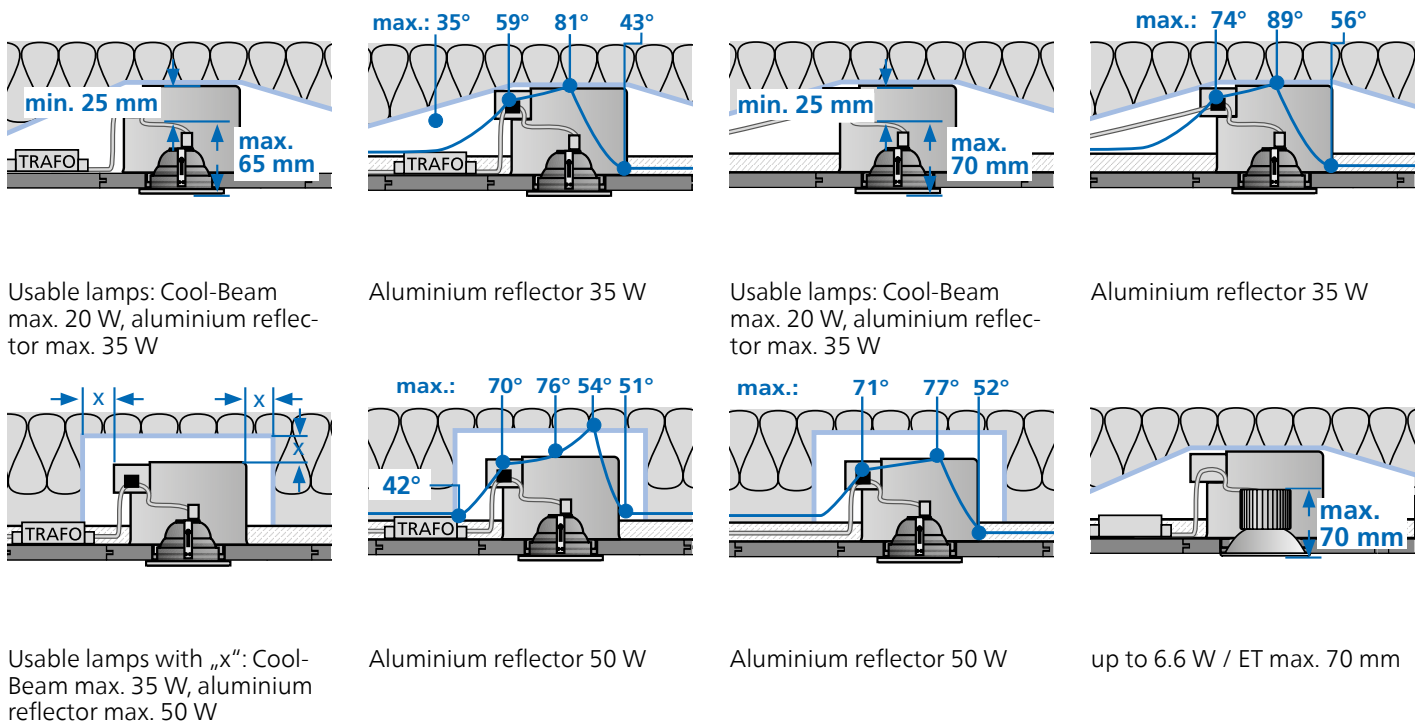

Slab ceiling / Installation from above: during ceiling installation

Cut the installation opening and insert the housing from above. The shape of the front part ensures a secure and precise fit in the boarding. After the luminaire has been installed, the opening is completely concealed.

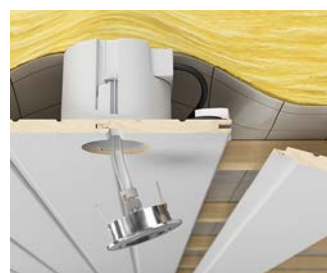

Slab ceilings / Installation from below: retrofitting

Cut an installation opening, insert the housing from below and fix in place with a fast screw attachment. The housing is attractively concealed by the KAISER decorative covering and the luminaire.



Plasterboard / Installation from below: retrofitting / smoothing

Before installation, check the required installation depth! Cut the installation opening, chamfer the bottom edge of the installation opening. Insert the housing from below and fix in place with a fast screw attachment.



Plasterboard / Installation from below: retrofitting with mineral fibreboard

Cut and chamfer the installation opening. Insert the housing from below and fix in place with a fast screw attachment. Mark opening for luminaires and cut. Smooth the joint or simply wallpaper the surface.



ThermoX® housing for low and high-voltage luminaires

- for halogen luminaires and pivoting LED luminaires
- max. installation height for low-voltage luminaire 65 mm, HV luminaire 70 mm
- Heat distortion resistant to 220°C
- lamp wattage LV: max. 35 W with AL reflector / 20 W Cool-Beam
- lamp wattage for HV luminaires max. 35 W with AL reflector (socket GU 10)
- max. LED lamp output 6.6 W
- Front can be used on both sides



Product-Data



Depth	90 mm	90 mm	90 mm
For panel thickness	7 - 40 mm	7 - 40 mm	7 - 40 mm
Ceiling exit (CE) Ø	68 mm	75 mm	82 mm
installation from front, cut hole Ø	120 mm	120 mm	120 mm
installation from rear, cut hole Ø	74 mm	79 mm	86 mm
Art.-No.	9300-01	9300-02	9300-03
Inner packaging/shipping	- / 10	- / 10	- / 10

Subject to modifications

ThermoX® system for insulated hollow ceilings

for halogen and LED built-in luminaires

ThermoX® universal housing with mineral fibreboard

- saves time - no plastering; close joint gap if necessary
- ceiling exit (CE) up to Ø 86 mm possible
- Heat distortion resistant to 220°C
- max. installation height for low-voltage luminaire 65 mm, HV luminaire 70 mm
- lamp wattage LV: max. 35 W with AL reflector / 20 W Cool-Beam
- lamp power for HV luminaires max. 35 W with AL reflector (base GU 10)
- 20 W Cool-Beam
- max. LED lamp output 6.6 W



Product-Data

Depth	90 mm
For panel thickness	7 - 40 mm
Ceiling exit (CE) Ø	0-86 mm
installation from front, cut hole Ø	120 mm
Art.-No.	9300-22
Inner packaging/shipping	- / 10

ThermoX® individual front rings

- for retrofitting or as spare part



Ceiling exit (CE) Ø	68 mm	75 mm	82 mm
Art.-No.	9300-41	9300-42	9300-43
Inner packaging/shipping	- / 10	- / 10	- / 10

ThermoX® universal front ring

- for retrofitting or as spare part
- Universal front ring



Ceiling exit (CE) Ø	0-86 mm
Art.-No.	9300-93
Inner packaging/shipping	- / 10

ThermoX® Decorative coverings

- metal with galvanised or powder coating
- only for interiors
- minimum diameter of the luminaire 79 mm with ceiling exit Ø 68 and 75 mm
- Minimum diameter of luminaire covering 86 mm with ceiling exit Ø 82 mm



Outer diameter	Ceiling exit (CE) Ø	Colour	Art.-No.	Inner packaging/shipping
125 mm	68 + 75 mm	pure white - RAL 9010	9301-01	1 / 10
125 mm	68 + 75 mm	chrome	9301-02	1 / 10
125 mm	68 + 75 mm	matt nickel	9301-03	1 / 10
125 mm	82 mm	pure white - RAL 9010	9301-11	1 / 10
125 mm	82 mm	chrome	9301-12	1 / 10
125 mm	82 mm	matt nickel	9301-13	1 / 10

Spacer

The spacer for the installation of swivelling built-in halogen and LED luminaires in various ceiling constructions. The housing ensures the necessary distance between the luminaire and the surrounding material. In this way, materials such as the moisture barrier and insulation are efficiently protected against the luminaire's high operating temperatures. This protective measure can be provided for both new buildings and retrofitting work. The housing is suitable for installation diameters between 68 and 80 mm, and can be adapted for use with different installation heights from 40 to 100 mm. After installation, the spacer stands securely on the boarding. This means that the installation diameter is fully retained and guarantees a secure fit.

- Installation in \varnothing 68 – 80 mm openings
- Maximum flexibility: Installation height from 100 – 40 mm
- Independent of boarding material and thickness
- Secure fit by means of installation on the ceiling
- Use with all standard LV / HV / LED lamps



ONE FOR ALL

Examples of use



The spacer for installing luminaires in insulated hollow ceilings can be used in jointless false ceiling constructions made of chipboard,...



...MDF board,...



...in panelled ceilings with single battens...



...and suspended ceilings clad with plasterboard.

Spacer

- for installation in insulated hollow ceilings
- retrofitting from below
- toolless mounting
- For \varnothing 68 – 80 mm installation openings
- height adjustable from 100 – 40 mm



INNOVATION



3D animation



Product-Data

Depth	100 - 40 mm
installation from front, cut hole \varnothing	68 - 80 mm
max. installation depth for the LED luminaires	95 mm
max. ceiling exit (DA) \varnothing	80 mm
Cable entries max.	4
Art.-No.	9310-10
Inner packaging/shipping	- / 10



Fire-protection boxes

- Safe, visibly certified fire protection
- HWD fire-protection boxes for fire-protection walls and ceilings, as well as shipbuilding walls
- Smokeproof and halogen-free
- Also suitable for retrofitting



Solid wood

- Maintains the F30-B to F120-B fire resistance duration
- Toolless installation thanks to rib fixing
- Innovative cable entry enables tolerance compensation of the cable route



Sealings

- Safe, visible and certified protection through the use of KAISER sealing systems for cables and conduits, as well as cable and conduit bundles
- Automatic sealing of the joints and gaps between cables – no filling and smoothing
- Europe-wide approval for fire barriers



Shipbuilding

- For ship cabin walls and ceilings B15
- Ideal for pre-assembled cables
- Certified by DNV applied
- Maintains the wall's sound insulation protection



Fire-protection housings

- Safe, certified fire-protection housings for built-in luminaires and loudspeakers in fire protection ceilings.
- Integrated fire-retardant coating maintains the fire resistance class F30 (EI30) of the ceiling in fire protection ceilings.
- They prevent fire and flue gases from spreading, thus securing escape routes in buildings
- Suitable for fire resistance from above and from below

	Fire-protection boxes 	Solid wood 	Shipbuilding boxes 	Sealings 	Fire-protection housings 
For installation accessories					
One-gang boxes	pg. 282/285	-	pg. 291	-	-
One-gang junction boxes	pg. 278/282/285	pg. 287	pg. 292	-	-
One gang boxes for thin boarding	-	-	pg. 291	-	-
One-gang junction boxes for thin boarding	-	-	pg. 292	-	-
Electronics box	pg. 283	-	-	-	-
For cable outlets					
Luminaire connection boxes	pg. 289	-	-	-	-
For luminaires and loudspeakers					
Fire protection housing	-	-	-	-	pg. 303
Housing for preventive fire protection in insulated ceilings	-	-	-	-	pg. 266
Feed-through					
Feed-through of cables	-	-	-	pg. 297	-
Feed-through of conduits	-	-	-	pg. 297	-
Feed-through of cable and conduit bundles	-	-	-	pg. 298	-
Field of application					
Wall	•	•	•	•	-
Ceiling	•	-	-	•	•
Accessories					
Fixing	pg. 146	pg. 146	pg. 146	-	-
Sealing of electrical installation conduits (air-tight and smokeproof)	pg. 33/117/302	pg. 33/117/302	pg. 33/117/302	pg. 33/117/302	pg. 33/117/302
Support connector	pg. 96/114/131/282/285	pg. 285	pg. 96/114/131/282	-	-
End cover	pg. 289	-	pg. 289	-	-

FLUSH-MOUNTING

CAVITY WALL

CONCRETE

HOUSINGS

FIRE PROTECTION

PLUGGABLE

CONNECTIVITY

CABLE GLANDS

TOOLS

SERVICE



AFS – Active Fire Stop







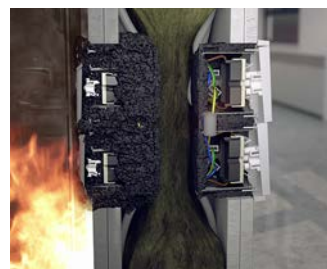
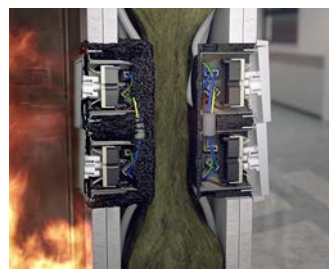
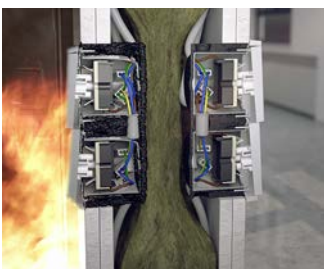
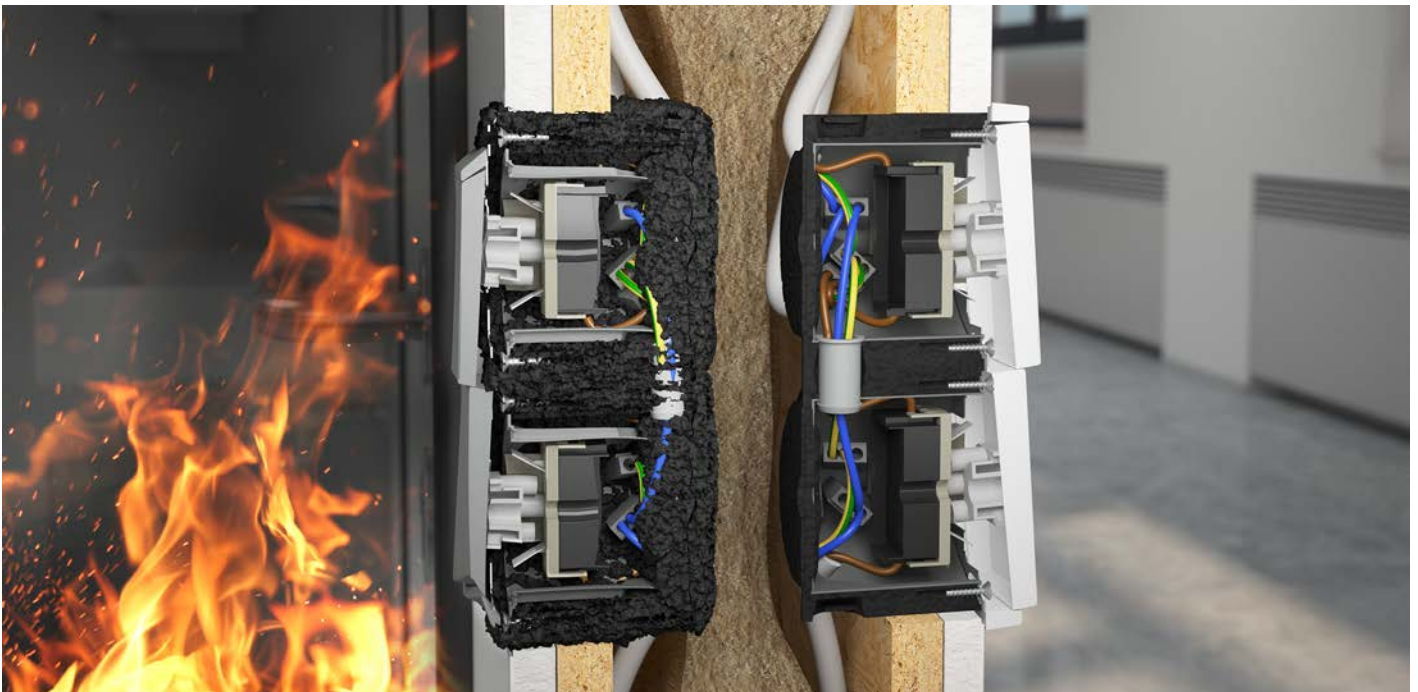

Guarantees preventive fire protection. Whether fire load from above, below, from the front or the back: the quick-active fire-retardant coating in boxes, housings and bulkheads reacts immediately in case of fire and foams out the installation opening safely. The fire resistance class F30-F120, EI30/EI60 or EI30-EI120 of the wall of or the ceiling of F30-F90 or EI30-EI90 remains unchanged. The transmission of fire and smoke is thus safely prevented. In case of fire, the KAISER AFS technology maintains the fire protection class in walls and ceilings even when installed opposite each other without encasing. The ready-to-install systems with AFS technology guarantee certified safety and smooth installation.

- Fire protection – without encasing
- Smokeproof and halogen-free
- For walls and ceilings
- For buildings and shipbuilding
- Maintains the wall's sound insulation protection

DIBt approval
General type
approval



Fire-protection systems with sound insulation protection

Certified.			 9463-01 9464-01 HWD 90 one-gang box / one-gang junction box		 9462-94 HWD 90 electronics box		 9463-03 9464-03 HWD 68+ one-gang box / one-gang junction box			 9464-05 PROTECT® Solid wood box								
Wall type / wall construction	Minimum wall requirement	Inst. levels	F30-B	F60-B	F90-B	F120-B	F30-B	F60-B	F90-B	F120-B	F30-B	F60-B	F90-B	F120-B				
Wood frame and panel construction  F30-B F60-B	Minimum wall thickness 109 mm (F30-B); 135 mm (F60-B) Wooden stand 40×60 mm (F30-B); 40×80 mm (F60-B) Boarding on both sides 1×15 mm wooden slats (e.g. OSB) F30-B with 1×9.5 mm gypsum board panel F60-B with 1×12.5 mm gypsum plaster fire protection board Wood fibre insulation 50 kg/m ³ Glass wool 14 kg/m ³ Rock wool 40 kg/m ³	30 cm from the ceiling	✓	✓			✓	not for glass wool			✓	✓						
		115 cm from the floor	✓	✓			✓	not for glass wool				✓	✓					
		105 cm from the floor	✓	✓			✓	not for glass wool				✓	✓					
		30 cm from the floor	✓	✓			✓	not for glass wool				✓	✓					
Cross laminated timber  F30-B F120-B	Minimum wall thickness Installation on one side 100 mm Opposing installation 120 mm Boarding 1×12.5 mm gypsum plaster fire protection board Minimum wall thickness Installation on one side 100 mm Opposing installation 120 mm Exposed wood quality	30 cm from the ceiling									From 1x 12.5 mm	From 1x 12.5 mm	From 1x 12.5 mm	100 mm	100 mm	120 mm	120 mm	
		115 cm from the floor										From 1x 12.5 mm	From 1x 12.5 mm	From 1x 12.5 mm	100 mm	100 mm	120 mm	120 mm
		105 cm from the floor										From 1x 12.5 mm	From 1x 12.5 mm	From 1x 12.5 mm	100 mm	100 mm	120 mm	120 mm
		30 cm from the floor										From 1x 12.5 mm	From 1x 12.5 mm	From 1x 12.5 mm	100 mm	100 mm	120 mm	120 mm
			F30 (EI30)	F60 (EI60)	F90 (EI90)	F120 (EI120)	F30 (EI30)	F60 (EI60)	F90 (EI90)	F120 (EI120)	F30 (EI30)	F60 (EI60)	F90 (EI90)					
DIN – Walls  EI30 EI120	Minimum wall thickness 100 mm Metal studs (F30 – F120) or wooden stand (F30) Boarding on both sides 2×12.5 mm gypsum plaster fire protection panels Mineral insulation > 1,000 °C	30 cm from the ceiling	✓	✓	✓	✓	✓	✓	✓	✓	✓	✓	✓					
		115 cm from the floor	✓	✓	✓	✓	✓	✓	✓	✓	✓	✓	✓	✓				
		105 cm from the floor	✓	✓	✓	✓	✓	✓	✓	✓	✓	✓	✓	✓				
		30 cm from the floor	✓	✓	✓	✓	✓	✓	✓	✓	✓	✓	✓	✓				
Approved wall (abP, abZ or aBG) 	Minimum wall thickness 100 mm Metal studs (F30 – F90) or wooden stand (F30) Boarding on both sides 2×12.5 mm cement or gypsum-bonded building panels 1×12.5 mm cement or gypsum-bonded building panel (F30) With or without insulation With glass wool abZ: general technical approval abP: general test certificate aBG: general type approval	30 cm from the ceiling	✓	From 2x 12.5 mm	✓	✓	From 2x 12.5 mm	✓	✓	✓	✓	✓	GD not for glass wool					
		115 cm from the floor	✓	From 2x 12.5 mm	✓	✓	From 2x 12.5 mm	✓	✓	✓	✓	✓	✓	GD not for glass wool				
		105 cm from the floor	✓	From 2x 12.5 mm	✓	✓	From 2x 12.5 mm	✓	✓	✓	✓	✓	✓	GD not for glass wool				
		30 cm from the floor	✓	From 2x 12.5 mm	✓	✓	From 2x 12.5 mm	✓	✓	✓	✓	✓	✓	GD not for glass wool				
Shaft wall  EI30 EI90	Metal studs boarding on one side For one-gang box 2×20 mm For one-gang junction box 2×25 mm cement or gypsum-bonded building panels F30 no insulation F60 30 kg/m ³ , > 1,000 °C F90 Termarock 100 , 100 kg/m ³	30 cm from the ceiling	✓	✓	✓													
		115 cm from the floor	✓	✓	✓													
		105 cm from the floor	✓	✓	✓													
		30 cm from the floor	✓	✓	✓													

Note: The use of the HWD 90 in shaft walls is approved in Germany by the general type approval. If the device is likely to be used in other countries, the applicable certificates, standards, guidelines or regulations must be observed.



Sound insulation value $R'w$ up to **56 dB**

Flush-mounting fire-protection box

In solid construction F30-F120 or EI30 - EI120 fire-protection walls, the fire-protection box receives the fire-protection period classification instead of fitted electrical installations. Even if the minimum wall thickness of 60 mm is not achieved in single-sided installation, or even in directly opposing installation, the fire-protection box ensures secure and smoke-proof room separation. In the event of a fire, the integrated fire-retardant coating quickly and reliably seals the installation opening, so preventing smoke and flue gas from spreading. At the same time, the risk of the fire spreading because the remaining wall is not thick enough is prevented.

- For F30-F120 or EI30-EI120 fire-protection walls
- For minimum remaining wall thicknesses ≤ 60 mm
- Also for directly opposing installation
- Variable combination connection piece for conduits up to M25
- With fire-protection cover, can be used as a junction box
- Maintains the wall's sound insulation protection



Examples of use



For F30-F120 or EI30-EI120 fire-protection walls.



For one-sided (minimum remaining wall thicknesses ≤ 60 mm) and for directly opposing installation.



Installation also possible in combinations.



With fire-protection cover (Art. No. 1184-94) can also be used as a junction box.

Flush-mounting fire-protection box

- for F30-F120 or EI30-EI120 fire-protection walls
- also for minimum remaining wall thickness ≤ 60 mm
- also for directly opposing installation
- with 4 screw domes and 2 expanding claw fields



INNOVATION



3D animation



Product-Data

Depth	60 mm
Fixing screw spacing	60 mm
Tube entries up to M25	6
Cable entries of up to $\varnothing 11.5$ mm	6
for sound insulation walls up to	56 dB
DIBt approval	Z-19.21-2413
ETA approval	ETA-18/0091
Halogen-free	Yes
	Yes / Yes
CE	Yes
Art.-No.	1564-01
Inner packaging/shipping	10 / 100

HWD 90 cavity wall boxes

HWD 90 cavity wall boxes for F30-F120 or EI30-EI120 fire-protection walls ensure certified and fire-protection compliant electrical installation. They are now also approved for timber walls in F30-B/F60-B timber frame or timber panel construction. No additional measures, such as encasing, are necessary. The intelligent AFS technology reacts immediately to fire and heat and automatically closes the installation opening. This guarantees the fire resistance class of the fire-protection wall and secures emergency routes. Use in all fire-protection walls and the fire-resistance duration of up to 120 minutes ensures maximum flexibility, even when the planning is changed. At the same time, it also maintains the wall's sound insulation requirements.

- For F30-F120 or EI30-EI120 and F30-B / F60-B fire-protection walls
- Maintains the wall's sound insulation protection
- Retrofitting also possible
- With fire-protection cover, can be used as a junction box
- Also for directly opposing installation



Processing instructions



Approved for directly opposing installation.

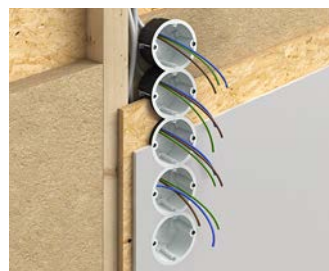

In an F30-B wall, combinations of up to 5 boxes are possible...



...in an F60-B wall, individual boxes up to a 3 box combination are possible.



The HWD 90 electronics box is also approved for the above mentioned wall constructions.

For drywall in timber construction

Since the introduction of the first fire-protection box for fire-protection walls in 2006, the range of applications has been continually expanded. HWD 90 fire-protection boxes are now also approved for timber walls in timber frame or timber panel construction. They maintain the fire protection properties of the wall with a fire-resistance duration of F30-B and F60-B. No additional measures, such as encasing, are necessary. Even if installed on the directly opposing side, the fire protection of the wall is guaranteed for 30 minutes and 60 minutes. It should be noted that for F60-B, only superstructures and installations in accordance with the timber construction guidelines are currently permitted. The HWD 90 was tested in different superstructures that occur in practice to the superstructures and installation situation described in the timber construction guidelines.





Drywall in timber construction

The proven installation has not changed. Installations directly opposing each other are possible even in timber construction up to fire resistance class F30-B (max. 5-way combination) or F60-B (max. 3-way combination). All HWD 90 type boxes maintain the sound insulation function completely up to a sound insulation level of 77 dB.

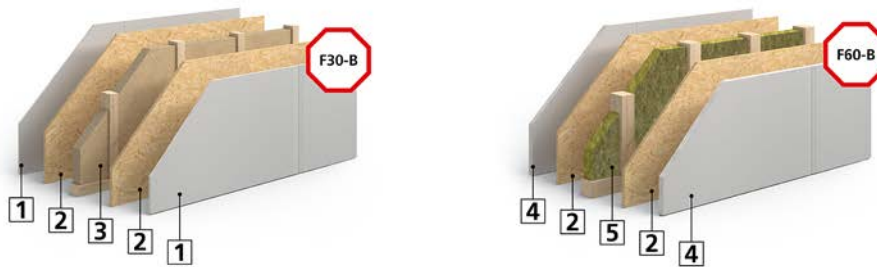

1 9.5 mm plasterboard | **2** 15 mm OSB/MDF, plywood or chipboard | **3** 40 mm wood fibre insulation, glass or rock wool 60x40 wooden beams | **4** 1x12.5 mm plasterboard fire protection board | **5** 80 mm mineral insulation > 1,000°C - 40x80 wooden beams

Note

All technical specifications correspond to the tested and approved applications. Technical deviations or changes are possible in the approvals and must be checked before use.

Installation

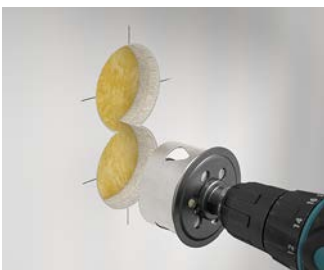

Cut an installation opening with EXPERT cutter Ø 74 mm (Art. No. 1082-40).

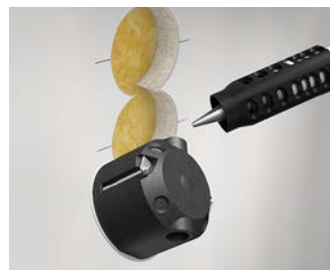

The exact opening for the cable is created smokeproof with the KAISER universal opening cutter (Art. No. 1085-80). Set the opening cutter for 3 x 1.5² to Ø 8.5, for 5 x 1.5² to Ø 9.5 and for 3 x 2.5² to Ø 9.5.

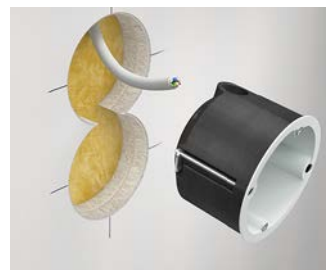

Fixing of the boxes with tried-and-tested cavity wall technology using KAISER FX⁴ technology.



The fully-insulated through-wiring of one-gang junction boxes with each other is created using the support connector (Art. No. 9060-78).

Plasterboard drywall

Minimum wall thickness: 100 mm | boarding on both sides with | min. 12.5 mm mineral non-combustible building panels (e.g. plasterboard, cement-bonded fibre boards) | min. 40 mm thick non-combustible mineral wool (e.g. glass wool, rock wool, etc) | gross density min. 14 kg/m³

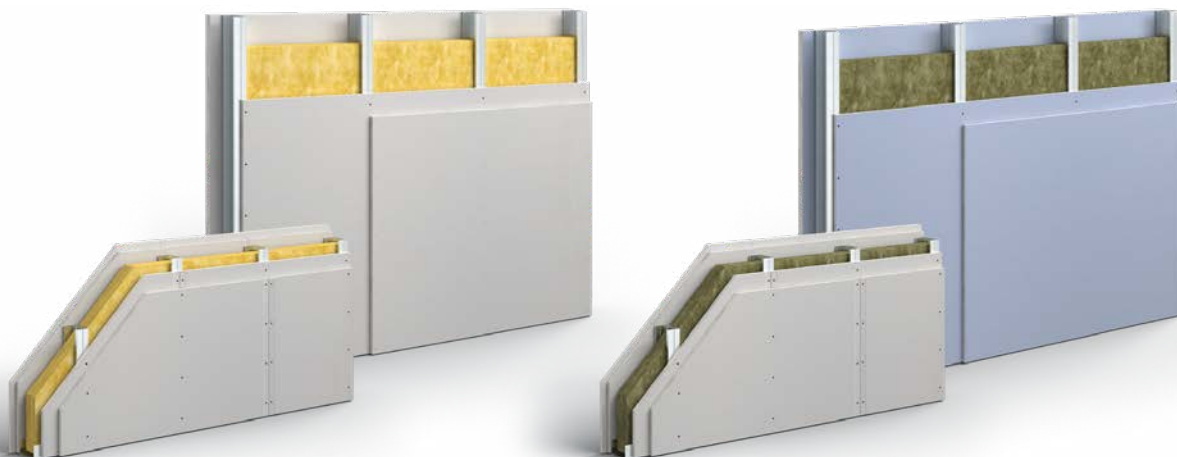

Installation shafts and ducts

The use of the HWD 90 in shaft walls is only approved in Germany by the general type approval. If the device is to be used in other countries, the applicable certificates, standards, guidelines or regulations must be observed. Steel stand | double boarding with non-combustible mineral plaster or cement-bound building panels | 2 x 20 mm (when using the one-gang box) | 2 x 25 mm (when using the one-gang junction box) | I30 - no insulation | I60 - 40 mm / 100 kg/m³, 60 mm / 50 kg/m³, 80 mm / 30 kg/m³ | I90 - 40 mm / 100 kg/m³ Termarock 100

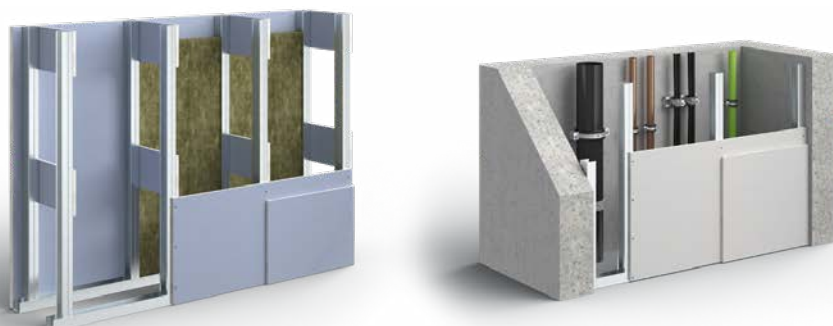

Note

In addition to the general type approval from the DIBt, we can also provide you on request with the classification report on its recognition in Austria from the IBS Test Institute for Fire Protection Technology and Safety Research in Linz. Please note: the use of the HWD 90 in shaft walls is only permitted in Germany by the general type approval. If the device is likely to be used in other countries, the applicable certificates, standards, guidelines or regulations must be observed.

FlamoX® fire-protection putty

- Building material forming an insulating layer
- for filling joints as well as bonding board materials
- Type 9400
- Working time 30 mins.
- Can be stored up to 12 months





DIBt approval	Z-19.11-1583
Contents	300 ml
	Yes
Art.-No.	9400-05
Inner packaging/shipping	- / 20

HWD 90 one-gang box

- For F30-F120 or EI30-EI120 and F30-B / F60-B fire-protection walls
- Also for I30 - I90 installation shafts / installation ducts
- also for F30-B - F60-B timber frame or timber panel construction walls



3D animation



Depth	44 mm
For panel thickness	7 - 40 mm
Cut hole Ø	74 mm
Screw spacing	60 mm
Cable entries of up to Ø 11.5 mm	2
DIBt approval	Z-19.21-1788
ETA approval	ETA-18/0091
for sound insulation walls up to	77 dB
Halogen-free	Yes
 	Yes / Yes
Art.-No.	9463-01
Inner packaging/shipping	10 / 100

HWD 90 one-gang junction box

- For F30-F120 or EI30-EI120 and F30-B / F60-B fire-protection walls
- Also for I30 - I90 installation shafts / installation ducts
- also for F30-B - F60-B timber frame or timber panel construction walls



3D animation

Depth	54,5 mm
For panel thickness	7 - 40 mm
Cut hole Ø	74 mm
Screw spacing	60 mm
Cable entries of up to Ø 11.5 mm	4
Support connectors for each package	5
DIBt approval	Z-19.21-1788
ETA approval	ETA-18/0091
Combination distance through single separation of the pre-embossed edge	71 mm
alternatively cable entry for three-phase alternating current of up to 5 x 2.5 mm possible	Yes
for sound insulation walls up to	77 dB
Halogen-free	Yes
 	Yes / Yes
Art.-No.	9464-01
Inner packaging/shipping	10 / 100

Support connector

- For fully insulated through-wiring in combinations
- Smokeproof
- For Art. No. 9464-01, 9464-15, 9464-50



Halogen-free	Yes
Art.-No.	9060-78
Inner packaging/shipping	25 / 100

Electronics box HWD 90

The HWD 90 electronics box maintains the wall's fire resistance class up to F120 or EI120 and creates installation space for electronic switch devices, data boxes, cables and terminals. The electronics box allows population with cables and also with installation conduits up to M25.

- For fire-protection walls F30-F120 or EI30-EI20
- Retrofitting is possible
- Also for use as a double box
- Extra-large terminal area for communications and network technology
- Additional space for electronic components (KNX actuators, relays, radio module, communications technology)
- Maintains the wall's sound insulation protection



Sound insulation value R'_{w} up to **77 dB**

Examples of use



The electronics box provides space for all possible installations e.g. KNX actuators, Venetian blinds relays, alarm modules and many more.



Also ideal for network connections. The generous box volume offers sufficient space for cable reserves.



The electronics box can also be used as a double box, e.g. for switch and socket combinations.



Electronic box HWD 90 can now also be used in IE30 and IE60 walls in timber frame or timber panel construction.

Electronics box HWD 90



- For cables and conduits up to M25
- Also for use as a double box
- For fire-protection walls F30-F120 or EI30-EI20
- minimum wall thickness 100 mm
- For equipment inserts and electronic components
- Tunnel twin-chamber box with enclosed separator wall and cover that can be wallpapered over.
- Can be combined with each other and also with HWD 90 one-gang junction boxes



3D animation



Product-Data

Depth	70 mm
For panel thickness	7 - 40 mm
Cut hole Ø	2 x 74 mm
Screw spacing	60 mm
Centre distance	71 mm
Conduit entries for DIN EN conduits up to Ø 25 mm	4
Cable entries up to Ø 13.5 mm	4
for sound insulation walls up to	77 dB
DIBt approval	Z-19.21-2064
ETA approval	ETA-18/0091
Halogen-free	Yes
 / 	Yes / Yes
Art.-No.	9462-94
Inner packaging/shipping	5 / 50

HWD 68+ fire-protection box



NEW

Sound insulation value $R'w$ up to **69 dB**

The new generation of KAISER fire protection boxes combine all the features of the HWD 68 and HWD 90. In addition, they cover all possible applications that occur in practice with the conduit entries. Thanks to the evaluated AFS technology, the HWD 68+ also guarantees a fire resistance duration of F30-F90 or EI30-EI90. The HWD 68+ also fulfils the F30-B-F90-B fire resistance duration in timber frame and timber panel construction as well as in cross-laminated timber construction. The HWD 68+ enables almost unrestricted and universal electrical installation in fire protection walls.

- For F30-F90 or EI30-EI90, F30-B to F90-B fire-protection walls
- Maintains the wall's sound insulation protection
- Toolless cable and conduit entry
- For installation openings \varnothing 68 mm
- For a directly opposing installation
- With fire-protection cover, can be used as a junction box

air-tight

halogen-free

IP 30

850 °C

DIBt approval
General type approval

Europe-wide
ETA Certificate

INNOVATION



3D animation

Application examples



6 cable entries up to \varnothing 13 mm and two conduit entries up to M25.

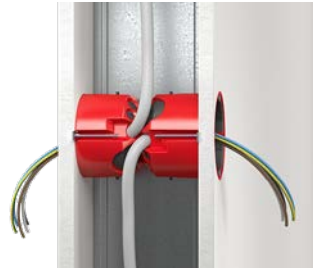

Application in walls from a wall thickness \geq 100 mm with and without insulation.



Can also be used in timber frame or timber panelled walls...



...as well as in cross-laminated timber walls.

Processing instructions

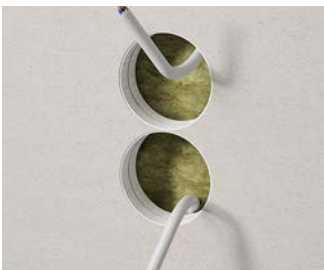

For installation openings \varnothing 68 mm and combination distance 71 mm.



Toolless cable and conduit entries.

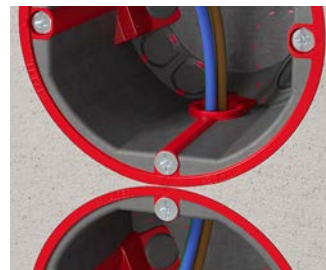

Fully insulated through-wiring of one-gang box and one-gang junction box with the support connector (Art. No. 9060-68).



Can be combined up to 5-way combinations directly opposing.

Note

All technical specifications correspond to the tested and approved applications. Technical deviations or changes are possible in the approvals and must be checked before use.

Installation



Cut Ø 68 mm installation opening using PROFI cutter (Art. No. 1081-10).

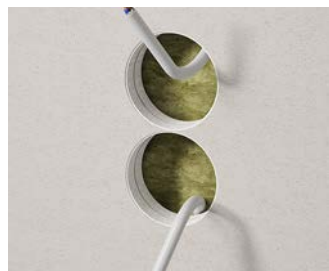

Create combinations with a distance of 71 mm.



Insert cables or conduits into the box through the appropriate openings.



Place the boxes in the installation opening and fix them by screwing on the screws.

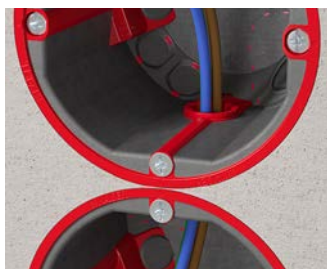

Create through-wiring for combinations with the support connector (Art. No. 9060-68).



Use installation accessories. Directly opposing combinations up to 5-way possible.

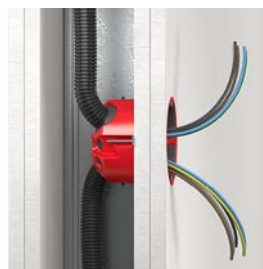

Approved for F30 fire protection walls without insulation and F60-F90 with glass wool or mineral wool insulation.



With fire-protection cover (Art. No. 1184-94) can also be used as a junction box.

HWD 68+ one-gang box

- For F30-F90 or EI30-EI90, F30-B to F90-B fire-protection walls
- also for directly opposing installation
- from wall thicknesses of 100 mm
- can be combined with each other and with the one-gang junction box

INNOVATION

NEW





HWD 68+ one-gang junction box

- For F30-F90 or EI30-EI90, F30-B to F90-B fire-protection walls
- also for directly opposing installation
- from wall thicknesses of 125 mm
- can be combined with each other and with the one-gang box

INNOVATION

NEW



Depth	49 mm	60 mm
For panel thicknesses up to	7 - 40 mm	7 - 40 mm
Cut hole Ø	68 mm	68 mm
Screw spacing	60 mm	60 mm
Support connectors for each package	5	5
DIBt approval	Z-19.21-2693	Z-19.21-2693
ETA approval	ETA-22/0129	ETA-22/0129
for sound insulation walls up to	69 dB	69 dB
Conduit entries up to Ø 13 mm	6	6
Tube entries up to M25	2	2
Halogen-free	Yes	Yes
 / 	Yes / Yes	Yes / Yes
Art.-No.	9463-03	9464-03
Inner packaging/shipping	10 / 100	10 / 100

Support connector

- For fully insulated through-wiring in combinations
- Smokeproof
- for Art. Nos. 9463-03, 9464-03



Art.-No.	9060-68
Inner packaging/shipping	25 / 100

Subject to modifications



NEW

PROTECT® solid wood fire protection one-gang junction box

The new solid wood PROTECT® one-gang junction box has been specially developed for the requirements of installation in solid wood elements / CLT. Fastening with ribs and the innovative cable entries ensure optimum and standardised installation in a solid wood element in visible wood quality without additional cutting or effort. Thanks to their arrangement and design, the innovative cable entries ensure flexible cable entry and thus compensate for the installation tolerances that arise when routing cables in the solid wood element. In addition, the PROTECT® solid wood fire protection one-gang junction box maintains the fire resistance of the solid wood element from F30-B to F120-B without the need for additional encapsulation.

- Maintains the F30-B to F120-B fire resistance duration
- For a directly opposing installation
- Toolless installation thanks to rib fixing
- Innovative cable entry enables tolerance compensation of the cable route
- Simple and toolless cable entry up to Ø 11.5 mm
- For installation openings Ø 74 mm
- Preserves the sound insulation properties of the solid wood elements



Application examples



Ideal for installation in CLT elements with visible wood quality.



For a directly opposing installation for walls ≥ 120 mm.

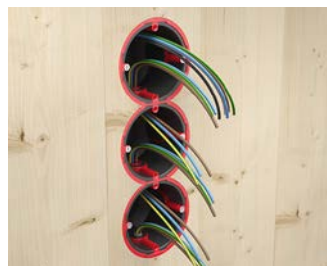

Allows up to 3-way combinations.



Can be used with fire protection cover (Art. No. 1184-94).

Processing instructions



For installation openings Ø 74 mm and combination distance 71 mm.



Toolless cable entries.



Optimum fastening thanks to ribs, even with additional boarding made of plaster-board.



The innovative cable entry ideally compensates for cable routing tolerances.

Installation



Installation openings
Ø 74 mm for combinations
with 71 mm centre distance.



Open the cable entry without
tools and insert cables up to
Ø 11.5 mm.



Align the one-gang junction
box using the markings and
insert it into the component
openings using the setting
tool.



Push in the one-gang junction
box flush up to an installation
depth of 60 mm.

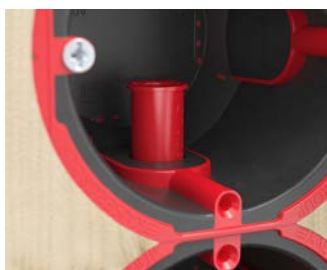

Create through-wiring for
combinations with the
support connector (Art. No.
9060-68).



Fully insulated through-wir-
ing is carried out in the cable
entry area.



Directly opposing installation
for solid wood elements ≥
120 mm.



Allows up to maximum 3-way
combinations.

PROTECT® one-gang junction box

NEW

- For F30-B to F120-B solid wood elements
- Mounting with rib fixing
- Cable entry enables tolerance compensation of the cable route
- For directly opposing installation
- Preserves the sound insulation properties of the solid wood elements



INNOVATION



3D animation

Depth	60 mm
Cut hole Ø	74 mm
Screw spacing	60 mm
Support connectors for each package	5
Sound insulation	Yes
Classification report	Yes
Cable entries of up to Ø 11.5 mm	8
For wall thicknesses of	100 mm
Combination distance by simply removing the pre-embossed edge	71 mm
Halogen-free	Yes
	Yes / Yes
Art.-No.	9464-05
Inner packaging/shipping	10 / 100

Note

All technical specifications correspond to the tested and approved applications. Technical deviations or changes are possible in the approvals and must be checked before use.



Ceiling box HWD 30

HWD 30 ceiling box guarantees F30 (EI30) to F90 (EI90) fire protection. If a fire starts, the integrated fire-retardant coating immediately generates foam and seals the opening in the ceiling. Even when retrofitted, the HWD30 ceiling box provides protection.

- For F30-F90 or EI30-EI90 fire protection ceilings
- Encasing is not necessary
- For installation of smoke detectors, motion detectors, etc.
- With a fire-protection cover, can be used as a ceiling junction box
- Retrofitting also possible



Examples of use

The HWD 30 ceiling box also lets you install for example presence and smoke detectors or LED emergency route lighting in fire-protection ceilings without endangering the fire resistance class.



Processing instructions

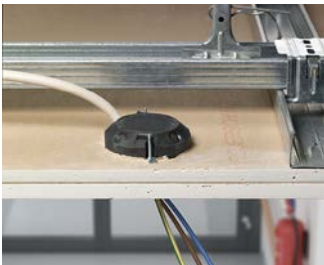

Without mineral wool, the installation corresponds to fire resistance class F30 (EI30).



If mineral wool in accordance with EN 13501 part 1 is used, the installation will withstand a fire up to fire resistance class F60 (EI60), and with Rock-wool/Termarock 100 up to fire resistance class F90 (EI90).

Allocation table for universal opening cutters



Cavity wall installation for HWD 90 fire protection boxes		Ø setting
NYM cable	3 x 1.5 mm ²	8.5
	5 x 1.5 mm ²	9.5
	3 x 2.5 mm ²	9.5
Support connector	9060-78	Connector

You can create smoke-tight cable entries with the prescribed strain relief easily and to the exact required size with the universal opening cutter (art no. 1085-80).

Installation



Cut installation opening Ø 74 mm using the cutter PROFI (Art. No. 1081-20).



Cut the exact opening for the cable with the KAISER universal opening cutter.



Fixing of the boxes with tried-and-tested cavity wall technology using KAISER FX⁴ technology.



The fire-protection cover for F30 ceilings has fire resistance class F30, for F90 ceilings it has fire resistance class F90.

Ceiling box HWD 30



- for fire protection ceilings F30-F90 or EI30-EI90
- For F30 (EI30) non-insulated fire-protection ceilings
- For F60 (EI60) fire-protection ceilings backed with mineral insulation materials in compliance with EN 13501 part 1
- for F90 (EI90) fire-protection ceilings with Rockwool/Termarock 100



Ceiling junction box HWD 30

- for fire protection ceilings F30-F90 or EI30-EI90
- For F30 (EI30) non-insulated fire-protection ceilings
- For F60 (EI60) fire-protection ceilings backed with mineral insulation materials in compliance with EN 13501 part 1
- for F90 (EI90) fire-protection ceilings with Rockwool/Termarock 100



Depth	44 mm	54,5 mm
Cut hole Ø	74 mm	74 mm
Screw spacing	60 mm	60 mm
Cable entries of up to Ø 11.5 mm	2	4
DIBt approval	Z-19.21-1788	Z-19.21-1788
ETA approval	ETA-18/0091	ETA-18/0091
Halogen-free	Yes	Yes
 	Yes / Yes	Yes / Yes
Art.-No.	9463-50	9464-50
Inner packaging/shipping	10 / 100	10 / 100

Fire-protection cover HWD 30-120

- For one-gang boxes/one-gang junction boxes and ceiling boxes HWD 90, HWD B15, HWD 30, HWD 68+ and solid wood box PROTECT®
- Fire resistance class in accordance with ceiling or wall protection (F30-F120 and EI30-EI120)



DIBt approval	Z-19.21-1788
	Yes
Art.-No.	1184-94
Inner packaging/shipping	10 / 100

Overview for the shipbuilding industry

Certified.

The HWD B15 fire protection boxes and B15 PROTECT® cable sealings ensure fire protection in walls and ceilings of fire protection class B15 on ships.

The table shows the tested areas of application. Technical deviations or changes are possible in the approvals and must be checked before use.



HWD B15 one-gang box 40 mm /
HWD B15 one-gang box /
HWD B15 one-gang junction box
for thin boarding

HWD B15 one-gang
box /
HWD B15 one-gang
junction box

B15 PROTECT®
cable sealing /
multiple sealing

Wall / ceiling structure	Minimum wall / ceiling requirement		Inst. details	B15	B15	B15	B15	B15	B15	B15	
B15 walls 	Minimum wall thickness 25 mm Sheet metal boarding on both sides For symmetrical and asymmetrical walls With and without coating	Sheathed cables up to	∅ 15 mm	✓	✓	✓	✓	✓	✓		
			∅ 12,5 mm	✓	✓	✓	✓	✓	✓	✓	
		Clamping range	0,2–40 mm	✓	✓	✓				✓	✓
			7–40 mm				✓	✓	✓	✓	✓
B15 ceiling 	Minimum ceiling thickness 30 mm Boarding on both sides For symmetrical and asymmetrical ceilings With and without coating	Sheathed cables up to	∅ 15 mm						✓		
			∅ 12,5 mm						✓	✓	
		Clamping range	0,2–40 mm							✓	✓
			7–40 mm							✓	✓



HWD B15 cavity wall box for shipbuilding walls

HWD B15 cavity wall box for category B15 partitions reacts to a fire very quickly. The integrated fire-retardant coating intumesces and reliably seals the installation opening. The HWD B15 cavity wall boxes protect against fire and smoke in the fire-protection zone and preserve the B15 function of the fire-protection wall for at least 30 minutes of flames.

- For category B15 partitions
- Encasing is not necessary
- With fire-protection cover, can be used as a junction box
- Retrofitting also possible



Certified and designed for fast installation

Expensive and time-consuming encasing, i.e. metal, is avoided with the HWD B15 cavity wall box. The user is guaranteed a certified and fast installation.



One-gang box HWD B15

· for shipbuilding walls of category B15



Product-Data

Depth	44 mm	44 mm	40 mm
For panel thickness	7 - 40 mm	0,2 - 40 mm	0,2 - 40 mm
Cut hole Ø	74 mm	74 mm	74 mm
Fixing screw spacing	60 mm	60 mm	60 mm
Conduit entries up to Ø 13 mm	4	4	4
Combination distance through single separation of the pre-embossed edge	71 mm	71 mm	71 mm
Halogen-free	Yes	Yes	Yes
	Yes / Yes	Yes / Yes	Yes / Yes
	Yes	Yes	Yes
Art.-No.	9463-15	9463-14	9461-14
Inner packaging/shipping	10 / 100	10 / 100	10 / 100



Fire-protection boxes for shipbuilding walls

One-gang junction box HWD B15

· for shipbuilding walls of category B15



Product-Data

Depth	54,5 mm	54,5 mm
For panel thickness	7 - 40 mm	0,2 - 40 mm
Cut hole Ø	74 mm	74 mm
Fixing screw spacing	60 mm	60 mm
Conduit entries up to Ø 13 mm	4	4
Support connectors for each package	5	5
Combination distance through single separation of the pre-embossed edge	71 mm	71 mm
Halogen-free	Yes	Yes
 / 	Yes / Yes	Yes / Yes
	Yes	Yes
Art.-No.	9464-15	9464-14
Inner packaging/shipping	10 / 100	10 / 100



Fire protection sealing for shipbuilding

The B15 PROTECT® fire protection sealing guarantees fire protection-related room separation in shipbuilding walls and ceilings. Fire, smoke and high temperatures are prevented from spreading due to the intumesce material that forms an insulating layer in the event of fire. Cable entries are safely, permanently and reliably sealed with the B15 PROTECT® multiple sealing and B15 PROTECT® cable sealing, thereby guaranteeing a room separation of 30 minutes.

- For ship cabin walls and ceilings B15
- For cables from Ø 4 - 12.5 mm multiple sealing
- For cables from Ø 4 - 15 mm cable sealing
- Ideal for pre-assembled cables
- Safe, certified fire protection solution
- Certified by DNV applied
- Without the use of fire protection putty
- Toolless installation
- Maintains the wall's sound insulation protection



NEW



Application examples



For cable entries through shipbuilding walls with category B15.



As well as shipbuilding ceilings B15.



Installation for wall thicknesses of 25 mm to 50 mm.



Ceiling mounting also for 25 mm to 50 mm panel thickness.

B15 PROTECT® cable sealing

- For shipbuilding walls and ceilings in the category B15 separation planes
- For pre-assembled cables
- For fire protection sealing of cable entries
- Without the use of fire protection putty
- Self-supporting sealing through insulation-forming material

INNOVATION

NEW



B15 PROTECT® multiple sealing

- For shipbuilding walls and ceilings in the category B15 separation planes
- For pre-assembled cables
- For fire protection sealing of cable entries
- Without the use of fire protection putty
- Self-supporting sealing through insulation-forming material

INNOVATION

NEW



Depth	25 mm	25 mm
Installation opening Ø	30 mm	50 mm
For sheet thicknesses	0,5 – 0,8 mm	0,5 – 0,8 mm
Cable entries Ø 4 to 9.5 mm	1	2
Cable entries Ø 4 to 12.5 mm	1	2
Cable entrie Ø 4 to 15 mm	1	-
Halogen-free	Yes	Yes
CE /	Yes / Yes	Yes / Yes
	Yes	Yes
Art.-No.	9459-14	9459-15
Inner packaging/shipping	10 / 100	5 / 50

Subject to modifications

Overview - Fire protection sealing

Certified.			 9459-01 9459-02 Cable sealing LS 90 / Conduit sealing RS 90				 9459-14 9459-15 PROTECT® cable sealing / multiple sealing									
Wall type / wall construction	Minimum wall requirement	Cable assignment	F30-B	F60-B	F90-B	F120-B	F30-B	F60-B	F90-B	F120-B						
Cross lam. timber with boarding / cross laminated / exposed timber 	Min. wall thickness 100 mm to F90-B 120 mm to F120-B Boarding 1 x 12.5 mm gypsum plaster fire protection board --- Exposed wood quality	Sheathed cables up to Ø 15 mm (with LS90) up to Ø 21 mm (RS90)	✓	✓	✓	✓ <Ø 21 mm	✓	✓	✓	✓	only 9459-14					
		Coaxial conductor without air insulation or hollow inner conductor	✓	✓	✓	✓	✓	✓	✓	✓	✓	only 9459-14				
		Data and communication line (also fibre optic cable)	✓	✓	✓	✓	✓	✓	✓	✓	✓	only 9459-14				
		Fibreglass micro conduits and electrical installation conduits M16–M25	✓	✓	✓	✓	✓	✓	✓	✓	✓	only 9459-14				
			 9459-01 9459-02 Cable sealing LS 90 / Conduit sealing RS 90				 9459-03 9459-04 Box sealing sys. DS 90 / 74 mm DS 90 / 120 mm				 9459-05 9459-06 Ceiling pen. seal sys. DS 90 / 74 mm DS 90 / 120 mm					
Wall type / wall construction	Minimum wall requirement	Cable assignment	F30 (EI30)	F60 (EI60)	F90 (EI90)		F30 (EI30)	F60 (EI60)	F90 (EI90)	F30 (EI30)	F60 (EI60)	F90 (EI90)				
Solid walls 	Minimum wall thickness 100 mm Walls made of concrete, cellular concrete, reinforced concrete or masonry walls	Sheathed cables up to Ø 29 mm (DS90 / 120 mm), up to Ø 15 mm (LS90, RS90), up to Ø 21 mm (DS90 / 74 mm)	✓	✓	✓		✓	✓	✓							
		Coaxial conductor without air insulation or hollow inner conductor	✓	✓	✓		✓	✓	✓							
		Data and communication line (also fibre optic cable)	✓	✓	✓		✓	✓	✓							
		Fibreglass micro conduits and electrical installation conduits M16–M40 (DS90/74 mm, S90 / 120 mm), M16–M25 (RS90)	✓	✓	✓		✓	✓	✓							
DIN – Walls 	Minimum wall thickness 100 mm Metal studs (F30–F90) Boarding on both sides 2 x 12.5 mm gypsum plaster fire protection panels Mineral insulation >1,000 °C	Sheathed cables up to Ø 29 mm (DS90 / 120 mm), up to Ø 15 mm (LS90, RS90), up to Ø 21 mm (DS90 / 74 mm)	✓	✓	✓		✓	✓	✓							
		Coaxial conductor without air insulation or hollow inner conductor	✓	✓	✓		✓	✓	✓							
		Data and communication line (also fibre optic cable)	✓	✓	✓		✓	✓	✓							
		Fibreglass micro conduits and electrical installation conduits M1–M40 (DS90 / 74 mm, DS90 / 120 mm), M16–M25 (RS90)	✓	✓	✓		✓	✓	✓							
Approved wall (abP, abZ or aBG) 	Min. wall thickness 100 mm Metal studs (F30–F90) Boarding on both sides 2 x 12.5 mm cement or gypsum approval bonded building panel or plasterboard / calcium silicate boards With or without insulation With glass wool abZ: general technical / abP: general test certificate / aBG: general type approval	Sheathed cables up to Ø 29 mm (DS90 / 120 mm), up to Ø 15 mm (LS90, RS90), up to Ø 21 mm (DS90 / 74 mm)	✓	✓	✓		✓ Stuffing wool ≥ 1.000 °C	✓ Stuffing wool ≥ 1.000 °C	✓ Stuffing wool ≥ 1.000 °C							
		Coaxial conductor without air insulation or hollow inner conductor	✓	✓	✓		✓ Stuffing w. ≥ 1.000 °C	✓ Stuffing w. ≥ 1.000 °C	✓ Stuffing w. ≥ 1.000 °C							
		Data and communication line (also fibre optic cable)	✓	✓	✓		✓ Stuffing w. ≥ 1.000 °C	✓ Stuffing w. ≥ 1.000 °C	✓ Stuffing w. ≥ 1.000 °C							
		Fibreglass micro conduits and electrical installation conduits M16–M40 (DS90 / 74 mm, DS90 / 120 mm), M16–M25 (RS90)	✓	✓	✓		✓ Stuffing wool ≥ 1.000 °C	✓ Stuffing wool ≥ 1.000 °C	✓ Stuffing wool ≥ 1.000 °C							
Ceiling 	Minimum ceiling thickness 150 mm Ceiling made of concrete, reinforced concrete or cellular concrete	Sheathed cables up to Ø 29 mm (DS90 / 120 mm), up to Ø 15 mm (LS90, RS90), up to Ø 21 mm (DS90 / 74 mm)								✓	✓	✓				
		Coaxial conductor without air insulation or hollow inner conductor									✓	✓	✓			
		Data and communication line (also fibre optic cable)									✓	✓	✓			
		Fibreglass micro conduits and electrical installation conduits M16 to M40									✓	✓	✓			

Cable and conduit sealing systems for walls and ceilings

KAISER cable and conduit sealing systems have been specially developed to meet the requirements of electrical installations. They are characterised by their simple, fast and safe processing. Thanks to the integrated insulating layer of fire protection material, processing is possible without additional fire protection components, which reduces the risk of incorrect installation. All fire protection systems can be used in cavity walls as well as solid walls. In addition, the DS 90/74 and DS90/120 ceiling systems can be installed in concrete ceilings. The special feature here is the installation from the ceiling upper surface, which sets the systems apart from others on the market. In the cavity wall area, the systems have another special feature compared to conventional systems. They allow cable or conduit entries to be sealed off in the wall, as a reveal is not necessary.



Application examples



The KAISER sealing system for building installation – Everything at a glance





Cable sealing system LS 90, conduit sealing system RS 90

Pipe and fire-retardant systems for safe closure of passages and entrances in fire-protection walls. The certified retardants are quick and easy to install and can even be superimposed on cables and pipes retrospectively (EI90). In addition, the cable sealing system can also be used as a wall outlet that enables the connection of electrical attachments.

- Secure, visible, certified fire sealings
- For wall feed-throughs and entries
- Without filling and smoothing
- Automatic sealing of the joints
- For cables from Ø 5 - 15 mm
- For conduits M16 - M25

halogen-free

DIBt approval
General type approval

Europe-wide
ETA Certificate



Examples of applications for cable sealing system LS 90



Wall feed-through in plaster-board fire-protection wall.



Suitable for wall entry and wall outlet in dry construction fire protection wall.



Wall feed-through in a sand-lime brick fire-protection wall.



Wall feed-through in concrete fire-protection wall.



Secure wall outlet up to EI90 for connecting electrical attachments...



...like motion detectors.

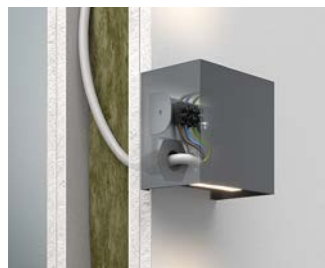

Secure wall outlet up to EI90 for connecting electrical attachments...



...like wall lights.

Cable sealing system LS 90

- for EI90 fire-protection walls
- for wall entry, wall outlet and penetration
- without use of fire-protection foam or putty
- made of intumescent material
- automatic room separation of the installation opening
- unlimited building material shelf life



3D animation



Product-Data

Min. wall thickness	100 mm
Installation opening (cavity wall)	20 mm
Installation opening (masonry)	20 mm
for cables	5 - 15 mm
ETA approval	ETA-17-0449
for sound insulation walls up to	76 dB
CE	Yes
Art.-No.	9459-01
Inner packaging/shipping	10 / 100

Examples of applications for conduit sealing system RS 90



Wall feed-through in plasterboard fire-protection wall.



M16 - M25 wall entry, in plasterboard fire-protection wall with M25 conduit.



Wall feed-through in sand-lime brick fire-protection wall.



Wall feed-through in concrete fire-protection wall.

Conduit sealing system RS 90

- for EI90 fire-protection walls
- for wall entries and feed-throughs
- without use of fire-protection foam or putty
- made of intumescent material
- automatic room separation of the installation opening
- unlimited building material shelf life



3D animation



Product-Data

Min. wall thickness	100 mm
Installation opening (cavity wall)	35 mm
Installation opening (masonry)	32 mm
for conduits	M16 - M25
ETA approval	ETA-17-0449
for sound insulation walls up to	76 dB
CE	Yes
Art.-No.	9459-02
Inner packaging/shipping	10 / 100



Sound insulation value R'_{w} up to **77 dB**

Box sealing system DS 90 / 74 mm

The box sealing system DS 90 / 74 mm for cables, cable bundles and conduits. The fire-proof and smoke-proof box sealing is quick and easy to install and can also be retrofitted on cables and conduits. The easy-to-fit product offers certified safety and ensures the fire resistance class of the wall (EI90).

- Secure, visible, certified fire sealings
- For wall feed-throughs and entries
- Automatic sealing of the joints and gaps between cables - no filling and smoothing
- Non-destructive retrofitting
- For cable bundles or individual installation conduits

halogen-free

DIBt approval
General type approval

Europe-wide
ETA Certificate



Examples of use



Use the two-part box sealing system DS 90 / 74 mm to create wall entries and feed-throughs.



Horizontal and vertical arrangement with a centre distance of 91 mm is permissible.



The box sealing system DS 90 / 74 can also be used as a spare seal (empty).



The sealing can accommodate conduits of up to M40.

Box sealing system DS 90 / 74 mm

- for EI90 fire-protection walls
- for wall entries and feed-throughs
- attachment using tried-and-tested FX⁴ metal plate screws
- with integrated sealing inserts
- ensures smoke-tight room separation (seals against cold smoke)
- unlimited building material shelf life



3D animation



Product-Data

Cut hole Ø	74 mm
Min. wall thickness	100 mm
Cable entries	Maximum population (internal diameter 40 mm)
DIBt approval for sound insulation walls up to	Z-19.53-2189 77 dB
CE	Yes
Art.-No.	9459-03
Inner packaging/shipping	10 / 100

Note

Cable population of the box sealing system DS 90 / 74 mm with all sheathed cable types recognised in Europe e.g. installation cables, data cables, telecommunication cables or fibre optic cables, as wiring bundles or as individual cables. Cable bundles can be populated up to $\varnothing \leq 40$ mm, with a maximum diameter of ≤ 15 mm for a single cable. Single cables can be used up to $\varnothing \leq 21$ mm.

Box sealing system DS 90 / 120 mm

The box sealing system DS 90 / 120 mm covers an additional range of applications in building fire protection. The increased diameter makes it possible to use a larger number of cables and electrical installation conduits and also greater diameters. With this system, it is also possible to mix the installation of conduits and cables. In addition, full population, as with the DS 90 / 74 mm, allows use of the system in all fields of building technology. Because no additional materials are used, non-destructive retrofitting is also possible. The tried-and-tested screw fixing permits clean, safe and secure installation.

- Secure, visible, certified fire sealings
- Seals wall feed-throughs
- Automatic sealing of the joints and gaps between cables - no filling and smoothing
- Non-destructive retrofitting
- Also for mixed population of bundles of cables and conduits



Sound insulation value $R'w$ up to **72 dB**

halogen-free

DIBt approval
General type approval

Europe-wide
ETA Certificate



Examples of use



Can also be used as a reserve sealing.



Full population with sheathed cables up to \varnothing 29 mm.



Mixing of cables and conduits.



Horizontal alignment is possible with a distance of 50 mm.

Box sealing system DS 90 / 120 mm

- for EI90 fire-protection walls
- attachment using tried-and-tested FX⁴ metal plate screws
- with integrated sealing inserts
- ensures smoke-tight room separation (seals against cold smoke)
- unlimited building material shelf life



3D animation



Product-Data

Cut hole \varnothing	120 mm
Min. wall thickness	100 mm
Cable entries	Maximum population (Inner diameter 74 mm)
DIBt approval for sound insulation walls up to	Z-19.53-2188 72 dB
CE	Yes
Art.-No.	9459-04
Inner packaging/shipping	- / 4



Ceiling penetration sealing systems DS 90 / 120 mm and DS 90 / 74 mm

KAISER ceiling penetration sealing systems DS 90 / 120 mm and DS 90 / 74 mm ensure that the ceiling maintains fire-resistance class EI30 - EI90. To efficiently prevent the spread of fire and flue gases through cable penetrations and electrical installation conduits through concrete or cellular concrete ceilings, their fire sealing must have the same fire-resistance class as the ceiling. The ceiling penetration sealing system DS 90 accomplishes this easily, quickly and reliably.

- Secure, visible, certified fire sealings
- Sealing especially for ceiling penetrations
- Automatic sealing without filling or smearing
- Non-destructive retrofitting
- Also for mixed population of bundles of cables and conduits
- Easy and quick installation from above

halogen-free

DIBt approval
General type approval

Europe-wide
ETA Certificate



Examples of use



Use in EI30–EI90 concrete ceilings.



Use in EI30–EI90 cellular concrete ceilings.



Mixed population of cables and conduits up to maximum population. They can also be arranged as groups with a distance of 205 mm (DS 90 / 120 mm) or 125 mm (DS 90 / 74 mm).



Mixed population of cables and conduits up to maximum population.

Ceiling penetration sealing system DS 90 / 74 mm

- for fire protection ceilings EI30 - EI90
- Easy installation without filling
- Installation on the upper side of the ceiling
- creates a smoke-tight room separation



3D animation



Product-Data

Installation opening Ø	100 mm
Ceiling thickness	150 - 300 mm
Cable entries	Maximum population (internal diameter 40 mm)
DIBt approval	Z-19.53-2189
PVC conduits up to	M40
CE	Yes
Art.-No.	9459-05
Inner packaging/shipping	1 / 12

Ceiling penetration sealing system DS 90 / 120 mm

- for fire protection ceilings EI30 - EI90
- Easy installation without filling
- Installation on the upper side of the ceiling
- creates a smoke-tight room separation



3D animation



Product-Data

Installation opening Ø	150 mm
Ceiling thickness	150 - 300 mm
Cable entries	Maximum population (Inner diameter 74 mm)
DIBt approval	Z-19.53-2188
PVC conduits up to	M50
CE	Yes
Art.-No.	9459-06
Inner packaging/shipping	- / 1

Formwork body

For preparation of installation in concrete ceilings, KAISER provides a formwork unit for matching cut-outs.

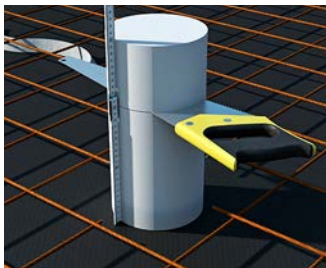

Adapt formwork unit to the ceiling thickness by cutting it to length.

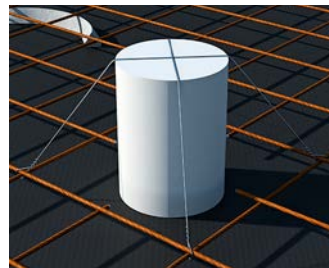

Fix formwork unit with tie wire to the reinforcement.

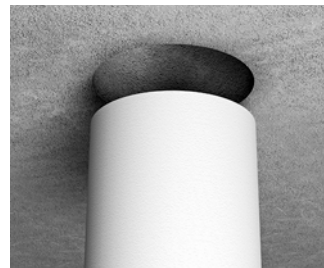

After formwork removal, remove the formwork unit from the component opening without leaving any residues.

Formwork body

- creates matching component openings
- suitable for ceiling penetration sealing systems DS 90 / 74 mm
- for ceiling thicknesses 150 - 300 mm



Formwork body

- creates matching component openings
- suitable for ceiling penetration sealing systems DS 90 / 120 mm
- for ceiling thicknesses 150 - 300 mm



Diameter	100 mm	150 mm
Ceiling thickness	150 - 300 mm	150 - 300 mm
Art.-No.	9473-95	9473-96
Inner packaging/shipping	- / 8	- / 6

Table of max. external diameter of sheathed cables (NYM cables)

The table shows examples of cables which can be used on the basis of the maximum permitted diameter. The main factor is the minimum stated standard diameter acc. to DIN VDE 0250-204.

5 x 6 ²	3 x 10 ²	5 x 10 ²	4 x 16 ²	5 x 25 ²	4 x 35 ²	7 x 2,5 ²
Ø 14,5 - 17,5 mm	Ø 14,7 - 17,7 mm	Ø 17,7 - 21,3 mm	Ø 19,0 - 23,0 mm	Ø 25,7 - 31,1 mm	Ø 25,7 - 31,1 mm	Ø 12,6 - 15,2 mm

Sealing identification tag

- universal seal identification tag
- for all KAISER sealings
- can be filled out
- in plastic, with 2 x 4.5 mm drill holes



German	Yes	Yes
English	Yes	Yes
French	Yes	Yes
Italian	Yes	-
Dutch	-	Yes
Art.-No.	9473-91	9473-92
Inner packaging/shipping	10 / 10	10 / 10

Sealing plugs 16-20

- for sealing electrical installation conduits
- ECON® technology for easy cable entry
- permanently flexible plastic



3D animation

Sealing plug	M16	M20
DIN EN conduit Ø	16 mm	20 mm
Halogen-free	Yes	Yes
Art.-No.	1040-16	1040-20
Inner packaging/shipping	25 / 100	25 / 100

Sealing plugs 25-40

- for sealing electrical installation conduits
- ECON® technology for easy cable entry
- permanently flexible plastic



3D animation

Sealing plug	M25	M32	M40
DIN EN conduit Ø	25 mm	32 mm	40 mm
Halogen-free	Yes	Yes	Yes
Art.-No.	1040-25	1040-32	1040-40
Inner packaging/shipping	25 / 100	25 / 50	- / 25

FlamoX® fire-protection housing

FlamoX® installation housings for luminaires and loudspeakers protect lives and material goods if a fire breaks out. In luminaire and loudspeaker installations in fire-protection ceilings, the integrated fire-retardant coating gives the housings the fire-protection class F30 (EI30) of the ceiling. They prevent fire and flue gases from spreading, so they secure escape routes in buildings. FlamoX® fire-protection housings provide certified security.

- Safe, certified fire-protection housings for built-in luminaires and loudspeakers
- Fast, easy fitting from the underside of the ceiling
- Suitable for fire resistance from above and below
- Installation without additional suspension
- No use of additional fire protection materials or sealing compounds



Examples of use



Fire-stop housing for recessed luminaires...



...and for loudspeakers.



Mounting in suspended fire-protection ceilings F30.

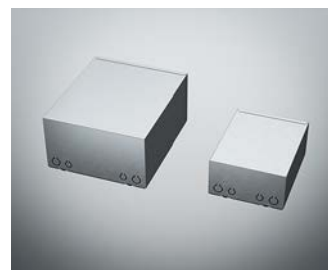

Available in two sizes for a range of uses.

FlamoX® fire-protection housing

- for luminaires and loudspeakers
- Smokeproof and halogen-free
- for fire loads from above and below
- made of galvanised sheet metal with lining made of fire-resistant coating



INNOVATION



3D animation



Product-Data

Length x Width x Height	240 x 190 x 100 mm	320 x 270 x 150 mm
For panel thickness	2 x 12,5 mm	2 x 12,5 mm
Installation height	150 mm	200 mm
Exit opening Ø	100 mm	180 mm
Max. luminaire or loudspeaker installation height	100 mm	150 mm
Tube entries up to M25	2	2
Cable entries up to Ø 13.5 mm	2	2
LED luminaires	14 Watt	34 Watt
Halogen luminaires	50 Watt	75 Watt
DIBt approval	Z-19.53-2603	Z-19.53-2603
ETA approval	ETA-20/0238	ETA-20/0238
Halogen-free	Yes	Yes
CE	Yes	Yes
Art.-No.	9435-04	9435-03
Inner packaging/shipping	- / 1	- / 1



International products

Fire-protection boxes are given the same period of fire resistance in fire-protection walls in spite of fitted electrical installations and ensure secure, smokeproof room separation. In the event of a fire, an integrated fire retardant quickly and reliably closes the installation opening and prevents flames and flue gases from escaping. This ensures that lives are saved and material goods are efficiently protected.

- For fire protection walls
- Retrofitting is possible
- For a directly opposing installation
- Can be used with fire-protection cover as a junction box



O-range® Protect³ one-gang box

- for F30-F120 or EI30-EI120 fire-protection walls
- also for directly opposing installation
- from wall thicknesses of 100 mm
- can be combined with each other and with the one-gang junction box



NEW

INNOVATION



Depth	49 mm
For panel thicknesses up to	7 - 40 mm
Cut hole Ø	68 mm
Screw spacing	60 mm
Support connectors for each package	5
ETA approval	ETA-22/0129
for sound insulation walls up to	69 dB
Cable entries of up to Ø 11.5 mm	6
Tube entries up to M25	2
Halogen-free	Yes
	Yes
Art.-No.	5431
Inner packaging/shipping	10 / 100

O-range® Protect³ one-gang junction box

- for F30-F120 or EI30-EI120 fire-protection walls
- also for directly opposing installation
- from wall thicknesses of 125 mm
- can be combined with each other and with the one-gang junction box



NEW

INNOVATION



Depth	60 mm
For panel thicknesses up to	7 - 40 mm
Cut hole Ø	68 mm
Screw spacing	60 mm
Support connectors for each package	5
ETA approval	ETA-22/0129
for sound insulation walls up to	69 dB
Cable entries of up to Ø 11.5 mm	6
Tube entries up to M25	2
Halogen-free	Yes
	Yes
Art.-No.	5439
Inner packaging/shipping	10 / 100

Quickbox Maxi HWD 90

- VKF Approval 26831
- for EI 30 - EI 90 fire walls



Length x Width x Depth	83 x 83 x 73.5 mm	145 x 83 x 73.5 mm
Cut hole Ø	83 mm	83 mm
Tube entries up to M25	2	2
Combination	1x1	2x1
/	Yes / Yes	Yes / Yes
/	Yes / Yes	Yes / Yes
Art.-No.	9499-77	9499-77.02
Inner packaging/shipping	10 / 100	- / 5

Quickbox Maxi HWD 90

- VKF Approval 26831
- for EI 30 - EI 90 fire walls



Length x Width x Depth	205 x 83 x 73.5 mm	145 x 145 x 73.5 mm	205 x 145 x 73.5 mm
Cut hole Ø	83 mm	83 mm	83 mm
Tube entries up to M25	2	4	4
Combination	3x1	2x2	3x2
/	Yes / Yes	Yes / Yes	Yes / Yes
/	Yes / Yes	Yes / Yes	Yes / Yes
Art.-No.	9499-77.03	9499-77.04	9499-77.06
Inner packaging/shipping	- / 5	- / 5	- / 5

Quickbox HWD 90

- VKF approval 21042
- for EI 30 - EI 90 fire walls



Length x Width x Depth	83 x 83 x 50 mm	145 x 83 x 50 mm	205 x 83 x 50 mm
Cut hole Ø	83 mm	83 mm	83 mm
Combination	1x1	2x1	3x1
/	Yes / Yes	Yes / Yes	Yes / Yes
/	Yes / Yes	Yes / Yes	Yes / Yes
Art.-No.	9498-77	9498-77.02	9498-77.03
Inner packaging/shipping	10 / 100	- / 5	- / 5

















AK2 modular system







- Universally combinable housing for cable support systems
- Basic housing AK2 with 10 break-out openings for cable or conduit entries, incl. 3 KBS 16 mm entries and 1 closing slider
- Front parts for system connectors from well-known manufacturers, e.g. WAGO and Wieland
- Front parts for 3 to 5-pole connectors and Keystone modules
- Front parts with SCHUKO® sockets 2- and 4-plug version
- Connectors and SCHUKO® sockets already pre-wired
- Different coloured front parts for easy differentiation of application areas
- Fixing on lower housing parts by simple latch-on
- Universal fastening solution for perforated grid and clamp attachments on many common cable support systems, such as cable trays or mesh cable trays

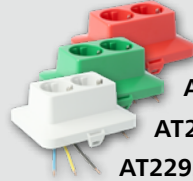

IP68 box

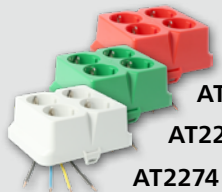
- Cable junction casing with 2-component PUR cast resin
- Delivery as a complete package ready for installation
- Ready for quick processing
- Fast commissioning
- IP68

Basic housing	Clamp attachment	Hole grid fixing
<p>Mounting on the mesh cable tray</p> 	 AT2229  +  AT2258 Clamp attachment AT2228	
<p>Mounting on/at the cable tray</p> 	 shallow plastic mounting plate AT2250  Angled plastic mounting plate AT2251  +  Shallow mounting plate AT2252 AT2249	 AT2216  +  Hole grid fixing AT2258 AT2215
<p>Accessories</p>	 Housing with box adapter AT2264  entry Ø 8–14 mm AT2256	 Blanking plug AT2257

Front part	SCHUKO® sockets	Front parts, pre-assembled (outlets with "x" pole)	Front parts, can be assembled as required
<p>3-pole connection</p>	 AT2218 AT2219 AT2293	 2 × 3pole AT7703 (WAGO) AT6021 (Wieland) 3 × 3pole AT7705 (WAGO) AT6031 (Wieland) 4 × 3pole AT7706 (WAGO) AT6041 (Wieland) 6 × 3pole AT7708 (WAGO) AT6061 (Wieland)	<p>8 × 3pole</p>  AT2278 AT2289 AT2297 AT2306
<p>4-pole connection</p>	 AT2238 AT2239 AT2274	 1/1 × 3pole AT7704 (WAGO) AT6025 (Wieland) 2/2 × 3pole AT7707 (WAGO) AT6045 (Wieland) 3/3 × 3pole AT7719 (WAGO) AT6071 (Wieland)	<p>5 × 3/4/5pole</p>  AT2275 AT2277 AT2276 AT2304
<p>4-/5-pole connection</p>	<p>–</p>	 2 × 4pole AT7722 (WAGO) AT6396 (Wieland)  2 × 5pole AT7710 (WAGO) AT6197 (Wieland) 4 × 5pole AT7721 (WAGO) AT6199 (Wieland)	

Other versions upon request.



Box for cable support systems. AK2 modular system

The AK2 modular system can cover a wide range of applications, as it offers the right solution for all installation tasks. The modular system consists of a basic box, a front part and attachment accessories in numerous variants. This allows individually configured boxes to be assembled for pluggable electrical installation.

Technical information

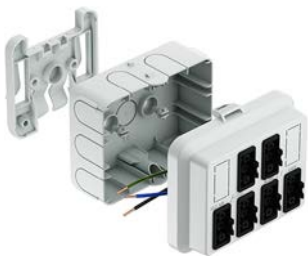

Modular AK2 Kit. Individually combinable distributor housings. System of housing base, front part and mounting adapter

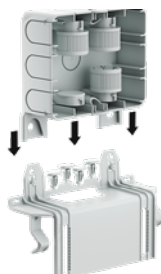

Push the AT2252 housing base onto the selected mounting adapter until it snaps in.

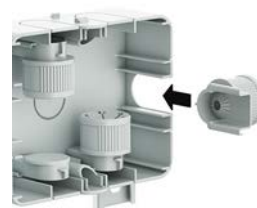

Remove the KBS cable entries, break out the pre-stamped cutout at the desired location and insert the KBS.



Front part AK2-W5 enables the assembly with up to 5 connectors with 3 to 5 poles.

Pluggable, AK2 basic box

- Each article is packaged with 3x KBS 16 mm inlets and 1 locking slider
- Matching AK2 front part can be ordered separately
- Suitable for cable support systems from well-known manufacturers



3D animation

Length x Width x Depth	120 x 95 x 40 mm	120 x 95 x 40 mm	120 x 95 x 40 mm
Fixing	Hole grid	Clamped attachment	Screw holes
Max. conductor cross section	6 mm ²	6 mm ²	6 mm ²
minimal operation temperature	- 40 °C	- 40 °C	- 40 °C
Maximum operation temperature	+ 70 °C	+ 70 °C	+ 70 °C
Housing feed-through	Breakout opening	Breakout opening	Breakout opening
Number of break-out openings	10	10	10
Protection class	IP40	IP40	IP40
Rated voltage	690 V	690 V	690 V
Colour	light grey	light grey	light grey
Halogen-free	Yes	Yes	Yes
	Yes	Yes	Yes
Art.-No.	AT2216	AT2229	AT2258
Inner packaging/shipping	- / 15	- / 100	- / 15

Pluggable, AK2 basic box

- Each article is packaged with 3x KBS 16 mm inlets and 1 locking slider
- Matching AK2 front part can be ordered separately.
- Suitable for cable support systems from well-known manufacturers



Length x Width x Depth	120 x 95 x 40 mm	120 x 95 x 40 mm	120 x 95 x 40 mm
Fixing	Flat mounting plate	Mounting plate angled	Screw holes
Max. conductor cross section	6 mm ²	6 mm ²	6 mm ²
minimal operation temperature	- 40 °C	- 40 °C	- 40 °C
Maximum operation temperature	+ 70 °C	+ 70 °C	+ 70 °C
Housing feed-through	Breakout opening	Breakout opening	Breakout opening
Number of break-out openings	10	10	10
Protection class	IP40	IP40	IP40
Rated voltage	690 V	690 V	690 V
Colour	light grey	light grey	light grey
Halogen-free	Yes	Yes	Yes
	Yes	Yes	Yes
Art.-No.	AT2250	AT2251	AT2252
Inner packaging/shipping	- / 10	- / 10	- / 50

Pluggable, AK2 basic box with box adapter

- For mounting on installation boxes.
- Matching AK2 front part can be ordered separately.



Length x Width x Depth	120 x 95 x 50 mm
Max. conductor cross section	6 mm ²
minimal operation temperature	- 40 °C
Maximum operation temperature	+ 70 °C
Housing feed-through	Breakout opening
Number of break-out openings	10
Protection class	IP40
Rated voltage	690 V
Cover attachment	Snap on
Colour	light grey
Halogen-free	Yes
Art.-No.	AT2264
Inner packaging/shipping	- / 50

KBS cable and conduit entry

- for AK2 housing
- Entry with waterproof model for cables and conduits



For conduits to DIN EN outer Ø	16 mm
for cables	8 - 14 mm
Halogen-free	Yes
Art.-No.	AT2256
Inner packaging/shipping	- / 50

Box for cable support systems. AK2 modular system

Mounting accessories for the AK2 box

- Suitable for cable support systems from well-known manufacturers



Mounting type	Hole pattern, cable tray	Clamped attachment, mesh cable tray	Flat mounting plate, cable tray
For Art. No.	AT2258	AT2229	AT2252
Installation	Horizontal / Vertical	Horizontal / Vertical	Horizontal / Vertical
Halogen-free	Yes	Yes	Yes
Art.-No.	AT2215	AT2228	AT2249
Inner packaging/shipping	- / 25	- / 30	- / 20

Universal mounting plate

- for fast and toolless "click" assembly
- Fastening clips included
- Suitable for cable support systems from well-known manufacturers
- Allows universal assembling of various components
- Quick-assembly screws for fixation of AK2 housings included

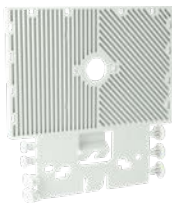

Length x Width	180 x 120 mm
Fixing	Snap on
Colour	light grey
Halogen-free	Yes
Art.-No.	AT2244
Inner packaging/shipping	- / 8

Pluggable AK2 front part, connection: 3-pole, core cable

- Prefabricated with halogen-free connection wires 2.5 mm²
- Suitable for WAGO WINSTA® MIDI or Wieland gesis® CLASSIC GST18®

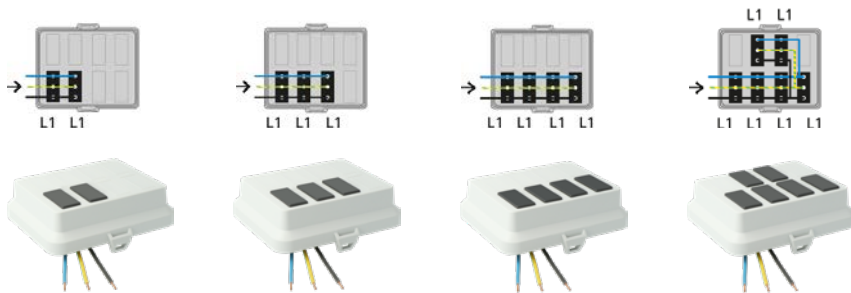

Length x Width x Depth	125 x 100 x 42 mm	125 x 100 x 42 mm	125 x 100 x 42 mm	125 x 100 x 42 mm
Poles Connection	3 pole	3 pole	3 pole	3 pole
Number of exit connectors L1	2 x	2 x	4 x	6 x
Number of poles exit connector L1	3 pole	3 pole	3 pole	3 pole
Colour of exit connectors L1	black	black	black	black
Pre-wiring	2,5 mm ²	2,5 mm ²	2,5 mm ²	2,5 mm ²
Protection class	IP20	IP20	IP20	IP20
Mounting type	Snap on	Snap on	Snap on	Snap on
Colour	light grey	light grey	light grey	light grey
Halogen-free	Yes	Yes	Yes	Yes
Art.-No. (WAGO)	AT7703	AT7705	AT7706	AT7708
Art.-No. (Wieland)	AT6021	AT6031	AT6041	AT6061
Inner packaging/shipping	- / 10	- / 10	- / 10	- / 10

Pluggable AK2 front part, connection: 4-pole, core cable

- Black and white sockets can be used for separate circuits
- Prefabricated with halogen-free connection wires 2.5 mm²
- Suitable for WAGO WINSTA® MIDI or Wieland gesis® CLASSIC GST18®

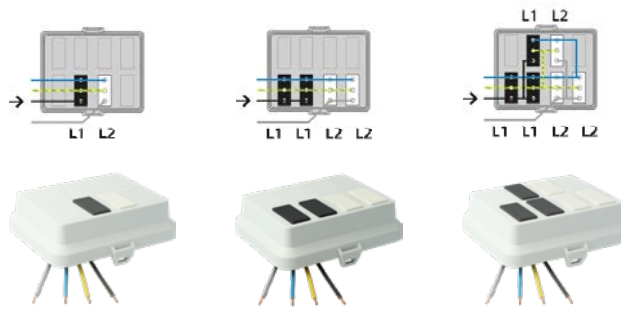

Length x Width x Depth	125 x 100 x 42 mm	125 x 100 x 42 mm	125 x 100 x 42 mm
Poles Connection	4 pole	4 pole	4 pole
Number of exit connectors L1	1 x	2 x	3 x
Number of poles exit connector L1	3 pole	3 pole	3 pole
Colour of exit connectors L1	black	black	black
Number of exit connectors L2	1 x	2 x	3 x
Number of poles exit connector L2	3 pole	3 pole	3 pole
Colour of exit connectors L2	white	white	white
Pre-wiring	2,5 mm ²	2,5 mm ²	2,5 mm ²
Protection class	IP20	IP20	IP20
Mounting type	Snap on	Snap on	Snap on
Colour	light grey	light grey	light grey
Halogen-free	Yes	Yes	Yes
Art.-No. (WAGO)	AT7704	AT7707	AT7719
Art.-No. (Wieland)	AT6025	AT6045	AT6071
Inner packaging/shipping	- / 10	- / 10	- / 10

Pluggable AK2 front part, connection: 4-pole, core cable

- For example, for the power supply and switching on and off of emergency lighting with an emergency power supply.
- Prefabricated with halogen-free connection wires 2.5 mm²
- Suitable for WAGO WINSTA® MIDI or Wieland gesis® CLASSIC GST18®

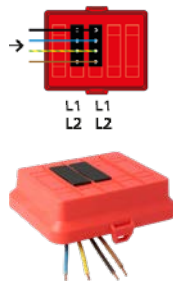

Length x Width x Depth	125 x 100 x 42 mm
Poles Connection	4 pole
Number of exit connectors	2 x
Number of poles exit connector	4 pole
Colour of exit connectors	black
Pre-wiring	2,5 mm ²
Protection class	IP20
Mounting type	Snap on
Colour	red
Halogen-free	Yes
Art.-No. (WAGO)	AT7722
Art.-No. (Wieland)	AT6396
Inner packaging/shipping	- / 10

Pluggable AK2 front part, connection: 5-pole, core cable

- Prefabricated with halogen-free connection wires 2.5 mm²
- Suitable for WAGO WINSTA® MIDI or Wieland gesis® CLASSIC GST18®

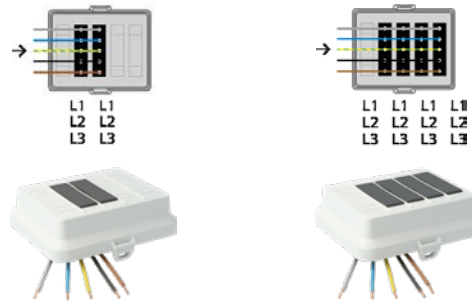

Length x Width x Depth	125 x 100 x 42 mm	125 x 100 x 42 mm
Poles Connection	5 pole	5 pole
Number of exit connectors L1/L2/L3	2 x	4 x
Number of poles exit connector L1/L2/L3	5 pole	5 pole
Colour of exit connectors L1/L2/L3	black	black
Pre-wiring	2,5 mm ²	2,5 mm ²
Protection class	IP20	IP20
Mounting type	Snap on	Snap on
Colour	light grey	light grey
Halogen-free	Yes	Yes
Art.-No. (WAGO)	AT7710	AT7721
Art.-No. (Wieland)	AT6197	AT6199
Inner packaging/shipping	- / 10	- / 10

Pluggable AK2-W5 front part

- Raised front part, equipped with 5 break-out openings for 3, 4 and 5-pole WAGO WINSTA® MIDI / Wieland gesis® CLASSIC GST18® sockets.



Length x Width x Depth	125 x 100 x 36 mm	125 x 100 x 36 mm	125 x 100 x 36 mm	125 x 100 x 36 mm
Number of break-out openings	5	5	5	5
Protection class	IP20	IP20	IP20	IP20
Mounting type	Snap on	Snap on	Snap on	Snap on
Colour	light grey	green	red	yellow
Halogen-free	Yes	Yes	Yes	Yes
	Yes	Yes	Yes	Yes
Art.-No.	AT2275	AT2277	AT2276	AT2304
Inner packaging/shipping	- / 50	- / 10	- / 10	- / 10

Pluggable AK2-W8 front part

- Raised front part, equipped with 8 break-out openings for 3-pole WAGO WINSTA® MIDI / Wieland gesis® CLASSIC GST18® sockets.

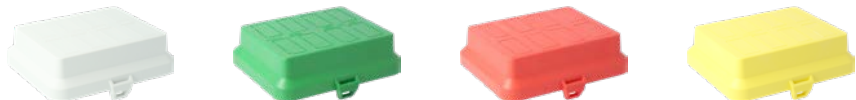

Length x Width x Depth	125 x 100 x 36 mm	125 x 100 x 36 mm	125 x 100 x 36 mm	125 x 100 x 36 mm
Number of break-out openings	8	8	8	8
Protection class	IP20	IP20	IP20	IP20
Mounting type	Snap on	Snap on	Snap on	Snap on
Colour	light grey	green	red	yellow
Halogen-free	Yes	Yes	Yes	Yes
	Yes	Yes	Yes	Yes
Art.-No.	AT2278	AT2289	AT2297	AT2306
Inner packaging/shipping	- / 50	- / 50	- / 50	- / 50

Pluggable AK2 box cover

- Suitable for all AK2 boxes
- Without breakout openings



Length x Width x Depth	125 x 100 x 15 mm
Protection class	IP40
Mounting type	Snap on
Colour	light grey
Halogen-free	Yes
Art.-No.	AT2254
Inner packaging/shipping	- / 50

Pluggable, AK2 front part with 2-fold SCHUKO® socket

- Prefabricated with halogen-free connection wires 2.5 mm²



Length x Width x Depth	125 x 100 x 50 mm	125 x 100 x 50 mm	125 x 100 x 50 mm
Poles Connection	3 pole	3 pole	3 pole
Number of SCHUKO® sockets L1	2 x	2 x	2 x
Pre-wiring	2,5 mm ²	2,5 mm ²	2,5 mm ²
Protection class	IP20	IP20	IP20
Mounting type	Snap on	Snap on	Snap on
Colour	light grey	green	red
Halogen-free	Yes	Yes	Yes
	Yes	Yes	Yes
Art.-No.	AT2293	AT2219	AT2218
Inner packaging/shipping	- / 50	- / 10	- / 10

Pluggable, AK2 front part with 4-fold SCHUKO® socket

- Socket 2+2 can be switched separately.
- Prefabricated with halogen-free connection wires 2.5 mm²

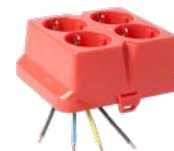

Length x Width x Depth	125 x 100 x 50 mm	125 x 100 x 50 mm	125 x 100 x 50 mm
Poles Connection	4 pole	4 pole	4 pole
Number of SCHUKO® sockets L1	2 x	2 x	2 x
Number of SCHUKO sockets L2	2 x	2 x	2 x
Pre-wiring	2,5 mm ²	2,5 mm ²	2,5 mm ²
Protection class	IP20	IP20	IP20
Mounting type	Snap on	Snap on	Snap on
Colour	light grey	green	red
Halogen-free	Yes	Yes	Yes
	Yes	Yes	Yes
Art.-No.	AT2274	AT2239	AT2238
Inner packaging/shipping	- / 25	- / 10	- / 10

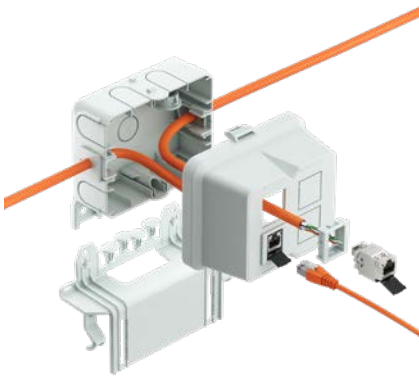

Distribution box for data networks. AK2 Data.

The components of the AK2 Data series offer a modular system for creating a network infrastructure. Based on the AK2 modular system, the enclosures are specially designed for inserting data cables and accommodating RJ45 modules in Keystone format. Installation is virtually toolless, quick and easy, enabling a wide range of applications in office buildings and industrial plants.

Pluggable, AK2 Data basic housing with mounting plate

- 2 cable entries and 1 blanking plug are included per item
- Matching AK2 front part can be ordered separately
- Suitable for cable support systems from well-known manufacturers



Length x Width x Depth	120 x 95 x 40 mm	120 x 95 x 40 mm
Fixing	Flat mounting plate	Mounting plate angled
minimal operation temperature	- 40 °C	- 40 °C
Maximum operation temperature	+ 70 °C	+ 70 °C
Housing feed-through	Breakout opening	Breakout opening
Number of break-out openings	10	10
Protection class	IP40	IP40
Rated voltage	690 V	690 V
Colour	light grey	light grey
Halogen-free	Yes	Yes
	Yes	Yes
Art.-No.	AT1960	AT1961
Inner packaging/shipping	- / 10	- / 10

Pluggable, AK2 Data basic housing

- 2 cable entries and 1 blanking plug are included per item
- Matching AK2 front part can be ordered separately
- Suitable for cable support systems from well-known manufacturers



Length x Width x Depth	120 x 95 x 40 mm
Fixing	Screw holes
minimal operation temperature	- 40 °C
Maximum operation temperature	+ 70 °C
Housing feed-through	Breakout opening
Number of break-out openings	10
Protection class	IP40
Rated voltage	690 V
Colour	light grey
Halogen-free	Yes
	Yes
Art.-No.	AT1963
Inner packaging/shipping	- / 15

Data cable entry

- for AK2 housing
- Retractable insert made from permanently elastic plastic
- for inserting a maximum of 3 data cables
- Provides support without constricting and influencing data transmission



Blanking plug

- for AK2 housing
- Seals broken-out entry openings



for cables	UTP, FTP, STP	10 mm
Halogen-free	Yes	Yes
Art.-No.	AT1966	AT2257
Inner packaging/shipping	- / 50	- / 50

Pluggable AK2 Data front part

- Front part equipped with break-out openings for adapters to accommodate Keystone modules



Length x Width x Depth	125 x 100 x 60 mm	125 x 100 x 35 mm
Number of break-out openings	4	6
Protection class	IP40	IP40
Mounting type	Snap on	Snap on
Colour	light grey	light grey
Halogen-free	Yes	Yes
	Yes	Yes
Art.-No.	AT1965	AT1964
Inner packaging/shipping	- / 25	- / 50

Adapter C, Keystone type

- can be used in AK2 Data front parts
- for mounting RJ45 modules, mounting cut-out: 19.4 x 14.9 mm
- suitable for Keystone modules from Rutenbeck, Metz Connect, Telegärtner, Digitus, 3M, and others



Adapter CL, Keystone type with label window

- can be used in AK2 Data front parts
- for mounting RJ45 modules, mounting cut-out: 19.4 x 14.9 mm
- suitable for Keystone modules from Rutenbeck, Metz Connect, Telegärtner, Digitus, 3M, and others



Length x Width x Height	28,5 x 27 x 9,6 mm	36,5 x 27 x 9,6 mm
Colour	light grey	light grey
Halogen-free	Yes	Yes
Label window	-	Yes
Art.-No.	AT1976	AT1977
Inner packaging/shipping	- / 100	- / 100



Distribution boxes for light controls. AK2 DALI.

The front parts of the AK2 DALI series offer solutions when lighting control in building installation technology is implemented using the DALI standard. Just as the lighting components have a DALI interface, the front parts are equipped with DALI connectors. This means that the AK2 modular system can be used to implement flexible applications in building automation, for example to quickly and easily wire and individually control groups of luminaires.

Pluggable AK2 front part, Wieland GST18

- Wieland gesis® CLASSIC GST18® snap-in connector
- 5-pin for DALI applications
- Connectors are self-locking, can be released with tools
- Prefabricated with halogen-free connection wires 2.5 mm².

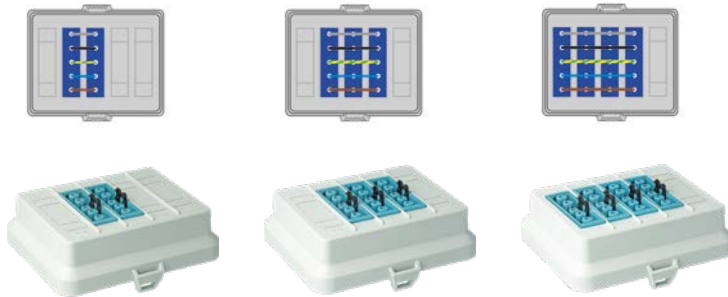

Length x Width x Depth	125 x 100 x 42 mm	125 x 100 x 42 mm	125 x 100 x 42 mm
Incoming connection	5 pole	5 pole	5 pole
Outgoing connector	2 x 5 poles, blue	3 x 5 poles, blue	4 x 5 poles, blue
Pre-wiring	2,5 mm ²	2,5 mm ²	2,5 mm ²
Protection class	IP20	IP20	IP20
Mounting type	Snap on	Snap on	Snap on
Colour	grey - RAL 7035	grey - RAL 7035	grey - RAL 7035
Halogen-free	Yes	Yes	Yes
Art.-No.	AT6510	AT6328	AT6504
Inner packaging/shipping	- / 10	- / 10	- / 10

Pluggable AK2 front part, WAGO WINSTA® MIDI

- WAGO WINSTA® MIDI snap-in connector
- 5-pin for DALI applications
- Connectors are self-locking, can be released with tools
- Prefabricated with halogen-free connection wires 2.5 mm².



Length x Width x Depth	125 x 100 x 42 mm	125 x 100 x 42 mm	125 x 100 x 42 mm
Incoming connection	5 pole	5 pole	5 pole
Outgoing connector	2 x 5 poles, blue	3 x 5 poles, blue	4 x 5 poles, blue
Pre-wiring	2,5 mm ²	2,5 mm ²	2,5 mm ²
Protection class	IP20	IP20	IP20
Mounting type	Snap on	Snap on	Snap on
Colour	grey - RAL 7035	grey - RAL 7035	grey - RAL 7035
Halogen-free	Yes	Yes	Yes
Art.-No.	AT7739	AT7746	AT7752
Inner packaging/shipping	- / 10	- / 10	- / 10

IP68BOX Outdoor Installation Set

Unpack, install, ready: complete cast resin package, fast initial operation. Watertight, unprotected outdoor installation. Including 2-component PUR cast resin in a mixing bag. When creating unprotected outdoor installations, it is important to manufacture a reliable and secure connection which will last for many years. For example, vibrations in the ground caused by traffic shouldn't affect the connection, which is designed for long-term operation – and this can be guaranteed with cast resin. Time-saving, too, because after the backfilling process, the IP68BOX can be buried and energised.

- Junction box IP65 (filled with the casting compound IP68)
- 2-component PUR cast resin in a mixing bag
- 3 M25 cable glands, clamping range Ø 11-17 mm
- Processing temperature: 0 to +35°C
- Operating temperature: - 40° to + 70°C



Processing instructions



Lay the underground cable and the cable junction box only in accordance with the legal regulations at the stipulated depth.



Remove separating strips, mix material for 3 - 4 minutes. (Bag contains 394ml, suitable for one box filling.)



Pour the casting compound into the cable junction box. Fill to 2 mm below the top edge of the cable junction box.



After closure (cover and sealing cap), the IP68BOX can be covered with earth and the power can be switched on.

IP68BOX Outdoor Installation Set

- Junction box IP65 (filled with the casting compound IP68)
- 2-component PUR cast resin in a mixing bag
- Max. conductor cross-section 6 mm²
- Nominal insulation voltage U_i: 690 V
- Connection terminals for flexible earth leads
- Sealing cap for ventilation
- Protective gloves
- mixed and solid cast resin can be disposed of in household waste



3D animation

Length x Width x Depth	95 x 95 x 55 mm
Entries M20 / M25	8
Cable gland M25	3
Protection class	IP 65/ IP 68
Halogen-free	Yes
Art.-No.	2521
Inner packaging/shipping	- / 10



Solutions for a professional fibre-to-the-home network

Fibre-optic technology is today's state-of-the-art cabling technology for telephony, Internet and television not only in the wide-area network and street distribution but also in the **building distribution right down to the residential unit**. Fibre-optic cables transmit data optically at the speed of light. At the same time, fibre-optic technology offers a far higher bandwidth compared to conventional copper transmission technology. This enables the transfer of a significantly larger amount of information or data per unit of time.

Surface-mounted fibre-optic E3S Connect® subscriber connection

For upgrading existing houses



Flush-mounted fibre-optic E3S Connect® subscriber connection

For new buildings with high design affinity



E3S Connect® building distributor

The entry point for a fibre-optic networked home

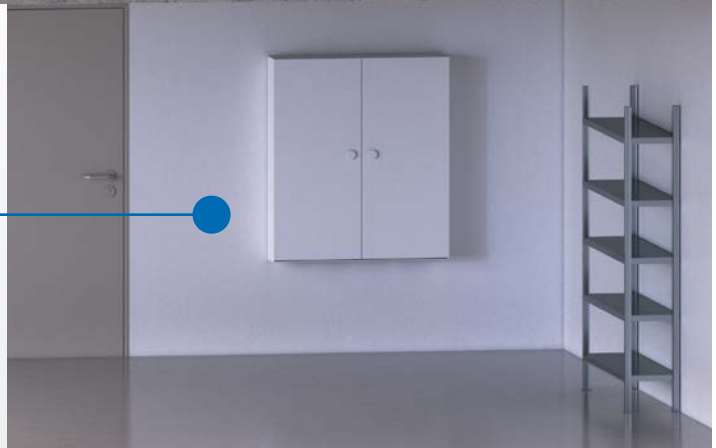

For this reason, fibre-optic technology is the data transmission solution of the present and future. In addition to ever-increasing **data volumes**, **security** and **durability** are other important aspects. Fibre-optic cables can be laid over long distances without signal amplifiers. Fibre optics are resistant to ageing and weathering and are hardly susceptible to failure. Furthermore, fibre optics are resistant to chemical influences and insensitive to electrical and magnetic influences (EMC). Almost full eavesdropping security is also ensured compared to conventional copper lines.

Fast connections with low latency, high availability and enormous investment protection are therefore the absolute strengths of end-to-end fibre-optic networking. Fibre-optic technology is also particularly suitable for networking in build-

ings (residential buildings and businesses) in order to equip them with the highest possible bandwidth in a future-proof way. **The building transition point (BTP) / fibre optic termination point (FO-TP)** forms the transition from street distribution (network level 3) to building distribution (network level 4). At this transition, the responsibility changes from the network operator to the building owner. The responsibility of the network operator ends with the splicing and positioning of the individual optical fibres in the respective splice cassettes (closure of the operator network). The installation and cabling in the building is the owner's responsibility. The building network consists of the secondary area (vertical cabling) and the tertiary cabling (horizontal cabling).

E3S Connect®

The completely pluggable solution for a building network based on fibre-optics – network level 4 (NE4)

Continuous fibre-optic in-house cabling as a purely pluggable solution, here, with E3S Connect®, KAISER offers a complete product portfolio for setting up the NE4 building network. The installation of the fibre-optic connectors and connections is very simple, splice-free and toolless.

- Complete in-house cabling from KAISER
- No splicing only plugging
- Time saving per building / project
- Solution for the electrician
- Certified GHMT system



3D animation

Examples

SFD – Detached house

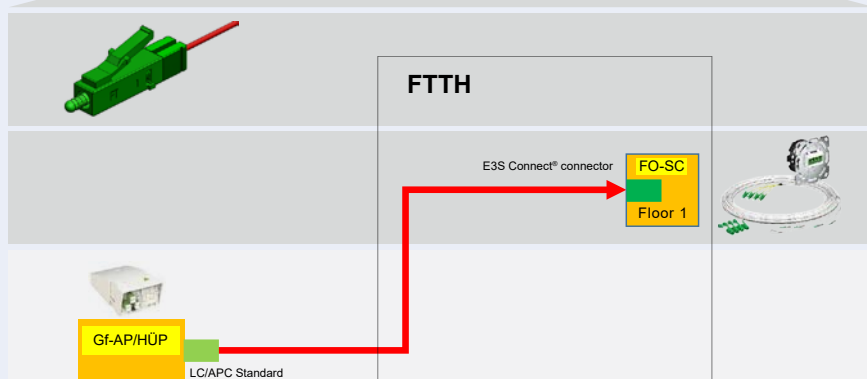

Connection to the FO-TP (Building transition point / BTP / FO-TP)



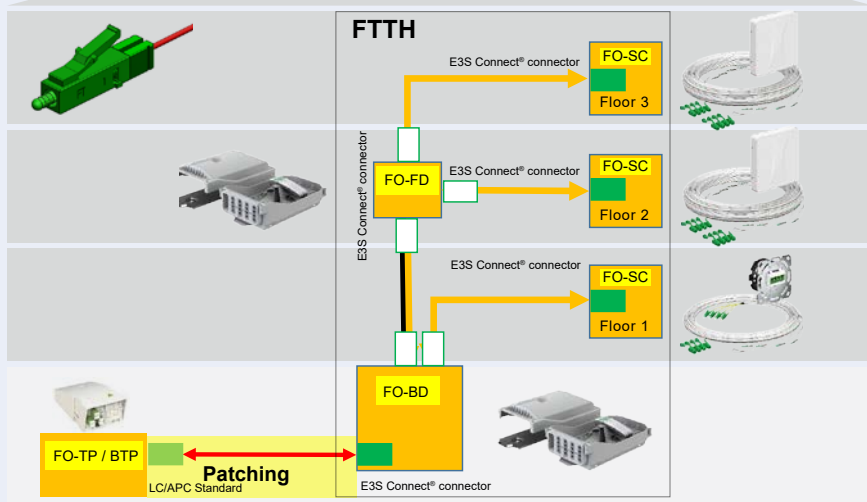

The subscriber line is connected directly to the fibre optic termination point OP-TP / BTP) via standard LC/APC connectors and laid from the basement into the respective unit. There, the fibre-optic subscriber line is connected to the E3S Connect® connector or connected to the LC/APC connectors.





MFD – Apartment building



Connection to the FO-BD (Fibre-optic building distributor)

The **fibre-optic termination point** (FO-TP / BTP) is connected to an E3S Connect® building distributor using a system patch cable. The cable for the subscriber connection can be laid bidirectionally between the unit and the building distributor. Optional (depending on building topology): It is possible to use another building distributor as a floor distributor. These are connected to each other using E3S Connect® system cables.

E3S Connect® fibre-optic subscriber line (FO-SC)				
				
	pg. 324	pg. 327	pg. 330	pg. 333
Art. No.	4252034 ... 43	4252044 ... 53	4250019 ... 28	4250029 ... 38
Network level	4	4	4	4
Type of installation	Surface-mounting	Surface-mounting	Flush-mounting	Flush-mounting
Protection class	IP 20	IP 20	IP 20	IP 20
Number of fibres	2 / 4	2 / 4	2 / 4	2 / 4
Cable length	10 – 30 m	10 – 30 m	10 – 30 m	10 – 30 m
Number of splice cassettes	1	1	1	1
Loop length (splice cassette)	180 mm	180 mm	180 mm	180 mm

E3S Connect® building distributor and accessories				
				
	Building distributor pg. 335	Patch cassette pg. 336	System cable pg. 337	Patch cable pg. 334
Art. No.	4240001	4264013	4264003 ... 12	4264001 / 4264002
Network level	4	4	4	4
Scope of delivery	Building distributor including 4x patch cassettes, 4x mounting screws, sealing material, moisture absorber	4x patch cassettes, 4x LC/APC QD	Pre-assembled E3S Connect® fibre-optic cable, 2 / 4 fibres, L=10/15/20/25/30m	E3S Connect® patch cable 2x fibres, duplex, L=2/3m

E3S Connect® accessory box	
	E3S Connect® accessory box pg. 338
Art. No.	4261011
Scope of delivery	Screwdriver, Clickcleaner 25 x connector housings, 4 x LC / APC Duplex coupler, 2 x LC / APC Quad coupler, 25 x dust cap, 25 x locking housing, Cleaning cloths, 2 x FO-TP AP, 1 x FO-TP UP, Connector end face cleaning device, Kevlar scissors Fibre stripper
	

KAISER offers a new and innovative product range for every application. With our comprehensive range, you also have the option of carrying out the complete in-house cabling as a spliceable variant or quite simply with our innovative E3S Connect® range as pluggable cabling.



E3S Connect® (pluggable)



Splicing

Whether **splicing or plugging**, all products can be easily identified by our picture identification and selected to fit exactly.

Further system and product information can be found in the KAISER Connectivity E3S Connect® main catalogue.

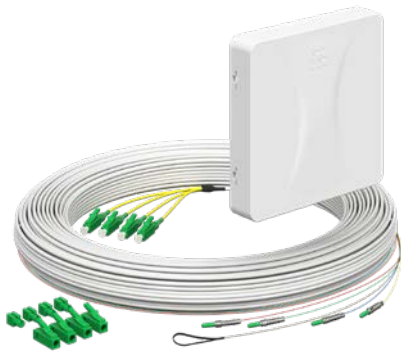

NEW

E3S Connect® (FO-SC) subscriber connection, surface-mounting with E3S fibre-optic cable for connection to the house transfer point (HTP)

The fibre-optic subscriber connection forms the termination point for fibre-optic cables in the home. The innovative and splice-free E3S Connect® system enables simple, fast expansion of the FTTH concept. The pre-assembled cables with E3S Connect® – LC/APC connectors can also be blown in, pulled in and pushed in. A handy roll-off box with different cable lengths enables precise planning and easy installation.

- Compact fibre-optic subscriber connection
- Dimensions: 85x85x16 mm (LxWxH)
- Colour similar to RAL9003 signal white
- with pre-assembled E3S fibre-optic cable in lengths of 10 - 100 m – other lengths available on request
- Available with 2 or 4 fibres
- High-quality fibre-optic cable G.657.A2 and BauPVo B2ca
- Cable retractable, insertable and blowable
- Pre-assembled cable is delivered in a handy unwinding box
- Subscriber connection enclosed

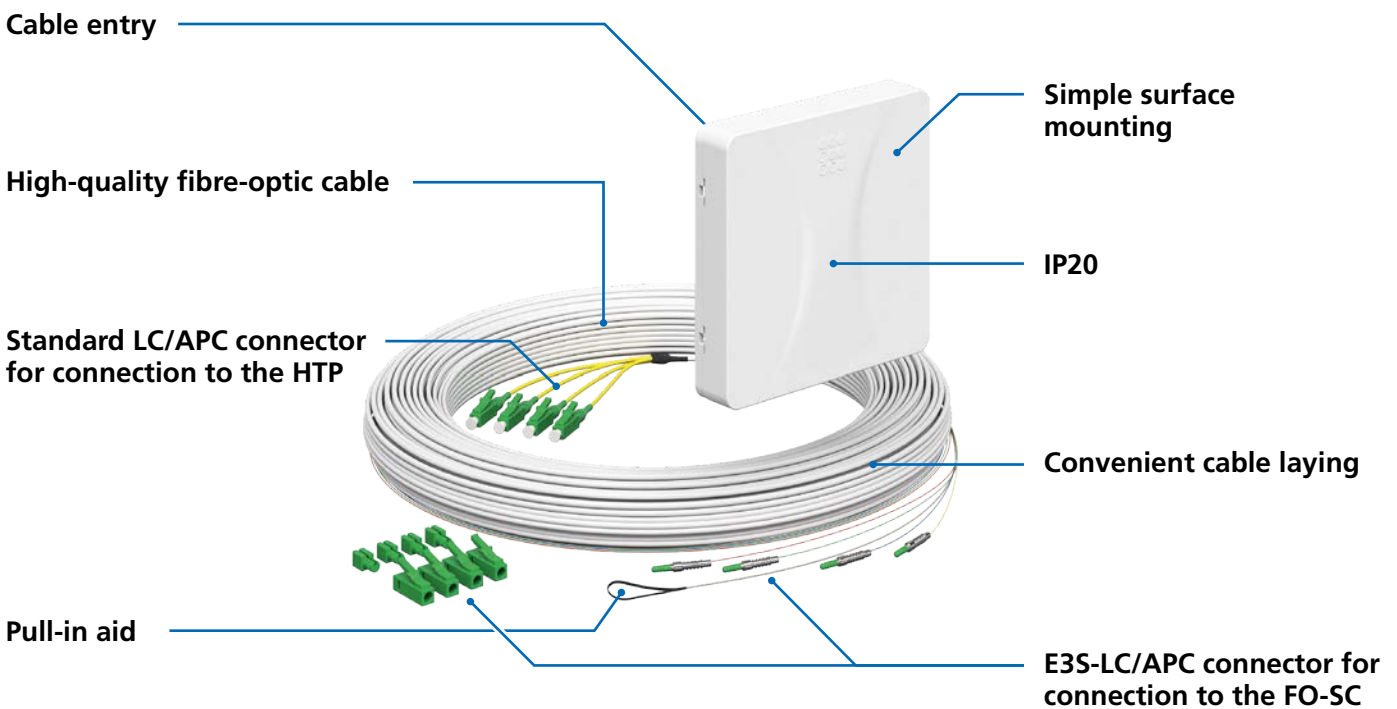

E3S Connect® (FO-SC) subscriber connection, surface-mounting, 4xF, LC/APC DX, HTP

NEW



3D animation

· Scope of delivery: FO subscriber connection, LC-APC coupling and pre-assembled E3S Connect® fibre optic cable

Cable length	i info	Art.-No.	Inner packaging/shipping
10 m	-	4252039	- / 10
15 m	-	4252040	- / 10
20 m	-	4252041	- / 10
25 m	-	4252042	- / 10
30 m	-	4252043	- / 10
35 m	-	4252068	- / 10
40 m	-	4252069	- / 10
45 m	1	4252070	- / 10
50 m	1	4252071	- / 10
55 m	1	4252072	- / 10
60 m	1	4252073	- / 10
65 m	1	4252074	- / 10
70 m	1	4252075	- / 10
75 m	1	4252076	- / 10
80 m	1	4252077	- / 10
85 m	1	4252078	- / 10
90 m	1	4252079	- / 10
95 m	1	4252080	- / 10
100 m	1	4252081	- / 10

1) Product available on request.

Length x Width x Height	85 x 85 x 16 mm
Number of fibers	4
Certificate	GHMT Channel Link (z7385b-22 ; c7385b-22)
Installation type	Surface-mounted on the wall / or on a flush-mounted box / multimedia distributor
Protection class	IP20
Impact resistance	IK07
Halogen-free	Yes
Cabel entry Ø	2,3 - 5,3 mm
Coupler LC/APC Duplex	with flange, SC Simplex footprint
Coupler Amount	2
Fibre optic line Fibre optic class	Single Mode OS2 (G.657.A2)
Fibre optic line Fibre optic color coding	4-fibres: 1=red, 2=green, 3=blue, 4=yellow
Fibre optic line ConstructionVo	B2ca according to EN50575:2014 + A1:2016
Fibre optic line Cable Ø	2,00 x 2,40 mm
Fibre optic line Traction	250 N (Installation), 100 N (Permanent)
Connector Connection to the FO-SC	E3S – LC/APC
Connector Inseration Loss	≥ 0.12dB Ø - ≤ 0.25dB Max. (Grade B)
Connector Return Loss	≥ 60 dB (Grade B)

E3S Connect® (FO-SC) subscriber connection, surface-mounting

Connection to the HTP

E3S Connect® (FO-SC) subscriber connection, surface-mounting, 2xF, LC/APC DX, HTP

NEW



3D animation

· Scope of delivery: FO subscriber connection, LC-APC coupling and pre-assembled E3S Connect® fibre optic cable

Cable length	i info	Art.-No.	Inner packaging/shipping
10 m	-	4252034	- / 10
15 m	-	4252035	- / 10
20 m	-	4252036	- / 10
25 m	-	4252037	- / 10
30 m	-	4252038	- / 10
35 m	-	4252054	- / 10
40 m	-	4252055	- / 10
45 m	1	4252056	- / 10
50 m	1	4252057	- / 10
55 m	1	4252058	- / 10
60 m	1	4252059	- / 10
65 m	1	4252060	- / 10
70 m	1	4252061	- / 10
75 m	1	4252062	- / 10
80 m	1	4252063	- / 10
85 m	1	4252064	- / 10
90 m	1	4252065	- / 10
95 m	1	4252066	- / 10
100 m	1	4252067	- / 10

1) Product available on request.

Length x Width x Height	85 x 85 x 16 mm
Number of fibers	2
Certificate	GHMT Channel Link (z7385b-22 ; c7385b-22)
Installation type	Surface-mounted on the wall / or on a flush-mounted box / multimedia distributor
Protection class	IP20
Impact resistance	IK07
Halogen-free	Yes
Coupler LC/APC Duplex	with flange, SC Simplex footprint
Coupler Amount	1
Fibre optic line Fibre optic class	Single Mode OS2 (G.657.A2)
Fibre optic line Fibre optic color coding	2-fibres: 1=red, 2=green
Fibre optic line ConstructionVo	B2ca according to EN50575:2014 + A1:2016
Fibre optic line Cable Ø	2,00 x 2,40 mm
Fibre optic line Traction	250 N (Installation), 100 N (Permanent)
Connector Connection to the FO-SC	E3S – LC/APC
Connector Inseration Loss	≥ 0.12dB Ø - ≤ 0.25dB Max. (Grade B)
Connector Return Loss	≥ 60 dB (Grade B)

E3S Connect® (FO-SC) subscriber connection, surface-mounting with E3S fibre optic cable for connection to the building distributor (FO-BD)

The fibre-optic subscriber connection forms the termination point for fibre-optic cables in the home. The innovative and splice-free E3S Connect® system enables simple, fast expansion of the FTTH concept. The pre-assembled cables with E3S Connect® – LC/APC connectors can also be blown in, pulled in and pushed in. A handy roll-off box with different cable lengths enables precise planning and easy installation.

- Compact fibre-optic subscriber connection
- Dimensions: 85x85x16 mm (LxWxH)
- Colour similar to RAL9003 signal white
- with pre-assembled E3S fibre-optic cable in lengths of 10 - 100 m – other lengths available on request
- Available with 2 or 4 fibres
- High-quality fibre-optic cable G.657.A2 and BauPVo B2ca
- Cable retractable, insertable and blowable
- Pre-assembled cable is delivered in a handy unwinding box
- Subscriber connection enclosed

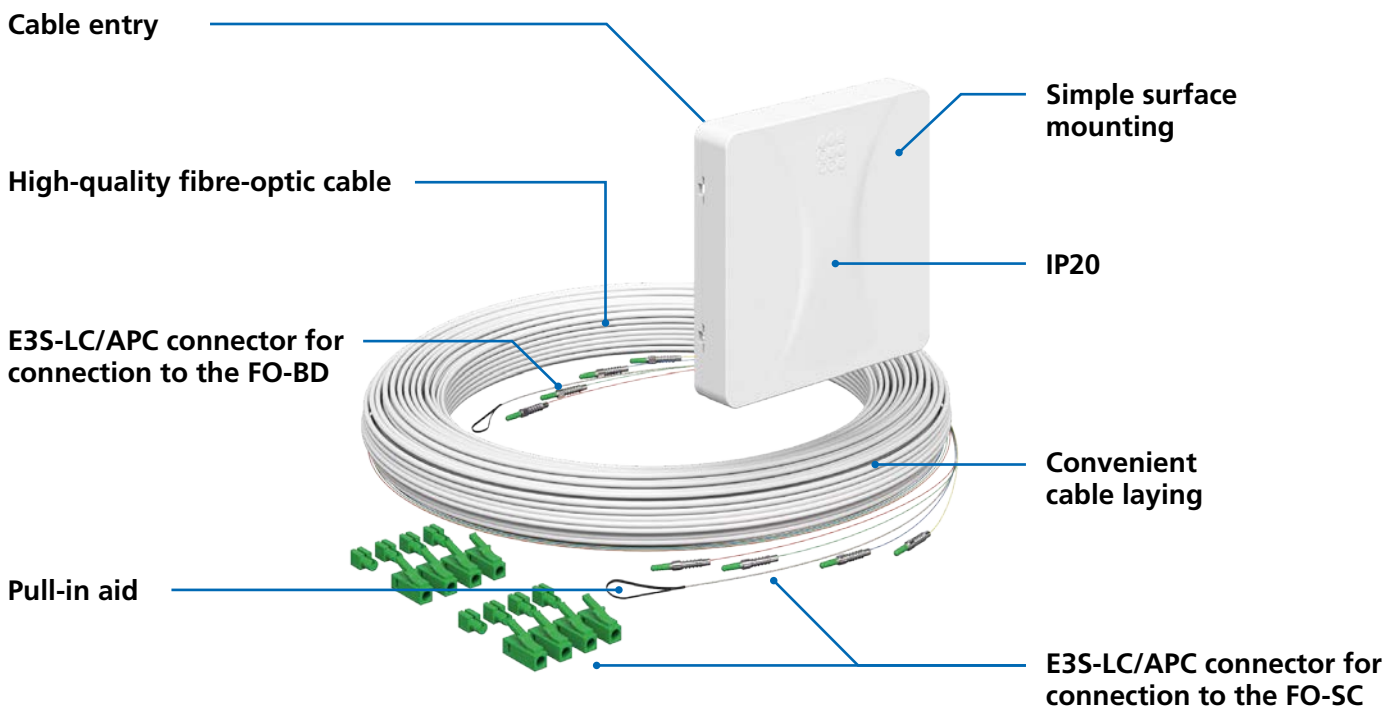

E3S Connect® (FO-SC) subscriber connection, surface-mounting

Connection to the FO-BD

E3S Connect® (FO-SC) subscriber connection, surface-mounting, 4x4, LC/APC DX, FO-BD

NEW



3D animation

· Scope of delivery: FO subscriber connection, LC-APC coupling and pre-assembled E3S Connect® fibre optic cable

Cable length	 info	Art.-No.	Inner packaging/shipping
10 m	-	4252049	- / 10
15 m	-	4252050	- / 10
20 m	-	4252051	- / 10
25 m	-	4252052	- / 10
30 m	-	4252053	- / 10
35 m	-	4252096	- / 10
40 m	-	4252097	- / 10
45 m	1	4252098	- / 10
50 m	1	4252099	- / 10
55 m	1	4252100	- / 10
60 m	1	4252101	- / 10
65 m	1	4252102	- / 10
70 m	1	4252103	- / 10
75 m	1	4252104	- / 10
80 m	1	4252105	- / 10
85 m	1	4252106	- / 10
90 m	1	4252107	- / 10
95 m	1	4252108	- / 10
100 m	1	4252109	- / 10

1) Product available on request.

Length x Width x Height	85 x 85 x 16 mm
Number of fibers	4
Certificate	GHMT Channel Link (z7479a-22 ; c7479a-22)
Installation type	Surface-mounted on the wall / or on a flush-mounted box / multimedia distributor
Protection class	IP20
Impact resistance	IK07
Halogen-free	Yes
Cable entry Ø	2,3 - 5,3 mm
Coupler LC/APC Duplex	with flange, SC Simplex footprint
Coupler Amount	1
Fibre optic line Fibre optic class	Single Mode OS2 (G.657.A2)
Fibre optic line Fibre optic color coding	4-fibres: 1=red, 2=green, 3=blue, 4=yellow
Fibre optic line ConstructionVo	B2ca according to EN50575:2014 + A1:2016
Fibre optic line Cable Ø	2,00 x 2,40 mm
Fibre optic line Traction	250 N (Installation), 100 N (Permanent)
Connector Connection to the FO-SC	E3S – LC/APC
Connector Connection to the FO-BD	E3S – LC/APC
Connector Whip length on FO-BD	approx. 100 cm connector stepped
Connector Insertion Loss	≥ 0.12dB Ø - ≤ 0.25dB Max. (Grade B)
Connector Return Loss	≥ 60 dB (Grade B)

E3S Connect® (FO-SC) subscriber connection, surface-mounting, 2xF, LC/APC DX, FO-BD

NEW



3D animation

· Scope of delivery: FO subscriber connection, LC-APC coupling and pre-assembled E3S Connect® fibre optic cable

Cable length	i info	Art.-No.	Inner packaging/shipping
10 m	-	4252044	- / 10
15 m	-	4252045	- / 10
20 m	-	4252046	- / 10
25 m	-	4252047	- / 10
30 m	-	4252048	- / 10
35 m	-	4252082	- / 10
40 m	-	4252083	- / 10
45 m	1	4252084	- / 10
50 m	1	4252085	- / 10
55 m	1	4252086	- / 10
60 m	1	4252087	- / 10
65 m	1	4252088	- / 10
70 m	1	4252089	- / 10
75 m	1	4252090	- / 10
80 m	1	4252091	- / 10
85 m	1	4252092	- / 10
90 m	1	4252093	- / 10
95 m	1	4252094	- / 10
100 m	1	4252095	- / 10

1) Product available on request.

Length x Width x Height	85 x 85 x 16 mm
Number of fibers	2
Certificate	GHMT Channel Link (z7479a-22 ; c7479a-22)
Installation type	Surface-mounted on the wall / or on a flush-mounted box / multimedia distributor
Protection class	IP20
Impact resistance	IK07
Halogen-free	Yes
Cabel entry Ø	2,3 - 5,3 mm
Coupler LC/APC Duplex	with flange, SC Simplex footprint
Coupler Amount	1
Fibre optic line Fibre optic class	Single Mode OS2 (G.657.A2)
Fibre optic line Fibre optic color coding	2-fibres: 1=red, 2=green
Fibre optic line ConstructionVo	B2ca according to EN50575:2014 + A1:2016
Fibre optic line Cable Ø	2,00 x 2,40 mm
Fibre optic line Traction	250 N (Installation), 100 N (Permanent)
Connector Connection to the FO-SC	E3S – LC/APC
Connector Connection to the FO-BD	E3S – LC/APC
Connector Whip length on FO-BD	approx. 100 cm connector stepped
Connector Inseration Loss	≥ 0.12dB Ø - ≤ 0.25dB Max. (Grade B)
Connector Return Loss	≥ 60 dB (Grade B)



NEW

E3S Connect® (FO-SC) subscriber connection, flush-mounting with E3S fibre-optic cable for connection to the house transfer point (HTP)

Innovative fibre-optic subscriber connection with an installation depth of max. 32 mm for precise flush-mounting installation in all common one-gang junction boxes. The robust metal support ring with alignment markings allows convenient mounting with screw fasteners. Perfect fibre deposit management through a rotatable and removable deposit drum on the back. Equipped with 1x LC/APC Quad coupling including shutter and dust protection. Design compatibility with all common switch manufacturers with a standardised TAE cover.

- Design-compatible with all common TAE covers
- Installation in all KAISER one-gang junction boxes
- Overlength management
- with pre-assembled E3S fibre-optic cable in lengths of 10 - 100 m – other lengths available on request
- Available with 2 or 4 fibres
- High-quality fibre-optic cable G.657.A2 and BauPVo B2ca
- Cable retractable, insertable and blowable
- Pre-assembled cable is delivered in a handy unwinding box
- Subscriber connection enclosed

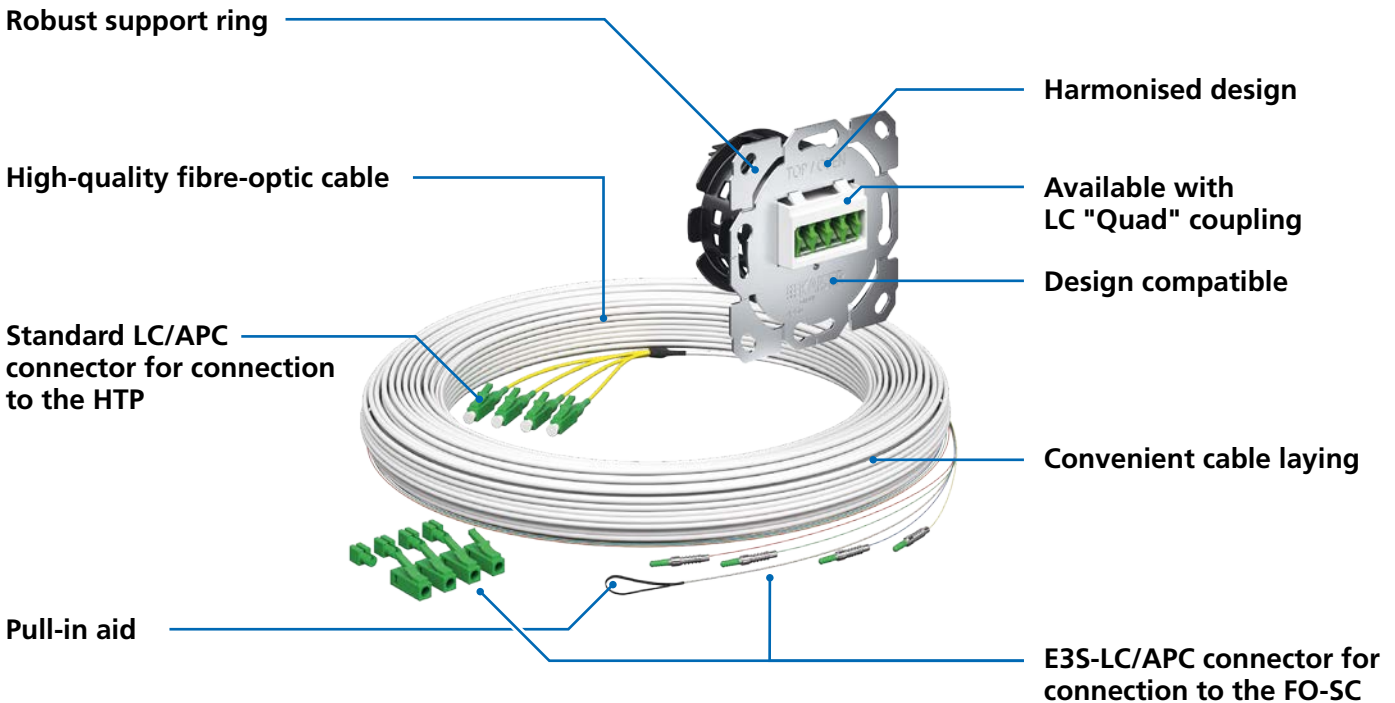

E3S Connect® (FO-SC) subscriber connection, flush-mounting, 4xF, LC/APC QD, HTP

NEW



3D animation

· Scope of delivery: FO subscriber connection, LC-APC coupling and pre-assembled E3S Connect® fibre optic cable

Cable length	i info	Art.-No.	Inner packaging/shipping
10 m	-	4250024	- / 10
15 m	-	4250025	- / 10
20 m	-	4250026	- / 10
25 m	-	4250027	- / 10
30 m	-	4250028	- / 10
35 m	-	4250053	- / 10
40 m	-	4250054	- / 10
45 m	1	4250055	- / 10
50 m	1	4250056	- / 10
55 m	1	4250057	- / 10
60 m	1	4250058	- / 10
65 m	1	4250059	- / 10
70 m	1	4250060	- / 10
75 m	1	4250061	- / 10
80 m	1	4250062	- / 10
85 m	1	4250063	- / 10
90 m	1	4250064	- / 10
95 m	1	4250065	- / 10
100 m	1	4250066	- / 10

1) Product available on request.

Number of fibers	4
Certificate	GHMT Channel Link (z7385b-22 ; c7385b-22)
Installation type	Flush-mounting
Protection class	IP20
Impact resistance	IK07
Halogen-free	Yes
Cable routing	Backside (drum)
Coupler LC/APC Duplex	with flange, SC Simplex footprint
Coupler Amount	1
Fibre optic line Fibre optic class	Single Mode OS2 (G.657.A2)
Fibre optic line Fibre optic color coding	4-fibres: 1=red, 2=green, 3=blue, 4=yellow
Fibre optic line ConstructionVo	B2ca according to EN50575:2014 + A1:2016
Fibre optic line Cable Ø	2,00 x 2,40 mm
Fibre optic line Traction	250 N (Installation), 100 N (Permanent)
Connector Connection to the FO-SC	E3S – LC/APC
Connector Insertion Loss	≥ 0.12dB Ø - ≤ 0.25dB Max. (Grade B)
Connector Return Loss	≥ 60 dB (Grade B)

E3S Connect® (FO-SC) subscriber connection, flush-mounting

Connection to the HTP

E3S Connect® (FO-SC) subscriber connection, flush-mounting, 2xF, LC/APC QD, HTP

NEW



3D animation

· Scope of delivery: FO subscriber connection, LC-APC coupling and pre-assembled E3S Connect® fibre optic cable

Cable length	i info	Art.-No.	Inner packaging/shipping
10 m	-	4250019	- / 10
15 m	-	4250020	- / 10
20 m	-	4250021	- / 10
25 m	-	4250022	- / 10
30 m	-	4250023	- / 10
35 m	-	4250039	- / 10
40 m	-	4250040	- / 10
45 m	1	4250041	- / 10
50 m	1	4250042	- / 10
55 m	1	4250043	- / 10
60 m	1	4250044	- / 10
65 m	1	4250045	- / 10
70 m	1	4250046	- / 10
75 m	1	4250047	- / 10
80 m	1	4250048	- / 10
85 m	1	4250049	- / 10
90 m	1	4250050	- / 10
95 m	1	4250051	- / 10
100 m	1	4250052	- / 10

1) Product available on request.

Number of fibers	2
Certificate	GHMT Channel Link (z7385b-22 ; c7385b-22)
Installation type	Flush-mounting
Protection class	IP20
Impact resistance	IK07
Halogen-free	Yes
Cable routing	Backside (drum)
Coupler LC/APC Duplex	with flange, SC Simplex footprint
Coupler Amount	1
Fibre optic line Fibre optic class	Single Mode OS2 (G.657.A2)
Fibre optic line Fibre optic color coding	2-fibres: 1=red, 2=green
Fibre optic line ConstructionVo	B2ca according to EN50575:2014 + A1:2016
Fibre optic line Cable Ø	2,00 x 2,40 mm
Fibre optic line Traction	250 N (Installation), 100 N (Permanent)
Connector Connection to the FO-SC	E3S – LC/APC
Connector Inseration Loss	≥ 0.12dB Ø - ≤ 0.25dB Max. (Grade B)
Connector Return Loss	≥ 60 dB (Grade B)

E3S Connect® (FO-SC) subscriber connection, flush-mounting with E3S fibre-optic cable for connection to the building distributor (FO-BD)

Innovative fibre-optic subscriber connection with an installation depth of max. 32 mm for precise flush-mounting installation in all common one-gang junction boxes. The robust metal support ring with alignment markings allows convenient mounting with screw fasteners. Perfect fibre deposit management through a rotatable and removable deposit drum on the back. Equipped with 1x LC/APC Quad coupling including shutter and dust protection. Design compatibility with all common switch manufacturers with a standardised TAE cover.

- Design-compatible with all common TAE covers
- Installation in all KAISER one-gang junction boxes
- Overlength management
- with pre-assembled E3S fibre-optic cable in lengths of 10 - 100 m – other lengths available on request
- Available with 2 or 4 fibres
- High-quality fibre-optic cable G.657.A2 and BauPVo B2ca
- Cable retractable, insertable and blowable
- Pre-assembled cable is delivered in a handy unwinding box
- Subscriber connection enclosed



Robust support ring

High-quality fibre-optic cable

E3S-LC/APC connector for connection to the FO-BD

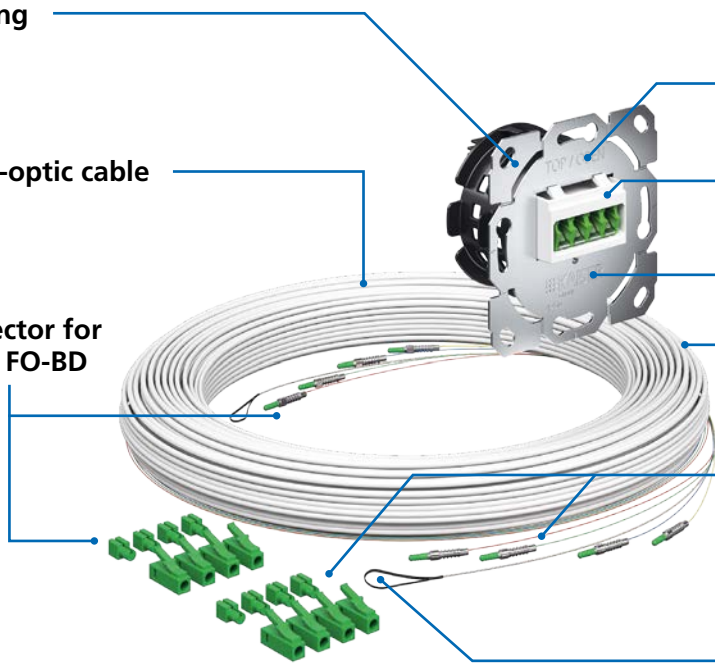

Harmonised design

Available with LC "Quad" coupling

Design compatible

Convenient cable laying

E3S-LC/APC connector for connection to the FO-SC

Pull-in aid

E3S Connect® (FO-SC) subscriber connection, flush-mounting

Connection to the FO-BD

E3S Connect® (FO-SC) subscriber connection, flush-mounting, 4x4, LC/APC QD, FO-BD

NEW



3D animation

· Scope of delivery: FO subscriber connection, LC-APC coupling and pre-assembled E3S Connect® fibre optic cable

Cable length	i info	Art.-No.	Inner packaging/shipping
10 m	-	4250034	- / 10
15 m	-	4250035	- / 10
20 m	-	4250036	- / 10
25 m	-	4250037	- / 10
30 m	-	4250038	- / 10
35 m	-	4250081	- / 10
40 m	-	4250082	- / 10
45 m	1	4250083	- / 10
50 m	1	4250084	- / 10
55 m	1	4250085	- / 10
60 m	1	4250086	- / 10
65 m	1	4250087	- / 10
70 m	1	4250088	- / 10
75 m	1	4250089	- / 10
80 m	1	4250090	- / 10
85 m	1	4250091	- / 10
90 m	1	4250092	- / 10
95 m	1	4250093	- / 10
100 m	1	4250094	- / 10

1) Product available on request.

Number of fibers	4
Certificate	GHMT Channel Link (z7479a-22 ; c7479a-22)
Installation type	Flush-mounting
Protection class	IP20
Impact resistance	IK07
Halogen-free	Yes
Cable routing	Backside (drum)
Coupler LC/APC Duplex	with flange, SC Simplex footprint
Coupler Amount	1
Fibre optic line Fibre optic class	Single Mode OS2 (G.657.A2)
Fibre optic line Fibre optic color coding	4-fibres: 1=red, 2=green, 3=blue, 4=yellow
Fibre optic line ConstructionVo	B2ca according to EN50575:2014 + A1:2016
Fibre optic line Cable Ø	2,00 x 2,40 mm
Fibre optic line Traction	250 N (Installation), 100 N (Permanent)
Connector Connection to the FO-SC	E3S – LC/APC
Connector Connection to the FO-BD	E3S – LC/APC
Connector Whip length on FO-BD	approx. 100 cm connector stepped
Connector Inseration Loss	≥ 0.12dB Ø - ≤ 0.25dB Max. (Grade B)
Connector Return Loss	≥ 60 dB (Grade B)

E3S Connect® (FO-SC) subscriber connection, flush-mounting, 2xF, LC/APC QD, FO-BD

NEW



3D animation

· Scope of delivery: FO subscriber connection, LC-APC coupling and pre-assembled E3S Connect® fibre optic cable

Cable length	i info	Art.-No.	Inner packaging/shipping
10 m	-	4250029	- / 10
15 m	-	4250030	- / 10
20 m	-	4250031	- / 10
25 m	-	4250032	- / 10
30 m	-	4250033	- / 10
35 m	-	4250067	- / 10
40 m	-	4250068	- / 10
45 m	1	4250069	- / 10
70 m	1	4250070	- / 10
55 m	1	4250071	- / 10
60 m	1	4250072	- / 10
65 m	1	4250073	- / 10
70 m	1	4250074	- / 10
75 m	1	4250075	- / 10
80 m	1	4250076	- / 10
85 m	1	4250077	- / 10
90 m	1	4250078	- / 10
95 m	1	4250079	- / 10
100 m	1	4250080	- / 10

1) Product available on request.

Number of fibers	2
Certificate	GHMT Channel Link (z7479a-22 ; c7479a-22)
Installation type	Flush-mounting
Protection class	IP20
Impact resistance	IK07
Halogen-free	Yes
Cable routing	Backside (drum)
Coupler LC/APC Duplex	with flange, SC Simplex footprint
Coupler Amount	1
Fibre optic line Fibre optic class	Single Mode OS2 (G.657.A2)
Fibre optic line Fibre optic color coding	2-fibres: 1=red, 2=green
Fibre optic line ConstructionVo	B2ca according to EN50575:2014 + A1:2016
Fibre optic line Cable Ø	2,00 x 2,40 mm
Fibre optic line Traction	250 N (Installation), 100 N (Permanent)
Connector Connection to the FO-SC	E3S – LC/APC
Connector Connection to the FO-BD	E3S – LC/APC
Connector Whip length on FO-BD	approx. 100 cm connector stepped
Connector Inseration Loss	≥ 0.12dB Ø - ≤ 0.25dB Max. (Grade B)
Connector Return Loss	≥ 60 dB (Grade B)

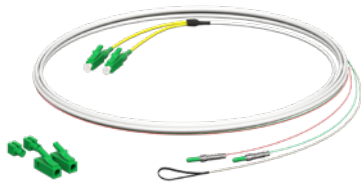

NEW

E3S Connect® fibre-optic patch cable

The E3S patch cable forms the connection line between the house transfer point (HTP) and the fibre-optic building distributor in network level 4, for example in apartment buildings.

- E3S patch cable is available in 2m and 3m lengths
- Available as 2x fibre variant
- High-quality fibre-optic cable G.657.A2
- E3S LC/APC connector for connection to the FO building distributor
- Standard LC / APC connector for easy connection directly to the house transfer point

E3S Connect® LC/APC-E3S fibre-optic patch cable, 2xF

NEW



Cable length	2 m	3 m
Number of fibers	2	2
Certificate	GHMT Channel Link (z7479a-22 ; c7479a-22)	GHMT Channel Link (z7479a-22 ; c7479a-22)
Fibre optic line Fibre optic class	Single Mode OS2 (G.657.A2)	Single Mode OS2 (G.657.A2)
Fibre optic line Fibre optic color coding	2-fibres: 1=red, 2=green	2-fibres: 1=red, 2=green
Fibre optic line Cable Ø	1,80 x 3,40 mm	1,80 x 3,40 mm
Fibre optic line Traction	250 N (Installation), 100 N (Permanent)	250 N (Installation), 100 N (Permanent)
Connector Connection to the FO-SC	Standard LC/APC	Standard LC/APC
Connector Connection to the FO-BD	E3S – LC/APC	E3S – LC/APC
Connector Whip length on FO-BD	approx. 100 cm connector stepped	approx. 100 cm connector stepped
Connector Insertion Loss	≥ 0.12dB Ø - ≤ 0.25dB Max. (Grade B)	≥ 0.12dB Ø - ≤ 0.25dB Max. (Grade B)
Connector Return Loss	≥ 60 dB (Grade B)	≥ 60 dB (Grade B)
Art.-No.	4264001	4264002
Inner packaging/shipping	- / 1	- / 1

E3S Connect® building distributor

The innovative product design of the E3S Connect® building distributor is suitable for use with E3S Connect system cables to set up a fibre-based building infrastructure. The installation-friendly product design allows simple, fast and therefore time-saving assembly. The E3S Connect® system is based on purely pluggable components; splicing work is not necessary with this system!

- Flexibility for managing fibre-based building networks
- Plug & Play installation
- Flexibility for the in-house concept



NEW

Cable / conduit inlet

Suitable for max. 32 x E3S Connect® patch cables

E3S Connect® patch cassettes

Suitable for max. 8 x patch cassettes

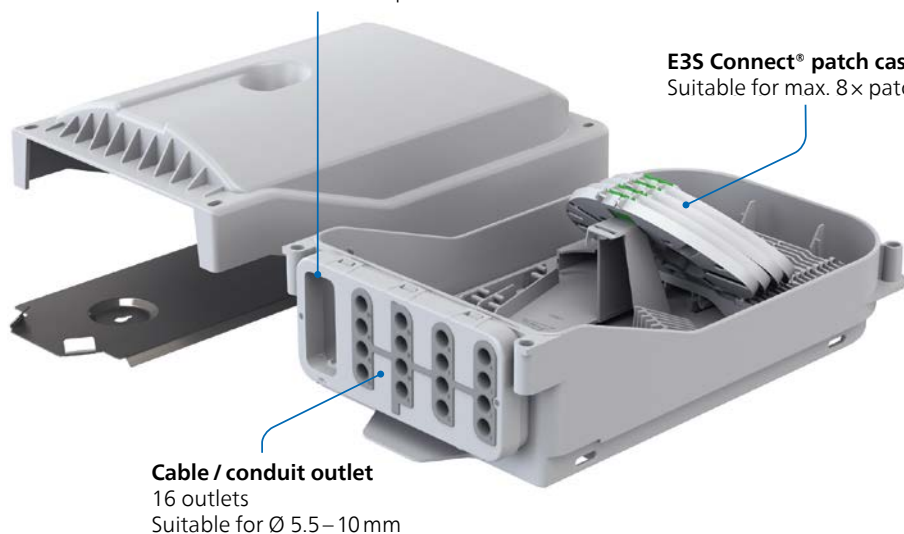

Cable / conduit outlet

16 outlets
Suitable for Ø 5.5 – 10 mm

E3S Connect® building distributor

NEW

- Scope of delivery: building distributor including 4x patch cassettes, 4x mounting screws, sealing material, moisture absorber



Length x Width x Height	380 x 220 x 130 mm
Certificate	GHMT Channel Link (z7479a-22 ; c7479a-22)
Installation type	Surface mount
Protection class	IP65 (surface mounting)
Number of fibers	16
Patch cassettes amount	4
Patch cassette assembly max.	8
Connector quantity	4
Connector version	LC/APC Quad
Colour	grey - RAL 7035
Halogen-free	Yes
Loop length (patch cassette)	250 mm
Bending radius (patch cassette)	30 mm
Connector holder	SC DX / LC QD
Entry cable/duct	2
Cable/duct entry Ø	4,5 - 8,3 mm
Cable/duct output quantity	16
Cable/duct output Ø	5,5 - 10 mm
Art.-No.	4240001
Inner packaging/shipping	- / 1

Note

The E3S Connect® building distributor is only compatible with KAISER E3S Connect® subscriber connections, patch and system cables. Subject to modifications



NEW

E3S Connect® patch cassette

The innovative patch cassette is specially designed for the E3S Connect® building distributor and can accommodate 1x LC/APC QD connector. The patch cassette upgrades the building distributor to accommodate the E3S Connect® cables in order to set up a purely pluggable fibre-optic-based building network.

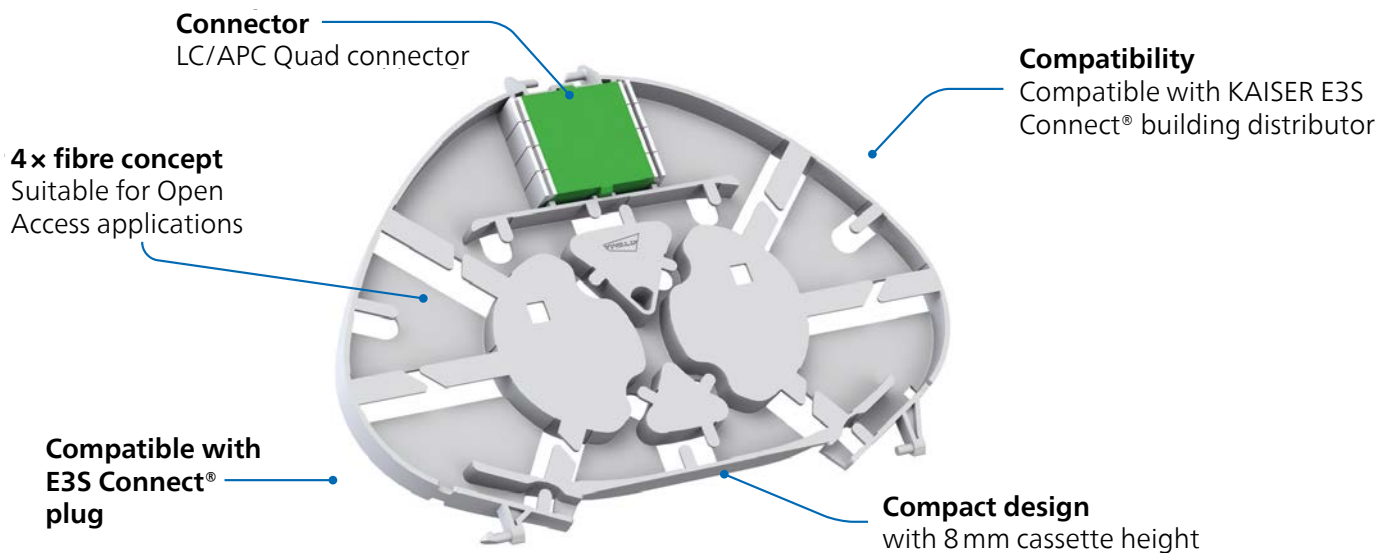

E3S Connect® patch cassette

· Scope of delivery: 4x patch cassettes, 4x LC/APC QD



NEW



Length x Width x Height	150 x 110 x 8 mm
Certificate	GHMT Channel Link (z7479a-22 ; c7479a-22)
Type	Patch
Patch cassettes amount	4
Patch cassettes height	8 mm
Loop length (patch cassette)	300 mm
Bending radius (patch cassette)	30 mm
Mounting options	On cassette holder
Connector version	LC/APC Quad
Colour	grey - RAL 7035
Halogen-free	Yes
Art.-No.	4264013
Inner packaging/shipping	- / 20

E3S Connect® system cable

The E3S system cable forms the connection line between the FO building distributor and the FO floor distributor in network level 4, for example in apartment buildings.

- E3S system cable available in 5x lengths (10m, 15m, 20m, 25m and 30m) – further lengths available on request
- Available with 2 or 4 fibres
- High-quality fibre-optic cable G.657.A2 and BauPVo B2ca
- Retractable and blowable cable
- Fibreglass cable is supplied in a handy unroll box



E3S Connect® E3S-E3S system cable, 4x fibres

NEW



· pre-assembled E3S Connect® fibre-optic cable

Cable length	Connector Return Loss	Art.-No.	Inner packaging/shipping
10 m	≥ 60 dB (Grade B)	4264008	- / 10
15 m	≥ 60 dB (Grade B)	4264009	- / 10
20 m	≥ 60 dB (Grade B)	4264010	- / 10
25 m	≥ 60 dB (Grade B)	4264011	- / 10
30 m	≥ 70 dB (Grade B)	4264012	- / 10

Number of fibers	4
Certificate	GHMT Channel Link (z7479a-22 ; c7479a-22)
Fibre optic line Fibre optic class	Single Mode OS2 (G.657.A2)
Fibre optic line Fibre optic color coding	4-fibres: 1=red, 2=green, 3=blue, 4=yellow
Fibre optic line ConstructionVo	B2ca according to EN50575:2014 + A1:2016
Fibre optic line Cable Ø	2,00 x 2,40 mm
Fibre optic line Traction	250 N (Installation), 100 N (Permanent)
Connector Connection to the FO-SC	Standard LC/APC
Connector Connection to the FO-BD	E3S – LC/APC
Connector Whip length on FO-BD	approx. 100 cm connector stepped
Connector Insertion Loss	≥ 0.12dB Ø - ≤ 0.25dB Max. (Grade B)

E3S Connect® E3S-E3S system cable, 2x fibres

NEW



· pre-assembled E3S Connect® fibre-optic cable

Cable length	Art.-No.	Inner packaging/shipping
10 m	4264003	- / 10
15 m	4264004	- / 10
20 m	4264005	- / 10
25 m	4264006	- / 10
30 m	4264007	- / 10

Number of fibers	2
Certificate	GHMT Channel Link (z7479a-22 ; c7479a-22)
Fibre optic line Fibre optic class	Single Mode OS2 (G.657.A2)
Fibre optic line Fibre optic color coding	2-fibres: 1=red, 2=green
Fibre optic line ConstructionVo	B2ca according to EN50575:2014 + A1:2016
Fibre optic line Cable Ø	2,00 x 2,40 mm
Fibre optic line Traction	250 N (Installation), 100 N (Permanent)
Connector Connection to the FO-SC	Standard LC/APC
Connector Connection to the FO-BD	E3S – LC/APC
Connector Whip length on FO-BD	approx. 100 cm connector stepped
Connector Insertion Loss	≥ 0.12dB Ø - ≤ 0.25dB Max. (Grade B)
Connector Return Loss	≥ 60 dB (Grade B)



NEW

E3S Connect® accessory box

The E3S Connect® accessory box is a comprehensive collection of tools, spare parts and cleaning equipment, specially developed for electricians and electrical installers working with the E3S Connect® system. This box offers a range of products to help you do your work more efficiently and reliably.

- E3S plug accessories
- Glass fibre cleaning tool
- Glass fibre tool
- Optical termination outlets
- LC/ DX connectors
- Can be combined with Sortimo and BS systems



E3S Connect® accessory box

NEW



- E3S Connect® accessory box equipped with:
- Cleaning tool: click cleaner for cleaning LC fibre optic connectors plugged into the connector, microfibre cleaning cassette for various fibre optic connectors, lint-free cleaning cloths for fibre cleaning
- Tools: screwdriver, Kevlar scissors, stripping tool
- Optical termination outlets: optical termination outlet flush-mounting (Art. No. 4252001), optical termination outlet flush-mounting (Art. No. 4250001)
- E3S Connect® spare parts: 25 x E3S Connect® housing, 25 x E3S Connect® locking element, 25 x E3S Connect® dust cap, 1 x LC/APC Quad connector, 2 x LC/APC Duplex connector



Depth x Width x Height	358 x 445 x 118 mm
Material case	Acrylonitrile butadiene styrene
Material lid	Polycarbonate
Own weight	2,5 {kg}
Loading capacity	25 {kg}
Art.-No.	4261011
Inner packaging/shipping	- / 1

E3S® Connect connector installation overview

1 After routing, simply plug the connectors together without tools.

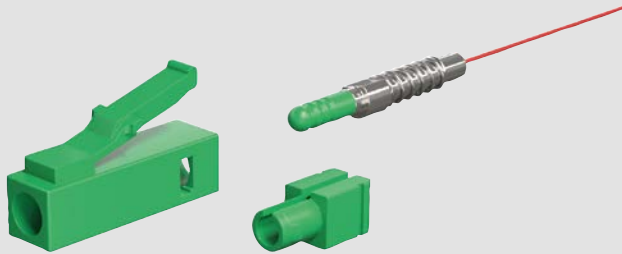

2 Push the connector with the orientation surfaces towards the locking housing. The connector end must be flush with the housing.

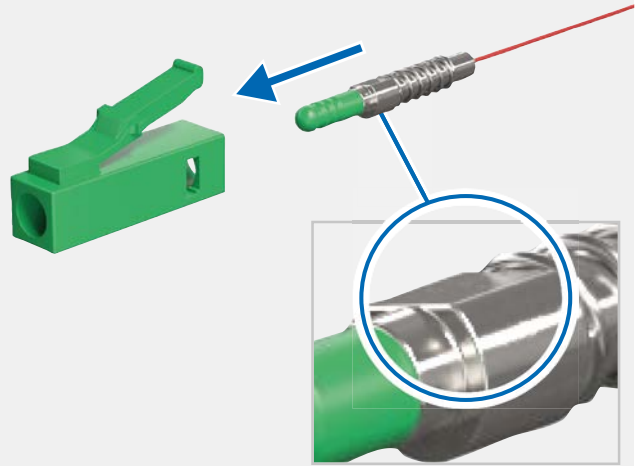

3 Slide the locking housing with the slot over the cable ...

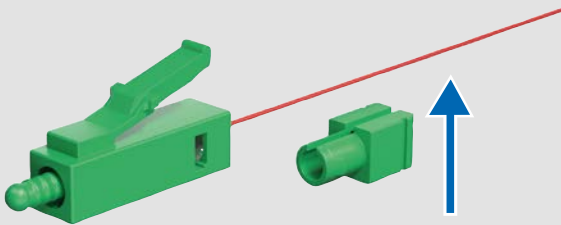

4 ... and press it forwards against the LC housing ...

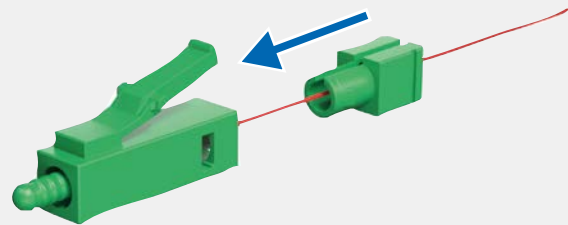

5 ...until the two side hooks snap into the openings.

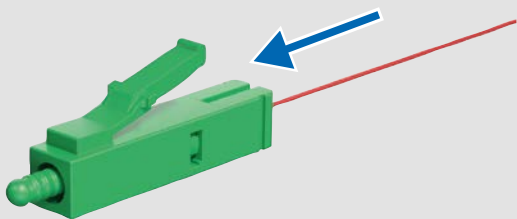

6 Note: The locking housing can only be pushed into the LC housing when the slot is facing upwards.



Building network – network level 4 (NE4)

Fibre-optic in-house cabling is understood to mean the comprehensive and complete building cabling from the fibre-optic termination point (FO-TP / BTP) to the fibre-optic subscriber connection (FO-TP) within the residential unit.

A distinction is also made within the building between secondary and tertiary cabling.

The secondary area comprises the cabling between the floors of a building. Cabling is also referred to as riser area cabling or building cabling. The secondary area comprises the cables from the FO-BD (fibre-optic building distributor) to the FO-FD (fibre-optic floor distributor).

The tertiary area is the horizontal floor cabling, the cabling within a floor of a building, and includes the cabling from the FO-FD (fibre-optic floor distributor) to the FO-SC (fibre-optic subscriber connection).

Examples

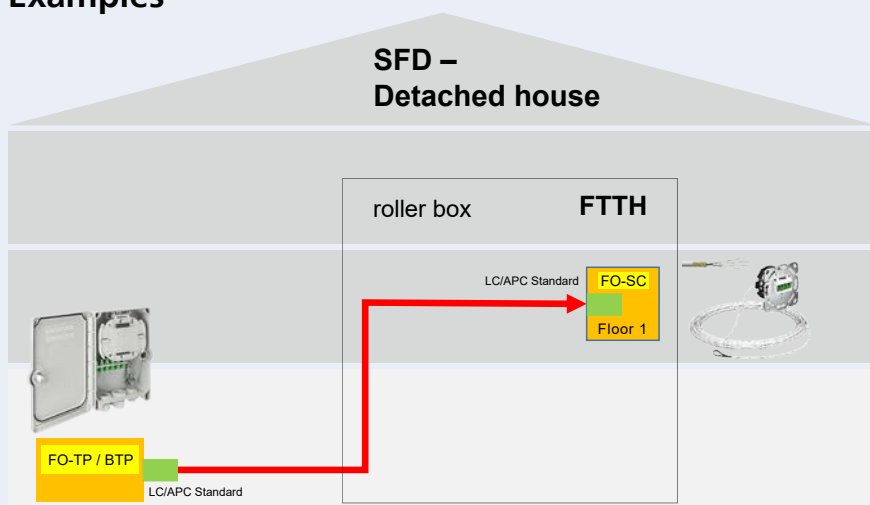





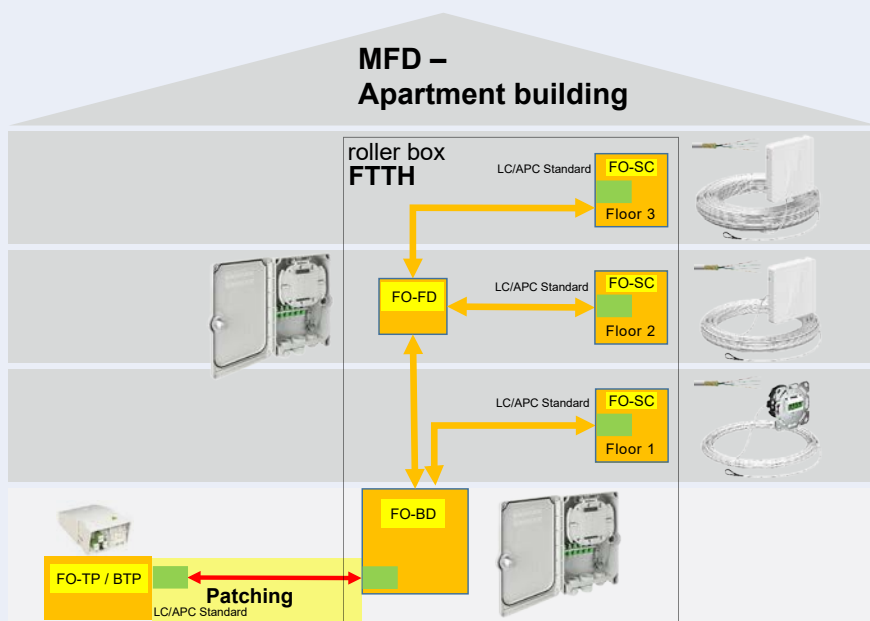

Connection to the FO-TP (Building transition point / BTP / FO-TP)





The subscriber cable is connected to the fibre optic termination point (FO-TP / BTP) via standard LC/APC connectors and is laid from the unit into the basement. There, the fibres are spliced onto a pigtail and connected to the LC/APC couplings.



Connection to the FO-BD (Fibre-optic building distributor)

The **fibre optic termination point** (FO-TP / BTP) is connected to a building distributor using a standard LC/APC patch cable. The cable for the subscriber connection is laid from the unit into the basement and spliced to a pigtail, then connected to the fibre optic building distributor (FO-BD) with LC/APC standard. It is possible to use another building distributor as a floor distributor.

Fibre-optic subscriber connection (FO-SC)					
					
	pg. 344	pg. 346	pg. 349	pg. 352	pg. 354
Art. No.	4252001 ... 05	4250001 4250002	4252006 ... 12 4252020 ... 26	4252013 ... 19 4252027 ... 33	4250005 ... 18
Network level	4	4	4	4	4
Type of installation	Surface-mounting	Flush-mounting	Surface-mounting	Surface-mounting	Flush-mounting
Cable routing	-	-	Rear side	Underside	Rear side
Protection class	IP 20	IP 20	IP 20	IP 20	IP 20
Number of fibres	1 – 4	1 – 4	2 / 4	2 / 4	2 / 4
Cable length	-	-	10 – 70 m	10 – 70 m	10 – 70 m
Splice protector holder	CSP crimp / mini heat shrink tubing	CSS	-	-	-
Number of splice cassettes	1	1	1	1	1
Loop length (splice cassette)	250 mm	150 mm	180 mm	180 mm	180 mm

Compact building distributor (FO-BD)			
			
	pg. 357 AT29231	pg. 357 AT29235	pg. 357 AT29236
Art. No.	AT29231	AT29235	AT29236
Network level	4	4	4
Connector version	LC / APC QD	LC / APC QD	LC / APC QD
Number of connectors	1	5	6
Type of installation	Surface-mounting	Surface-mounting	Surface-mounting
Protection class	IP 55	IP 55	IP 55
Number of fibres	4	20	24
Number of splice cassettes	1	1	1
Loop length (splice cassette)	250 mm	250 mm	250 mm

Further building distributors and product information can be found in the KAISER Connectivity main catalogue

KAISER offers a new and innovative product range for every application. With our comprehensive range, you also have the option of carrying out the complete in-house cabling as a spliceable variant or quite simply with our innovative E3S Connect® range as pluggable cabling.



Splicing



E3S Connect®
(pluggable)

Whether **splicing or plugging**, all products can be easily identified by our picture identification and selected to fit exactly.



Optical termination outlet (OTO), surface-mounted

The optical termination outlet will be the termination point of the optical fiber cable within the appartement / home. At this stage the connection to the optical network termination will be realized via an optical patch cable, as well as to the further individual network connections via WLAN/LAN for example.

- Compact fibre-optic subscriber connection
- unequipped, partial equipped and splice ready availabel
- Overlength management
- Suitable for CSP (Crimp-Splice protection)
- Integrated strain relief

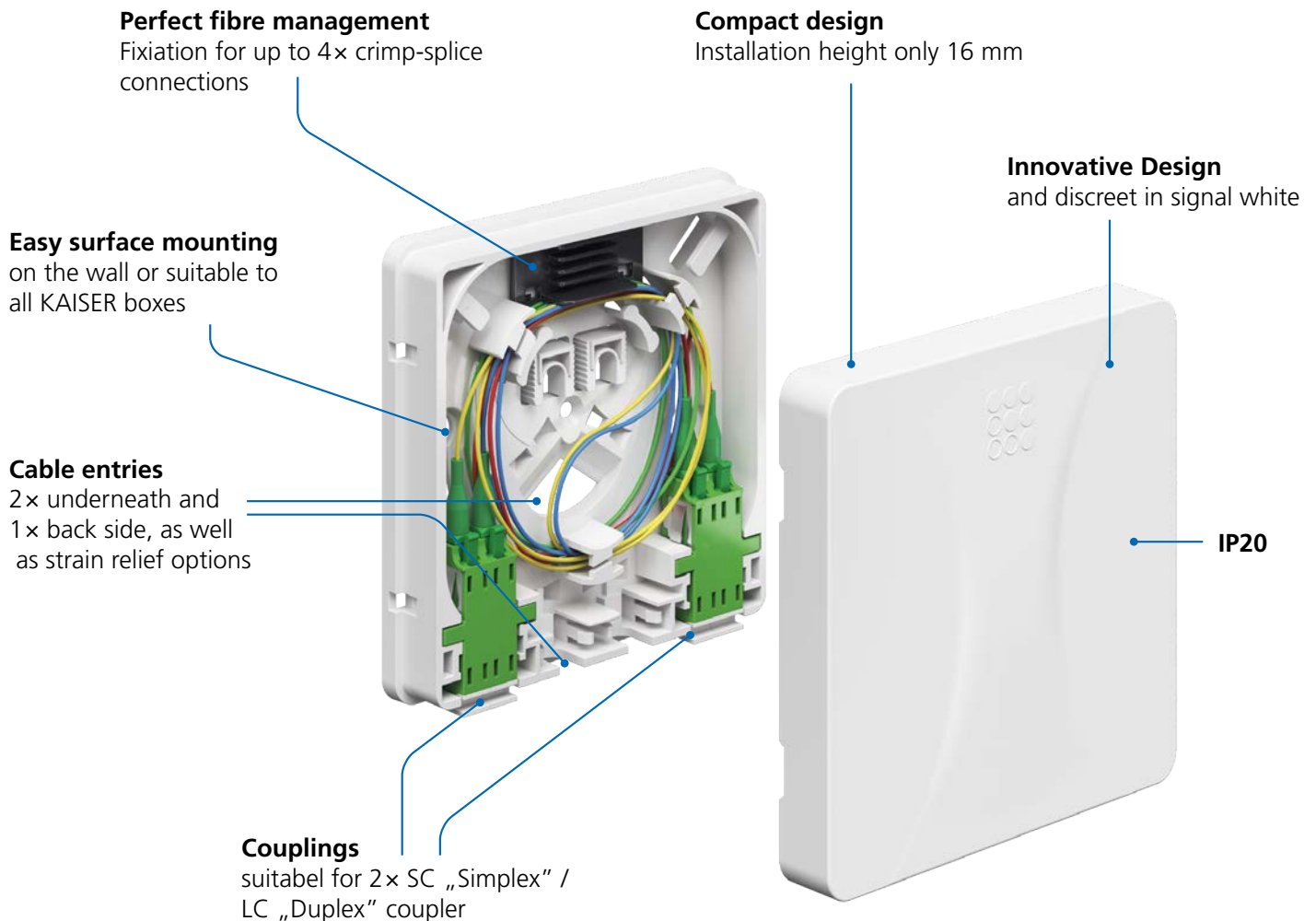



Montage



Create 5 mm drill holes.



Optionally, attach it to the KAISER installation box using device screws.



Fasten the fiber optic cable and engage the strain relief.



Optionally, fix the fiber optic cable with rear cable entry.



Insert the coupling in the desired position.



Insert, guide and put pigtails in place.



Lead fiber optic cable.



Perform splicing work and place the crimp splice protector in the holder.



Snap the housing cover into place.

Subject to modifications

FLUSH-MOUNTING
CAVITY WALL
CONCRETE
HOUSINGS
FIRE PROTECTION
PLUGGABLE
CONNECTIVITY
CABLE GLANDS
TOOLS
SERVICE

Optical termination outlet (OTO), surface-mounted

Optical termination outlet (OTO), unequipped

· OTO



3D animation

Length x Width x Height	85 x 85 x 16 mm
Installation type	Surface mount
Protection class	IP20
Impact resistance	IK07
Number of fibers	1 - 4
Halogen-free	Yes
Splice protection holder	CSP Crimp / Mini heat shrink tubing
Cabel entry Ø	2,3 - 5,3 mm
Colour	Signal white (RAL 9003)
Art.-No.	4252001
Inner packaging/shipping	- / 50

Optical termination outlet (OTO), partial equipped

· Scope of delivery: OTO,
1x LC/APC DX coupler



3D animation

Length x Width x Height	85 x 85 x 16 mm	85 x 85 x 16 mm
Installation type	Surface mount	Surface mount
Protection class	IP20	IP20
Impact resistance	IK07	IK07
Number of fibers	1 - 4	1 - 4
Halogen-free	Yes	Yes
Splice protection holder	CSP Crimp / Mini heat shrink tubing	CSP Crimp / Mini heat shrink tubing
Cabel entry Ø	2,3 - 5,3 mm	2,3 - 5,3 mm
Colour	Signal white (RAL 9003)	Signal white (RAL 9003)
Coupler LC/APC Duplex	with flange, SC Simplex footprint	with flange, SC Simplex footprint
Coupler Amount	1	2
Art.-No.	4252002	4252004
Inner packaging/shipping	- / 50	- / 50

Optical termination outlet (OTO), splice ready

· Scope of delivery: OTO,
1x LC/APC DX coupler, 1x pigtail



3D animation

Length x Width x Height	85 x 85 x 16 mm	85 x 85 x 16 mm
Installation type	Surface mount	Surface mount
Protection class	IP20	IP20
Impact resistance	IK07	IK07
Number of fibers	1 - 4	1 - 4
Halogen-free	Yes	Yes
Splice protection holder	CSP Crimp / Mini heat shrink tubing	CSP Crimp / Mini heat shrink tubing
Cabel entry Ø	2,3 - 5,3 mm	2,3 - 5,3 mm
Colour	Signal white (RAL 9003)	Signal white (RAL 9003)
Pigtail LC/APC Plug connectors	8° angled polish	8° angled polish
Pigtail Amount	2	4
Pigtail Insertion Loss	≥ 0.12dB Ø - ≤ 0.25dB Max. (Grade B)	≥ 0.12dB Ø - ≤ 0.25dB Max. (Grade B)
Pigtail Return Loss	≥ 60 dB (Grade B)	≥ 60 dB (Grade B)
Pigtail Fiber optic class	Single Mode OS2 (G.657.A2)	Single Mode OS2 (G.657.A2)
Coupler LC/APC Duplex	with flange, SC Simplex footprint	with flange, SC Simplex footprint
Coupler Amount	1	2
Art.-No.	4252003	4252005
Inner packaging/shipping	- / 30	- / 30

Optical termination outlet (OTO), flush-mounting

The optical termination outlet will be the termination point of the optical fiber cable within the appartement / home. At this stage the connection to the optical network termination will be realized via an optical patch cable, as well as to the further individual network connections via WLAN/LAN for example.

- Installation in all KAISER one-gang junction boxes
- Partial equipped and splice ready available
- Overlength management
- Suitable for CSP (Crimp-Splice protection)
- Design-compatible with all common TAE covers



Robust support frame

made of die-cast aluminum. With breakable corners suitable for round desings

Harmonized design

for precisely fitting flush-mounted installation in all KAISER one-gang junction boxes

Perfect fiber management
thanks to a rotatable storage drum (max. 1.80 m) and up to 4x crimp splice connections

Installation depth of max. 32 mm
also enables mounting in existing installations

Design compatible
TAE cover, compatible with all common switch manufacturers

Available with LC „Quad” or SC „Duplex”
couplings for optimal strain relief through 17° angled output



Subject to modifications

Optical termination outlet (OTO), flush-mounting

Montage

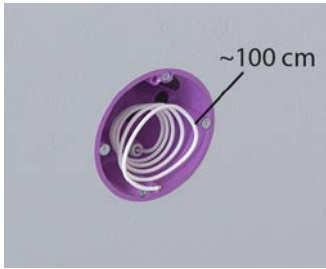

Prepare the fiber optic cable for connection.

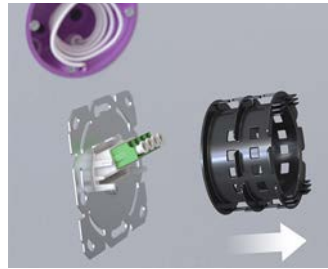

Pull off the fiber management drum.

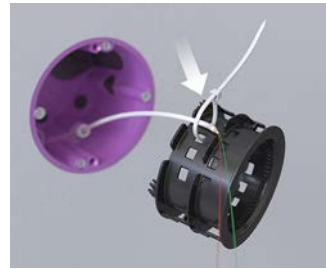

Fix the fiber optic cable to the fiber management drum.



Place glass fibers on the fiber management drum.

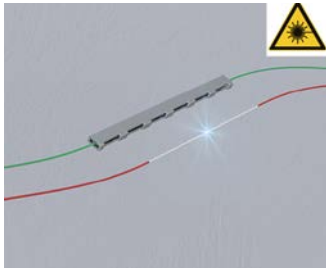

Perform splicing work.



Take off the crimp splice protector.

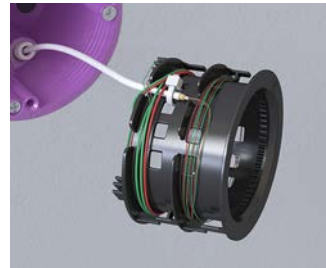

Place the pigtails on the fiber management drum.

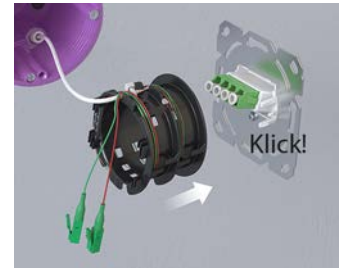

Latch the fiber management drum with the support ring.

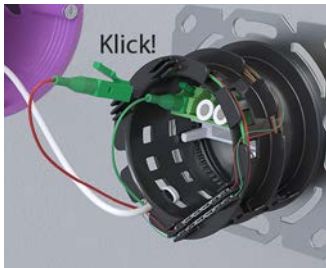

Insert the pigtails into the coupling.

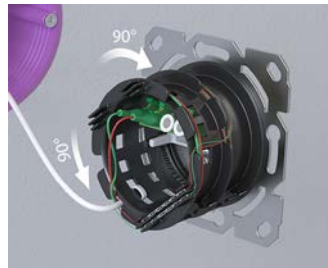

Optionally, adjust the fiber by turning.

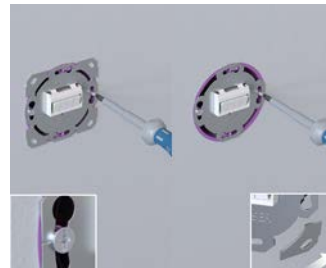

Assembly using device screws.



Attach the design cover.

Optical termination outlet (OTO), partial equipped

· Scope of delivery: OTO,
1x LC/APC QD coupler



3D animation

Installation type	Flush-mounting	Flush-mounting
Protection class	IP20	IP20
Impact resistance	IK07	IK07
Number of fibers	1 - 4	1 - 4
Halogen-free	Yes	Yes
Splice protection holder	CSP Crimp / Mini heat shrink tubing	CSP Crimp / Mini heat shrink tubing
Coupler Type	LC/APC Quad	SC/APC Duplex
Coupler Art	Without flange, SC Duplex footprint	Without flange, SC Duplex footprint
Coupler Amount	1	1
Art.-No.	4250001	4250002
Inner packaging/shipping	- / 10	- / 10

Optical termination outlet (OTO), surface-mounted with pre-assembled cable and cable entry from the backside

The optical termination outlet will be the termination point of the optical fibre cable within the appartement / home. Due to the pre-assembled cable in 7 different cable lengths, this variant forms an optimal solution for structured cabling in network level 4.

- Compact fibre-optic subscriber connection
- Dimensions: 85x85x16 mm (LxWxH)
- Colour similar to RAL9003 signal white
- Ready to splice with pre-assembled cable in 7x lengths (10m, 15m, 20m, 25m, 30m, 50m and 70m) - other lengths available on request
- Available with 2 or 4 fibres
- High-quality fibre-optic cable G.657.A2 and BauPVo B2ca
- Retractable and blowable cable
- Handy roll-off box with optimised installation aid

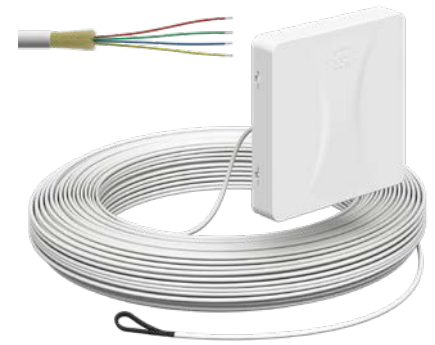

Available with 2x or 4x fibres

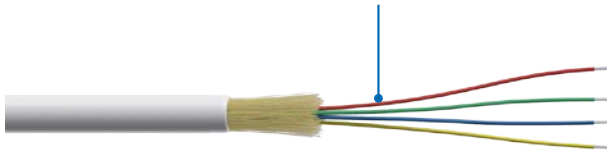

High quality fibre optic cable
G.657.A2 fibre and BauPVo B2ca
according to EN50575

Simple surface mounting
On the wall or suitable for all
KAISER built-in boxes

IP20

Convenient cable routing
Small cable diameter of approx. 3.0 mm, which means it
can be pulled in or blown in (from 7 mm micro tube)

Cable entry
2 versions available,
1 x bottom (wall mounting) and
1 x backside (wall mounting)

Optical termination outlet (OTO), surface-mounted

with pre-assembled cable and cable entry from the backside

Installation



Make 5 mm drill holes.



Optionally, fasten to the KAISER installation box using device screws or install it in a multimedia distributor.



One-gang box installed with micro duct.



Prepare the roll-off box for installation.



Connect the pull-in aid to the cable end and pull it into the empty duct.

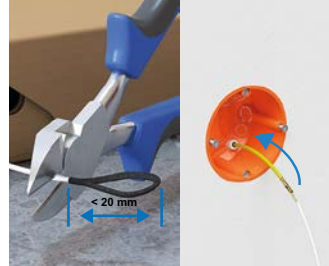

Optional: for micro ducts < 12mm, the loop must be cut off. Fixing without pull-in loop.



Roll-off box is brought into the correct unrolling position. Optionally, the footrest can be folded out for better handling.



At the end, remove the optical termination outlet from the cardboard box and pull in the remaining cable.



Now mount the optical termination outlet exactly on the device box, wall or multimedia panel.



Latch on on the cover and plug the patch cable in to the router (optional).



Example (left): Installation with cable from the underside. Example (right): Installation with cable from the rear.



Example: Installation in the multimedia distributor.



Optical termination outlet (OTO), surface-mounted with pre-assembled cable and cable entry from the backside

Optical termination outlet (OTO), ready to splice, 2x fibres, backside

· Scope of delivery: OTO, LC/APC coupling, connector and fibre optic cable



3D animation

Cable length	Art.-No.	Inner packaging/shipping
10 m	4252006	- / 1
15 m	4252007	- / 1
20 m	4252008	- / 1
25 m	4252009	- / 1
30 m	4252010	- / 1
50 m	4252011	- / 1
70 m	4252012	- / 1
Length x Width x Height	85 x 85 x 16 mm	
Cable routing	Backside	
Certificate	GHMT Channel Link (z7384b-22 ; c7384b-22)	
Installation type	Surface-mounted (on installation box) / multimedia distributor	
Protection class	IP20	
Impact resistance	IK07	
Halogen-free	Yes	
Splice protection holder	No	
Cabel entry Ø	2,3 - 5,3 mm	
Colour	Signal white (RAL 9003)	
Coupler LC/APC Duplex	with flange, SC Simplex footprint	
Coupler Amount	1	
Fibre optic line Fibre optic class	Single Mode OS2 (G.657.A2)	
Fibre optic line LC/APC simplex connectors	2x (Grade A)	
Fibre optic line Fibre optic color coding	1=red, 2=green	
Fibre optic line ConstructionVo	B2ca according to EN50575:2014 + A1:2016	
Fibre optic line Cable Ø	3,00 mm +/- 0,15 mm	
Fibre optic line Traction	450 N (max. fibre load 0.50%), 225 N (max. fibre load 0.25%)	

Optical termination outlet (OTO), ready to splice, 4x fibres, backside

· Scope of delivery: OTO, LC/APC coupling, connector and fibre optic cable



3D animation

Cable length	Art.-No.	Inner packaging/shipping
10 m	4252020	- / 1
15 m	4252021	- / 1
20 m	4252022	- / 1
25 m	4252023	- / 1
30 m	4252024	- / 1
50 m	4252025	- / 1
70 m	4252026	- / 1
Length x Width x Height	85 x 85 x 16 mm	
Number of fibers	4	
Cable routing	Backside	
Certificate	GHMT Channel Link (z7384b-22 ; c7384b-22)	
Installation type	Surface-mounted (on installation box) / multimedia distributor	
Protection class	IP20	
Impact resistance	IK07	
Halogen-free	Yes	
Splice protection holder	No	
Cabel entry Ø	2,3 - 5,3 mm	
Colour	Signal white (RAL 9003)	
Coupler LC/APC Duplex	with flange, SC Simplex footprint	
Coupler Amount	2	
Fibre optic line Fibre optic class	Single Mode OS2 (G.657.A2)	
Fibre optic line LC/APC simplex connectors	2x (Grade A)	
Fibre optic line Fibre optic color coding	1=red, 2=green, 3=blue, 4=yellow	
Fibre optic line ConstructionVo	B2ca according to EN50575:2014 + A1:2016	
Fibre optic line Cable Ø	3,00 mm +/- 0,15 mm	
Fibre optic line Traction	450 N (max. fibre load 0.50%), 225 N (max. fibre load 0.25%)	

Subject to modifications

FLUSH-MOUNTING
CAVITY WALL
CONCRETE
HOUSINGS
FIRE PROTECTION
PLUGGABLE
CONNECTIVITY
CABLE GLANDS
TOOLS
SERVICE

Optical termination outlet (OTO), surface-mounted

with pre-assembled cable and cable entry from the bottom

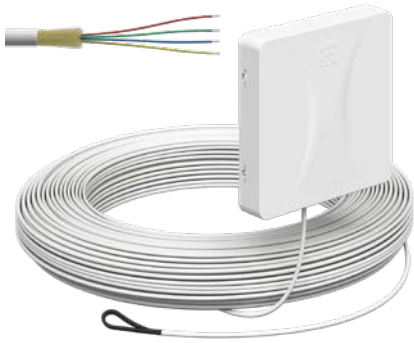

Optical termination outlet (OTO), surface-mounted with pre-assembled cable and cable entry from the bottom

The optical termination outlet will be the termination point of the optical fibre cable within the appartement / home. Due to the pre-assembled cable in 7 different cable lengths, this variant forms an optimal solution for structured cabling in network level 4.

- Compact fibre-optic subscriber connection
- Dimensions: 85x85x16 mm (LxWxH)
- Colour similar to RAL9003 signal white
- Ready to splice with pre-assembled cable in 7x lengths (10m, 15m, 20m, 25m, 30m, 50m and 70m) - other lengths available on request
- Available with 2 or 4 fibres
- High-quality fibre-optic cable G.657.A2 and BauPVo B2ca
- Retractable and blowable cable
- Handy roll-off box with optimised installation aid



Available with 2x or 4x fibres

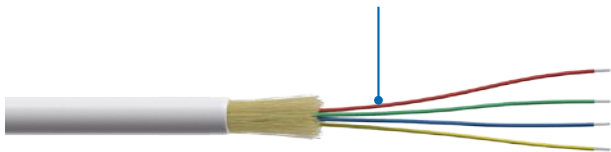

High quality fibre optic cable
G.657.A2 fibre and BauPVo B2ca according to EN50575

Simple surface mounting

On the wall or suitable for all KAISER built-in boxes

IP20

Convenient cable routing

Small cable diameter of approx. 3.0 mm, which means it can be pulled in or blown in (from 7 mm micro tube)

Cable entry

2 versions available,
1x bottom (wall mounting) and
1x backside (wall mounting)

Optical termination outlet (OTO), surface-mounted

with pre-assembled cable and cable entry from the bottom

Installation



Make 5 mm drill holes.



Optionally, fasten to the KAISER installation box using device screws or install it in a multimedia distributor.



One-gang box installed with micro duct.



Prepare the roll-off box for installation.



Connect the pull-in aid to the cable end and pull it into the empty duct.

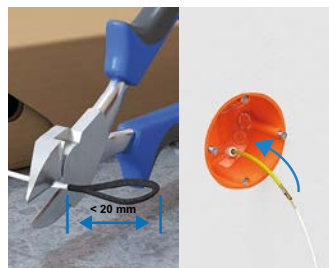

Optional: for micro ducts < 12mm, the loop must be cut off. Fixing without pull-in loop.

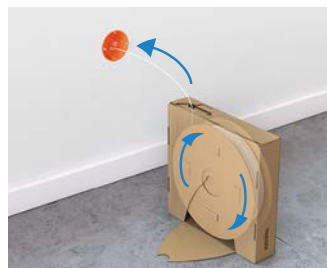

Roll-off box is brought into the correct unrolling position. Optionally, the footrest can be folded out for better handling.



At the end, remove the optical termination outlet from the cardboard box and pull in the remaining cable.



Now mount the optical termination outlet exactly on the device box, wall or multimedia panel.



Latch on on the cover and plug the patch cable in to the router (optional).



Example (left): Installation with cable from the underside. Example (right): Installation with cable from the rear.



Example: Installation in the multimedia distributor.



Optical termination outlet (OTO), surface-mounted

with pre-assembled cable and cable entry from the bottom

Optical termination outlet (OTO), ready to splice, 2x fibres, bottom

· Scope of delivery: OTO, LC/APC coupling, connector and fibre optic cable



3D animation

Cable length	Art.-No.	Inner packaging/shipping
10 m	4252013	- / 1
15 m	4252014	- / 1
20 m	4252015	- / 1
25 m	4252016	- / 1
30 m	4252017	- / 1
50 m	4252018	- / 1
70 m	4252019	- / 1

Length x Width x Height	85 x 85 x 16 mm
Number of fibers	2
Cable routing	Bottom
Certificate	GHMT Channel Link (z7384b-22 ; c7384b-22)
Installation type	Surface-mounted (on installation box) / multimedia distributor
Protection class	IP20
Impact resistance	IK07
Halogen-free	Yes
Splice protection holder	No
Cabel entry Ø	2,3 - 5,3 mm
Colour	Signal white (RAL 9003)
Coupler LC/APC Duplex	with flange, SC Simplex footprint
Coupler Amount	1
Fibre optic line Fibre optic class	Single Mode OS2 (G.657.A2)
Fibre optic line LC/APC simplex connectors	2x (Grade A)
Fibre optic line Fibre optic color coding	1=red, 2=green
Fibre optic line ConstructionVo	B2ca according to EN50575:2014 + A1:2016
Fibre optic line Cable Ø	3,00 mm +/- 0,15 mm
Fibre optic line Traction	450 N (max. fibre load 0.50%), 225 N (max. fibre load 0.25%)

Optical termination outlet (OTO), ready to splice, 4x fibres, bottom

· Scope of delivery: OTO, LC/APC coupling, connector and fibre optic cable



3D animation

Cable length	Art.-No.	Inner packaging/shipping
10 m	4252027	- / 1
15 m	4252028	- / 1
20 m	4252029	- / 1
25 m	4252030	- / 1
30 m	4252031	- / 1
50 m	4252032	- / 1
70 m	4252033	- / 1

Length x Width x Height	85 x 85 x 16 mm
Number of fibers	4
Cable routing	Bottom
Certificate	GHMT Channel Link (z7384b-22 ; c7384b-22)
Installation type	Surface-mounted (on installation box) / multimedia distributor
Protection class	IP20
Impact resistance	IK07
Halogen-free	Yes
Splice protection holder	No
Cabel entry Ø	2,3 - 5,3 mm
Colour	Signal white (RAL 9003)
Coupler LC/APC Duplex	with flange, SC Simplex footprint
Coupler Amount	2
Fibre optic line Fibre optic class	Single Mode OS2 (G.657.A2)
Fibre optic line LC/APC simplex connectors	2x (Grade A)
Fibre optic line Fibre optic color coding	1=red, 2=green, 3=blue, 4=yellow
Fibre optic line ConstructionVo	B2ca according to EN50575:2014 + A1:2016
Fibre optic line Cable Ø	3,00 mm +/- 0,15 mm
Fibre optic line Traction	450 N (max. fibre load 0.50%), 225 N (max. fibre load 0.25%)

Optical termination outlet (OTO), flush-mounted with pre-assembled cable from the backside

The optical termination outlet will be the termination point of the optical fibre cable within the appartement / home. Due to the pre-assembled cable in 7 different cable lengths, this variant forms an optimal solution for structured cabling in network level 4.

- Installation in all KAISER one-gang junction boxes
- Ready to splice with pre-assembled cable in 7x lengths (10m, 15m, 20m, 25m, 30m, 50m and 70m) - other lengths available on request
- Available with 2 or 4 fibres
- High-quality fibre-optic cable G.657.A2 and BauPVo B2ca
- Retractable and blowable cable
- Handy roll-off box with optimised installation aid
- Compatible with all common TAE design covers

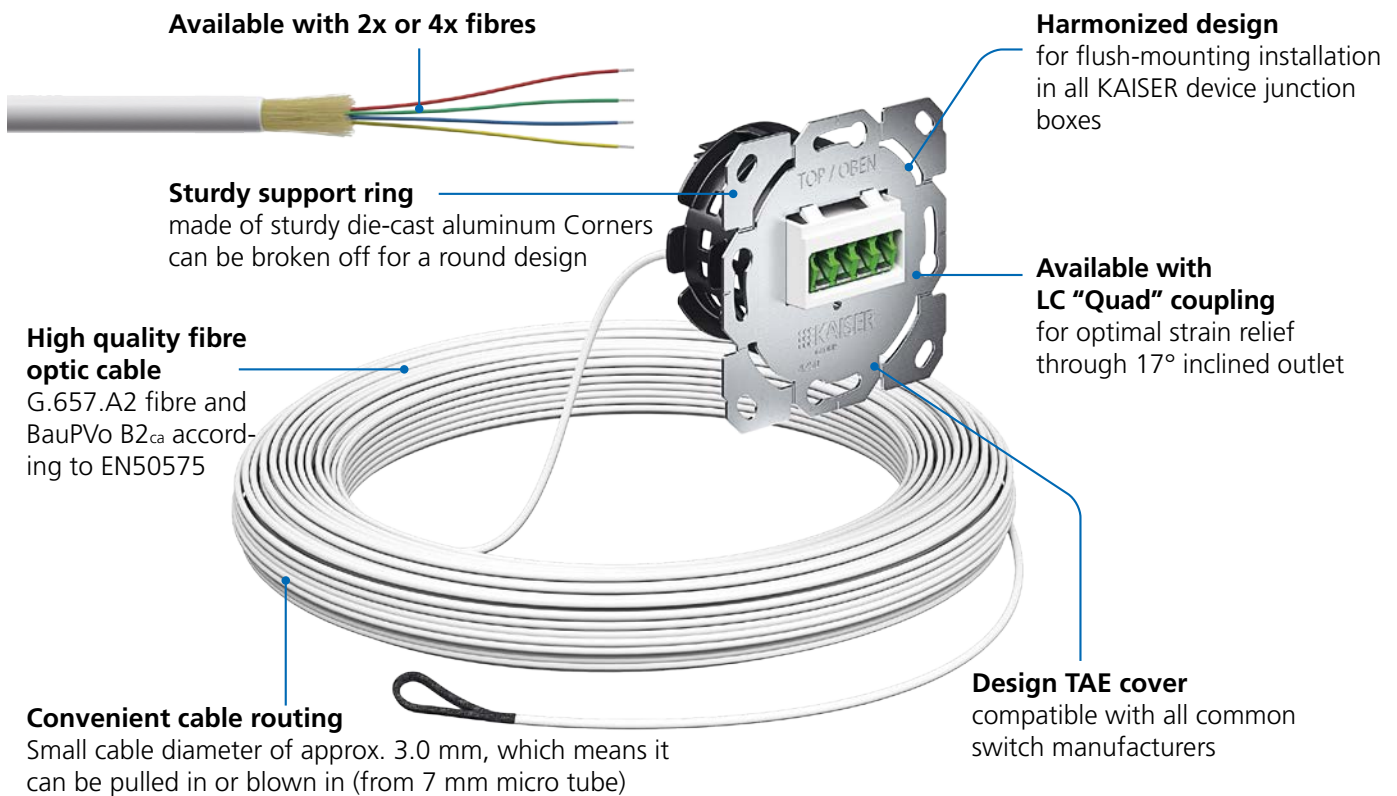

Optical termination outlet (OTO), flush-mounted

with pre-assembled cable from the backside

Installation



If necessary, detach the flush-mounted subscriber connection from the one-gang box or prepare it for installation.



Connect the pull-in aid to the cable end and pull it into the empty duct.

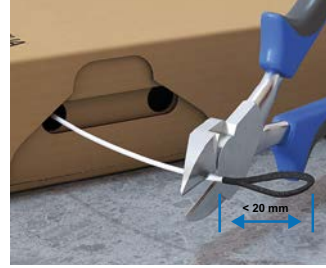

Optional: for micro ducts < 12mm, the loop must be cut off.



Fixing without pull-in loop.

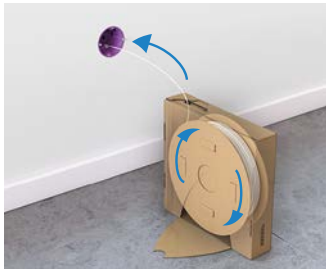

Roll-off box is brought into the correct unrolling position. Optionally, the footrest can be folded out for better handling.



At the end, remove the sub-scriber connection from the cardboard box and pull in the remaining cable.



Now fit the subscriber connection exactly in the device box.



Fit the TAE cover. Plug the patch cable into the router (optional).

Optical termination outlet (OTO), ready to splice, 2x fibres, backside

· Scope of delivery: OTO, LC/APC coupling, connector and fibre optic cable



3D animation

Cable length	Art.-No.	Inner packaging/shipping
10 m	4250005	- / 1
15 m	4250006	- / 1
20 m	4250007	- / 1
25 m	4250008	- / 1
30 m	4250009	- / 1
50 m	4250010	- / 1
70 m	4250011	- / 1

Number of fibers	2
Cable routing	Backside
Certificate	GHMT Channel Link (z7384b-22 ; c7384b-22)
Installation type	Flush-mounting
Protection class	IP20
Impact resistance	IK07
Halogen-free	Yes
Splice protection holder	CSP Crimp / Mini heat shrink tubing
Coupler Type	LC/APC Quad
Coupler Art	With flange, SC Duplex footprint
Coupler Amount	1
Fibre optic line Fibre optic class	Single Mode OS2 (G.657.A2)
Fibre optic line LC/APC simplex connectors	2x (Grade A)
Fibre optic line Fibre optic color coding	1=red, 2=green
Fibre optic line ConstructionVo	B2ca according to EN50575:2014 + A1:2016
Fibre optic line Cable Ø	3,00 mm +/- 0,15 mm
Fibre optic line Traction	450 N (max. fibre load 0.50%), 225 N (max. fibre load 0.25%)

Optical termination outlet (OTO), flush-mounted

with pre-assembled cable from the backside

Optical termination outlet (OTO), ready to splice, 4x fibres, backside

· Scope of delivery: OTO, LC/APC coupling, connector and fibre optic cable



3D animation

Cable length	Art.-No.	Inner packaging/shipping
10 m	4250012	- / 1
15 m	4250013	- / 1
20 m	4250014	- / 1
25 m	4250015	- / 1
30 m	4250016	- / 1
50 m	4250017	- / 1
70 m	4250018	- / 1

Number of fibers	4
Cable routing	Backside
Certificate	GHMT Channel Link (z7384b-22 ; c7384b-22)
Installation type	Flush-mounting
Protection class	IP20
Impact resistance	IK07
Halogen-free	Yes
Splice protection holder	CSP Crimp / Mini heat shrink tubing
Coupler Type	LC/APC Quad
Coupler Art	With flange, SC Duplex footprint
Coupler Amount	1
Fibre optic line Fibre optic class	Single Mode OS2 (G.657.A2)
Fibre optic line LC/APC simplex connectors	2x (Grade A)
Fibre optic line Fibre optic color coding	1=red, 2=green, 3=blue, 4=yellow
Fibre optic line ConstructionVo	B2ca according to EN50575:2014 + A1:2016
Fibre optic line Cable Ø	3,00 mm +/- 0,15 mm
Fibre optic line Traction	450 N (max. fibre load 0.50%), 225 N (max. fibre load 0.25%)

Simply handy. KAISER roller box.

The handy roller boxes for the pre-assembled subscriber connections offer a convenient packaging unit and are also an optimised installation aid in network level 4 cabling.

In addition, the round cardboard inlay facilitates easy, space-saving unrolling of the fibre-optic cable without having to remove the subscriber connection.

The compact dimensions of 266×256×54 mm (L×W×H) as well as the double-sided readable product label (front & cover side) offer advantages both for assembly and storage.

Handling

- Fold out the break-out opening for improved stability and rolling of the cable (footrest)
- Position the cardboard box upright and simply unroll the fibre-optic cable out of the pre-defined cable opening
- The inlay with the subscriber connection rotates to fit exactly in the cardboard box
- At the end, remove the subscriber connection and the cable from the coil box and assemble them

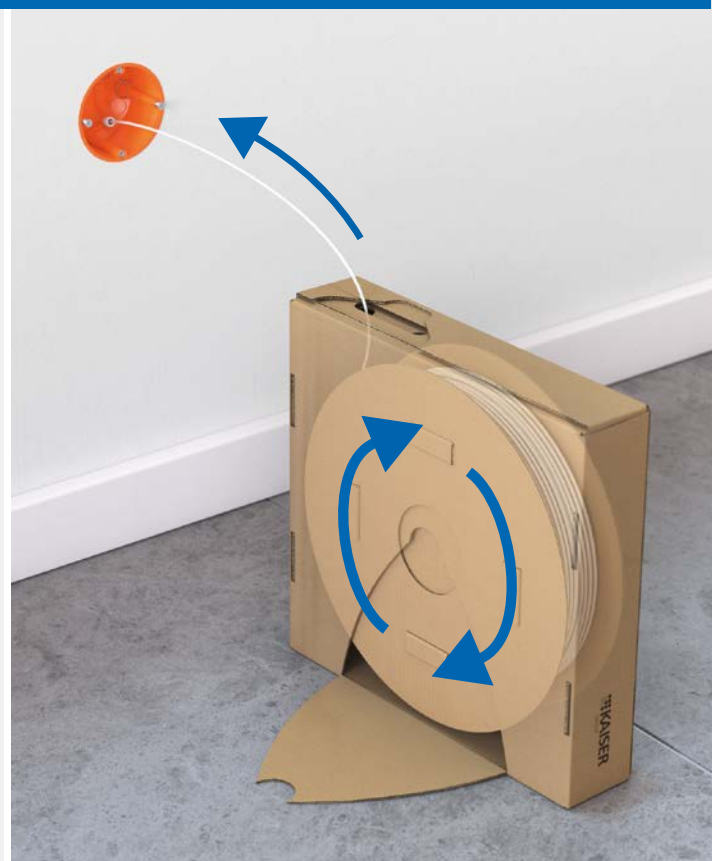

Subject to modifications



Compact building distributor (Gf-GV)

The compact building distributor by the the KAISER GROUP is designed for up to 24x fibres and can be delivered in different configuration levels. The compact building distributor can also be used as a house transfer point. Various versions of the compact building distributor have been approved by „atene KOM“ and are suitable for use in subsidised projects.

- Flexibility in the management of fibre optic networks
- Protected plug connection, internal fibre optic coupling
- Removable box cover
- Flexibility in the FTTX concept.
- Structured fibre optic management.

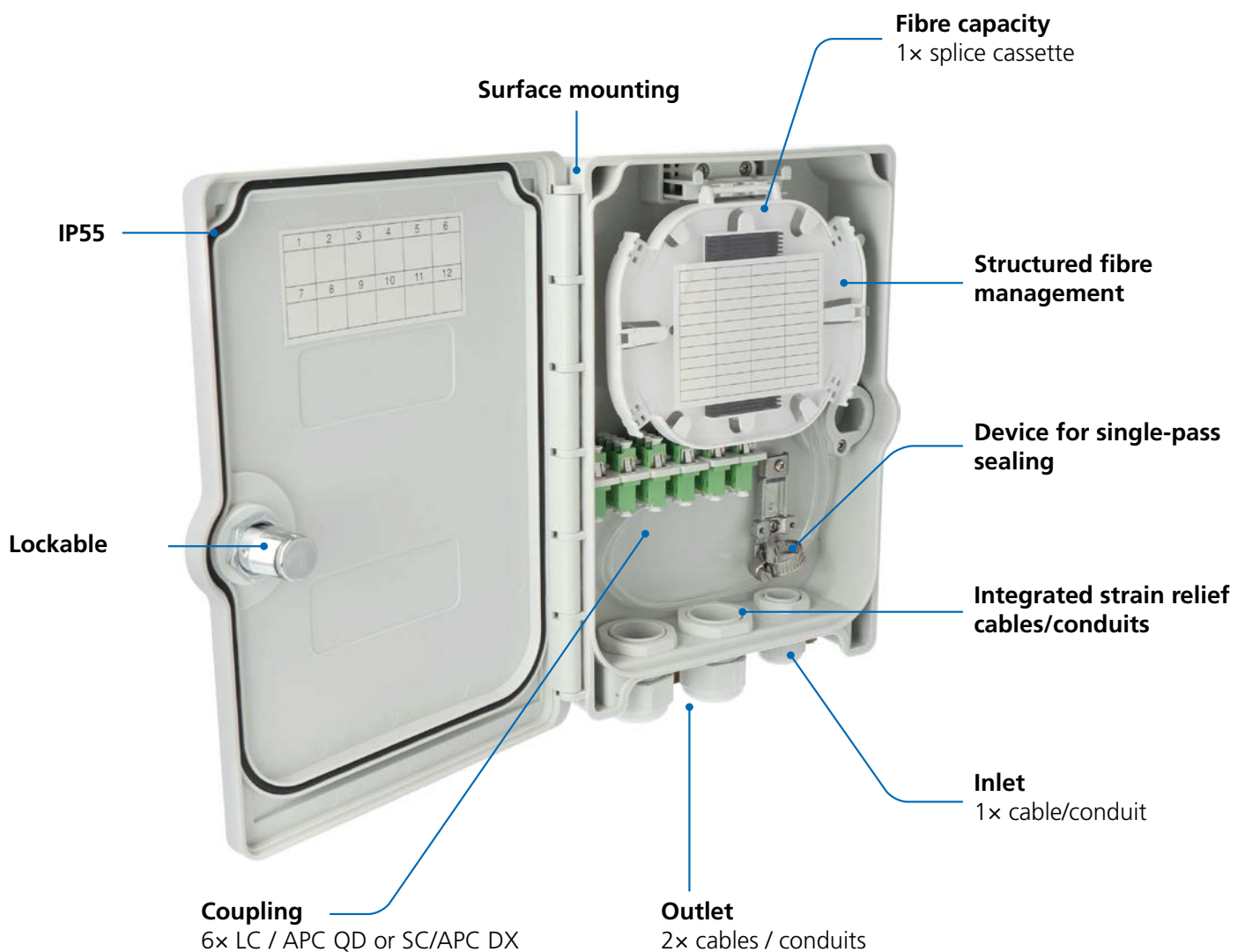

Notes

Mechanical protection of the fibre optic management and easy installation are guaranteed. In addition, the compact building distributor has 6x LC/Quad, 6x SC/DX coupling breakouts. These can be supplied without coupling, equipped or partially equipped. The couplings are located inside the housing to prevent unauthorised access. The compact building distributor is lockable. In addition, there is the possibility of sealing the compact building distributor to prevent unauthorised opening.

Compact building distributor (Gf-GV), CSP, partially equipped

· Scope of delivery: Compact Gf-GV, LC/ APC QD coupling



Length x Width x Height	258 x 186 x 61 mm	258 x 186 x 61 mm	258 x 186 x 61 mm
Installation type	Surface mount	Surface mount	Surface mount
Protection class	IP55 (surface mounting)	IP55 (surface mounting)	IP55 (surface mounting)
Number of fibers	4	20	24
Connector quantity	1	5	6
Connector version	LC / APC QD	LC / APC QD	LC / APC QD
Halogen-free	Yes	Yes	Yes
Splice protection holder	CSP Crimp / Mini heat shrink tubing	CSP Crimp / Mini heat shrink tubing	CSP Crimp / Mini heat shrink tubing
Entry cable/duct	1	1	1
Cable/duct entry Ø	max. 11,0 mm	max. 11,0 mm	max. 11,0 mm
Cable/duct output quantity	2	2	2
Cable/duct output Ø	max. 12 x 2 mm	max. 12 x 2 mm	max. 12 x 2 mm
Colour	Light grey - RAL 7035	Light grey - RAL 7035	Light grey - RAL 7035
Art.-No.	AT29231	AT29235	AT29236
Inner packaging/shipping	- / 10	- / 10	- / 10

FLUSH-MOUNTING

CAVITY WALL

CONCRETE

HOUSINGS

FIRE PROTECTION

PLUGGABLE

CONNECTIVITY

CABLE GLANDS

TOOLS

SERVICE



Syntec® Plastic

- Highest quality and practicality
- Perfectly coordinated range for everyday craft supplies



Syntec® Brass

- Robust and reliable – proven a million times over
- Professional cable entry for every application
- Perfectly coordinated range for everyday craft supplies



Synthetic cable glands Progress® GRP for multiple cables

- Outstanding compression technology
- Multiple sealing inserts
- IP 68 protection class
- Extensive basic programme



Accessories for Syntec®



- Accessories for plastic and brass cable glands



MontaX

- Mounting plate for fixing devices and components
- Well over 200 attachment possibilities

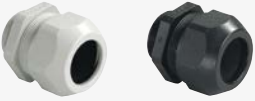
Cable glands Syntec® with lamellar technology

	Entry thread		
	metric short	metric long	
Plastic one-piece sealing ring 	pg. 361	pg. 362	
Plastic with anti-kink protection One-piece sealing ring 	pg. 363	see AGRO cable glands catalogue	
Brass one-piece sealing ring 	pg. 365	pg. 365	

Cable glands Progress® with compression technology

	Entry thread		
	metric		
Plastic GRP one-piece sealing insert 	pg. 366		

Accessories for Syntec® cable glands

	Counternuts	Locking plugs	
Synthetic material 	pg. 367	pg. 368	
Brass 	pg. 369	pg. 369	

FLUSH-MOUNTING

CAVITY WALL

CONCRETE

HOUSINGS

FIRE PROTECTION

PLUGGABLE

CONNECTIVITY

CABLE GLANDS

TOOLS

SERVICE



SYNTEC® synthetic cable gland

SYNTEC® synthetic cable gland with innovative lamellar technology including movable jointed lamellae and compression nuts for everyday use (cannot be overtightened).

- Made from high-quality, weather-resistant polyamide
- With short and long metric entry thread
- Standard/reducing sealing rings
- With environmentally resistant TPE sealing ring
- High level of strain relief and simultaneous distortion protection
- In two colours (light grey, black) from stock, other colours on request
- Good chemical resistance
- Protection class IP 68, waterproof
- Tested acc. to EN 62444

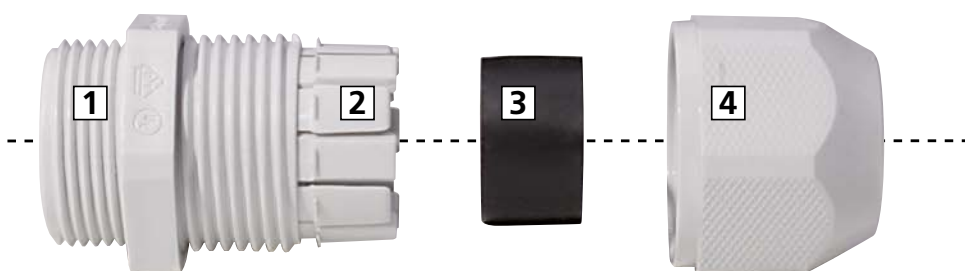

1 Lower part | 2 Lamellar | 3 Sealing ring | 4 Push-down nut

The nut's large-area hexagon always provides a safe and firm grip when turned by hand and tightened with the tool.



Short entry thread metric

Material: Polyamide PA 6
 Properties: halogen-free, black UV resistant (tested according to EN ISO 4892-2)
 Sealing ring: TPE or CR (Neoprene)
 Strain relief: Version A acc. to EN 62444
 Protection class: IP 68
 NEMA Type rating: 4X
 Operation temperature: -30 °C / +100 °C



Light grey RAL 7035
 One-piece sealing ring

G	$\begin{matrix} > \varnothing < \\ \text{min mm} \end{matrix}$	$\begin{matrix} > \varnothing < \\ \text{max mm} \end{matrix}$	$\begin{matrix} \varnothing \\ \text{mm} \end{matrix}$	H mm	L mm	Art.-No.	
M12x1.5	2.5	6.5	15	21	6	1555.12.06	100
M16x1.5	2.0	6.0	19	25	8	1555.17.06	50
M16x1.5	5.0	10.0	19	25	8	1555.17.10	50
M20x1.5	3.5	8.0	24	29	9	1555.20.08	50
M20x1.5	7.0	13.0	24	29	9	1555.20.13	50
M25x1.5	5.0	11.0	29	38	10	1555.25.11	25
M25x1.5	10.0	17.0	29	38	10	1555.25.17	25
M32x1.5	17.0	25.0	42	36	10	1555.32.25	20

Available on request:

Dark grey RAL 7001



SYNTEC



Black RAL 9005
 One-piece sealing ring

G	$\begin{matrix} > \varnothing < \\ \text{min mm} \end{matrix}$	$\begin{matrix} > \varnothing < \\ \text{max mm} \end{matrix}$	$\begin{matrix} \varnothing \\ \text{mm} \end{matrix}$	H mm	L mm	Art.-No.	
M12x1.5	2.5	6.5	15	21	6	1545.12.06	100
M16x1.5	2.0	6.0	19	25	8	1545.17.06	50
M16x1.5	5.0	10.0	19	25	8	1545.17.10	50
M20x1.5	3.5	8.0	24	29	9	1545.20.08	50
M20x1.5	7.0	13.0	24	29	9	1545.20.13	50
M25x1.5	5.0	11.0	29	38	10	1545.25.11	25
M25x1.5	10.0	17.0	29	38	10	1545.25.17	25
M32x1.5	17.0	25.0	42	36	10	1545.32.25	20



SYNTEC



Synthetic cable glands Syntec® with lamellar technology

Long entry thread metric

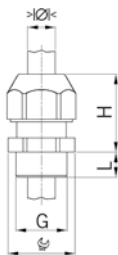

Material:	Polyamide PA 6
Properties:	halogen-free, black UV resistant (tested according to EN ISO 4892-2)
Sealing ring:	TPE or CR (Neoprene)
Strain relief:	Version A acc. to EN 62444
Protection class:	IP 68
NEMA Type rating:	4X
Operation temperature:	-30 °C / +100 °C



SYNTEC



Light grey RAL 7035
One-piece sealing ring

G	> Ø < min mm	> Ø < max mm	mm	H mm	L mm	Art.-No.	
M12x1.5	2.5	6.5	15	21	12	1555.12.1.06	100
M16x1.5	2.0	6.0	19	25	15	1555.17.1.06	50
M16x1.5	5.0	10.0	19	25	15	1555.17.1.10	50
M20x1.5	3.5	8.0	24	29	15	1555.20.1.08	50
M20x1.5	7.0	13.0	24	29	15	1555.20.1.13	50
M25x1.5	5.0	11.0	29	38	15	1555.25.1.11	25
M25x1.5	10.0	17.0	29	38	15	1555.25.1.17	25
M32x1.5	17.0	25.0	42	36	15	1555.32.1.25	20
M40x1.5	22.0	33.0	53	48	15	1555.40.1.33	10
M50x1.5	28.0	38.0	60	48	15	1555.50.1.38	5
M63x1.5	32.0	44.0	65	49	16	1555.63.1.44	5

Available on request:

Dark grey RAL 7001



SYNTEC



Black RAL 9005
One-piece sealing ring

G	> Ø < min mm	> Ø < max mm	mm	H mm	L mm	Art.-No.	
M12x1.5	2.5	6.5	15	21	12	1545.12.1.06	100
M16x1.5	2.0	6.0	19	25	15	1545.17.1.06	50
M16x1.5	5.0	10.0	19	25	15	1545.17.1.10	50
M20x1.5	3.5	8.0	24	29	15	1545.20.1.08	50
M20x1.5	7.0	13.0	24	29	15	1545.20.1.13	50
M25x1.5	5.0	11.0	29	38	15	1545.25.1.11	25
M25x1.5	10.0	17.0	29	38	15	1545.25.1.17	25
M32x1.5	17.0	25.0	42	36	15	1545.32.1.25	20
M40x1.5	22.0	33.0	53	48	15	1545.40.1.33	10
M50x1.5	28.0	38.0	60	48	15	1545.50.1.38	5
M63x1.5	32.0	44.0	65	49	16	1545.63.1.44	5

Synthetic Syntec® cable glands with lamellar technology and anti-kink nozzle

Short entry thread metric

Material: Polyamide PA 6
 Properties: halogen-free, black UV resistant (tested according to EN ISO 4892-2)
 Sealing ring: CR (neoprene)
 Strain relief: Version A acc. to EN 62444
 Protection class: IP 68
 NEMA Type rating: 4X
 Operation temperature: -30 °C / +100 °C

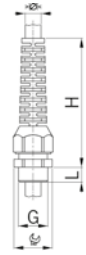

Light grey RAL 7035
 One-piece sealing ring

G	$\begin{matrix} > \ominus < \\ \text{min mm} \end{matrix}$	$\begin{matrix} > \ominus < \\ \text{max mm} \end{matrix}$	$\begin{matrix} \text{mm} \\ \text{int} \end{matrix}$	H mm	L mm	Art.-No.	
M12x1.5	2.5	6.5	15	54	6	1576.12.06	50
M16x1.5	4.0	8.0	19	64	6	1576.17.08	50
M20x1.5	3.0	7.0	24	88	8	1576.20.07	50
M20x1.5	5.5	12.0	24	88	8	1576.20.12	50



SYNTEC
 mit Knickschutz



Black RAL 9005
 One-piece sealing ring

G	$\begin{matrix} > \ominus < \\ \text{min mm} \end{matrix}$	$\begin{matrix} > \ominus < \\ \text{max mm} \end{matrix}$	$\begin{matrix} \text{mm} \\ \text{int} \end{matrix}$	H mm	L mm	Art.-No.	
M12x1.5	2.5	6.5	15	54	6	1546.12.06	50
M16x1.5	4.0	8.0	19	64	6	1546.17.08	50
M20x1.5	3.0	7.0	24	88	8	1546.20.07	50
M20x1.5	5.5	12.0	24	88	8	1546.20.12	50



SYNTEC
 mit Knickschutz





SYNTEC® brass cable gland

SYNTEC® brass cable gland with innovative lamella technology including movable jointed lamellae and overtightening-protected cap nuts for everyday use.

- Lamellae insert made from high-quality polyamide
- With short and long metric entry thread
- With environmentally resistant TPE sealing ring
- Standard/reducing sealing rings
- High level of strain relief and simultaneous distortion protection
- Protection class IP 68, waterproof
- Tested acc. to EN 62444
- Good chemical resistance

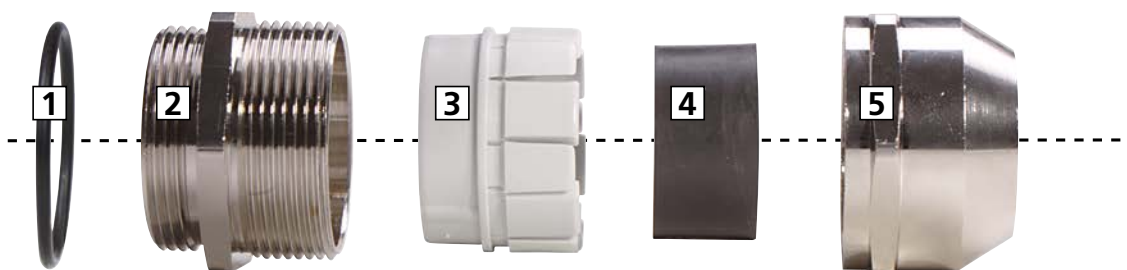

1 O-Ring | 2 Lower part | 3 Lamellar insert | 4 Sealing ring | 5 Push-down nut

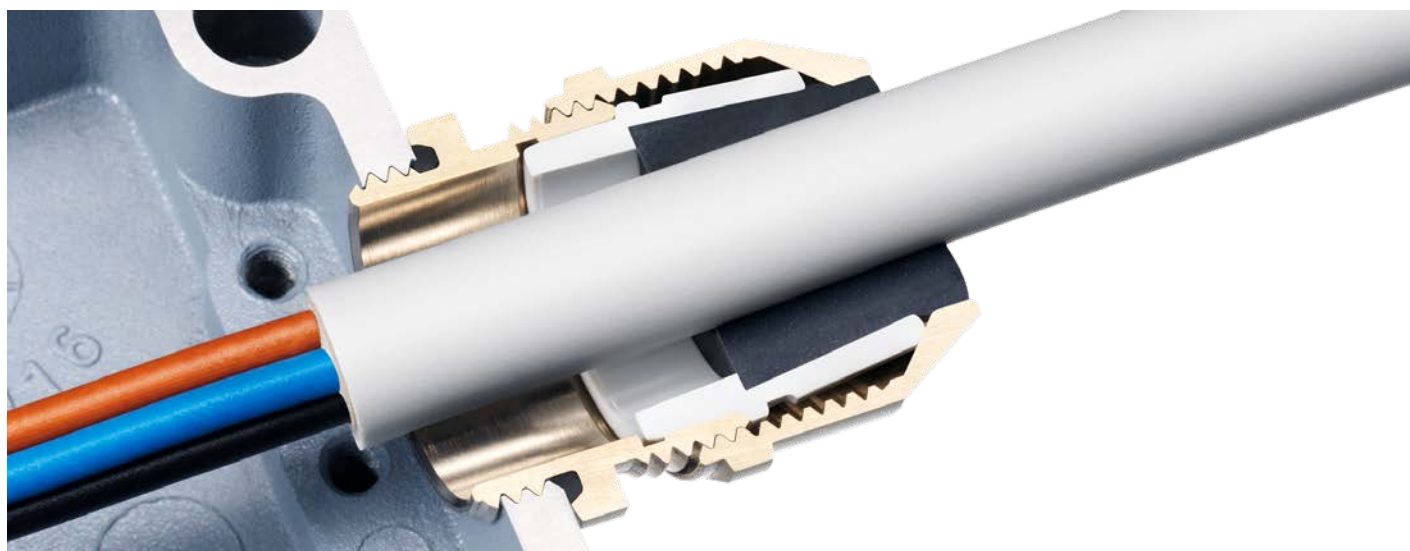

Cable glands Syntec® nickel-plated brass with lamellar technology

Short entry thread metric

Material: Nickel-plated brass
 Sealing ring: TPE
 O-ring: NBR
 Lamellar insert: Polyamide PA 6
 Strain relief: Version A acc. to EN 62444
 Protection class: IP 68
 NEMA Type rating: 4X
 Operation temperature: -40 °C / +100 °C



One-piece sealing ring
 not overall length insulated

G	$\begin{matrix} > \varnothing < \\ \text{min mm} \end{matrix}$	$\begin{matrix} > \varnothing < \\ \text{max mm} \end{matrix}$	$\begin{matrix} \varnothing \\ \text{mm} \end{matrix}$	H mm	L mm	Art.-No.	
M12x1.5	1.0	5.0	15	17	5	1045.12.050	50
M12x1.5	3.0	7.0	15	17	5	1045.12.070	50
M16x1.5	2.0	6.0	18	20	5	1045.17.060	50
M16x1.5	4.5	10.0	18	20	5	1045.17.100	50
M20x1.5	3.5	8.0	22	25	6	1045.20.080	50
M20x1.5	7.0	13.0	22	25	6	1045.20.130	50
M25x1.5	5.0	11.0	28	31	7	1045.25.110	25
M25x1.5	10.0	17.0	28	31	7	1045.25.170	25
M32x1.5	7.0	15.0	36	33	8	1045.32.150	25
M32x1.5	13.0	21.0	36	33	8	1045.32.210	25
M40x1.5	15.0	23.0	46	40	8	1045.40.230	10
M40x1.5	19.0	28.0	46	40	8	1045.40.280	10
M50x1.5	20.0	29.0	55	40	9	1045.50.290	5
M50x1.5	25.0	35.0	55	40	9	1045.50.350	5
M63x1.5	28.0	39.0	70	43	10	1045.63.390	5
M63x1.5	35.0	48.0	70	43	10	1045.63.480	5

Available on request:

Entry thread Pg



SYNTEC MS



Long entry thread metric

One-piece sealing ring
 not overall length insulated

G	$\begin{matrix} > \varnothing < \\ \text{min mm} \end{matrix}$	$\begin{matrix} > \varnothing < \\ \text{max mm} \end{matrix}$	$\begin{matrix} \varnothing \\ \text{mm} \end{matrix}$	H mm	L mm	Art.-No.	
M12x1.5	1.0	5.0	15	17	12	1145.12.050	50
M12x1.5	3.0	7.0	15	17	12	1145.12.070	50
M16x1.5	2.0	6.0	18	20	12	1145.17.060	50
M16x1.5	4.5	10.0	18	20	12	1145.17.100	50
M20x1.5	3.5	8.0	22	25	12	1145.20.080	50
M20x1.5	7.0	13.0	22	25	12	1145.20.130	50
M25x1.5	5.0	11.0	28	31	12	1145.25.110	25
M25x1.5	10.0	17.0	28	31	12	1145.25.170	25
M32x1.5	7.0	15.0	36	33	15	1145.32.150	25
M32x1.5	13.0	21.0	36	33	15	1145.32.210	25
M40x1.5	15.0	23.0	46	40	15	1145.40.230	10
M40x1.5	19.0	28.0	46	40	15	1145.40.280	10
M50x1.5	20.0	29.0	55	40	15	1145.50.290	5
M50x1.5	25.0	35.0	55	40	15	1145.50.350	5
M63x1.5	28.0	39.0	70	43	15	1145.63.390	5
M63x1.5	35.0	48.0	70	43	15	1145.63.480	5
M63x1.5	44.0	55.0	80	43	15	1145.63.550	5



SYNTEC MS



Synthetic cable glands Progress® GFK for installation of multiple cables



Synthetic cable glands Progress®

Synthetic cable glands Progress® are tried and tested helpers for correct cable entry in industrial equipment.

- Made from glass fiber reinforced, weather-resistant polyamide
- With environmentally resistant TPE sealing insert
- High level of strain relief and simultaneous distortion protection
- High chemical resistance
- Halogen-free
- Protection class IP 68
- Tested acc. to EN 62444



Entry thread metric

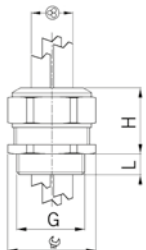

Material: Polyamide glass fiber reinforced
 Properties: halogen-free
 Seal: TPE
 Strain relief: Version A acc. to EN 62444
 Protection class: IP 68
 Operation temperature: -20 °C / +100 °C



Progress GFK multi



Light grey RAL 7035
 One-piece sealing insert

G	>Ø< min mm	>Ø< max mm	⊗	⊗ mm	H mm	L mm	Art.-No.	⊞
M16x1.5	2.0	3.0	2	21	26	12	1571.17.2.030	50
M16x1.5	2.5	4.0	2	21	26	12	1571.17.2.040	50
M16x1.5	3.5	5.0	2	21	26	12	1571.17.2.050	50
M20x1.5	3.5	5.0	2	27	28	13	1571.20.2.050	50
M20x1.5	4.5	6.0	2	27	28	13	1571.20.2.060	50
M20x1.5	5.5	7.5	2	27	28	13	1571.20.2.075	50
M20x1.5	3.5	5.0	3	27	28	13	1571.20.3.050	50
M20x1.5	4.5	6.0	3	27	28	13	1571.20.3.060	50
M20x1.5	5.2	6.5	3	27	28	13	1571.20.3.065	50
M20x1.5	3.5	5.0	4	27	28	13	1571.20.4.050	50
M20x1.5	4.5	6.0	4	27	28	13	1571.20.4.060	50
M25x1.5	5.0	7.0	2	34	33	13	1571.25.2.070	25
M25x1.5	6.7	9.0	2	34	33	13	1571.25.2.090	25
M25x1.5	7.7	10.0	2	34	33	13	1571.25.2.100	25
M25x1.5	5.5	7.0	3	34	33	13	1571.25.3.070	25
M25x1.5	6.8	9.0	3	34	33	13	1571.25.3.090	25
M25x1.5	5.5	7.0	4	34	33	13	1571.25.4.070	25
M25x1.5	4.8	6.0	6	34	33	13	1571.25.6.060	25
M32x1.5	9.0	11.5	2	41	35	15	1571.32.2.115	25
M32x1.5	7.0	9.0	3	41	35	15	1571.32.3.090	25
M32x1.5	8.5	10.5	3	41	35	15	1571.32.3.105	25
M32x1.5	7.0	9.0	4	41	35	15	1571.32.4.090	25
M32x1.5	5.8	7.0	6	41	35	15	1571.32.6.070	25

Additional versions and colours are available upon request: e.g. dark grey RAL 7001, black RAL 9005, larger entry threads

Entry thread metric

Material: Polyamide PA 6
 Properties: halogen-free
 Execution: Hexagonal design with flange
 Operation temperature: -30 °C / +100 °C

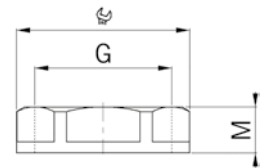

Light grey RAL 7035

G	 mm	M mm	Art.-No.	
M12x1.5	17	5.0	8255.12	100
M16x1.5	22	5.0	8255.17	100
M20x1.5	27	6.0	8255.20	100
M25x1.5	33	6.7	8255.25	100
M32x1.5	42	7.9	8255.32	50
M40x1.5	48	8.4	8255.40	50
M50x1.5	59	9.9	8255.50	10
M63x1.5	73	11.0	8255.63	10



Black RAL 9005

G	 mm	M mm	Art.-No.	
M12x1.5	17	5.0	8245.12	100
M16x1.5	22	5.0	8245.17	100
M20x1.5	27	6.0	8245.20	100
M25x1.5	33	6.7	8245.25	100
M32x1.5	42	7.9	8245.32	50
M40x1.5	48	8.4	8245.40	50
M50x1.5	59	9.9	8245.50	10
M63x1.5	73	11.0	8245.63	10



FLUSH-MOUNTING

CAVITY WALL

CONCRETE

HOUSINGS

FIRE PROTECTION

PLUGGABLE

CONNECTIVITY

CABLE GLANDS

TOOLS

SERVICE

Synthetic locking plugs

Entry thread metric

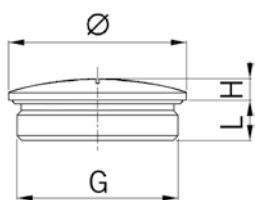

Material: Polyamide PA 6
 Protection class: IP 54
 Entry thread: IP 68, if the entry thread is sealed
 Operation temperature: -30 °C / +100 °C



Light grey RAL 7035
 without O-Ring

G	Ø mm	H mm	L mm	Art.-No.	
M12x1.5	15	4.5	6	8855.12	100
M16x1.5	20	4.5	6	8855.17	100
M20x1.5	24	4.5	6	8855.20	100
M25x1.5	30	5.0	8	8855.25	100
M32x1.5	37	5.5	8	8855.32	50
M40x1.5	46	6.0	8	8855.40	50
M50x1.5	56	6.0	10	8855.50	10
M63x1.5	70	6.0	12	8855.63	10



Black RAL 9005
 without O-Ring

G	Ø mm	H mm	L mm	Art.-No.	
M12x1.5	15	4.5	6	8845.12	100
M16x1.5	20	4.5	6	8845.17	100
M20x1.5	24	4.5	6	8845.20	100
M25x1.5	30	5.0	8	8845.25	100
M32x1.5	37	5.5	8	8845.32	50
M40x1.5	46	6.0	8	8845.40	50
M50x1.5	56	6.0	10	8845.50	10
M63x1.5	70	6.0	12	8845.63	10

Entry thread metric

Material: Nickel-plated brass
 Execution: Hexagonal design
 Operation temperature: -60 °C / +200 °C

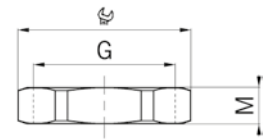

Metric thread

G	 mm	M mm	i info	Art.-No.	
M12x1.5	15	3.0	-	8000.12	100
M16x1.5	19	3.0	-	8000.17	100
M20x1.5	24	3.5	-	8000.20	100
M25x1.5	30	4.0	-	8000.25	50
M32x1.5	36	4.0	-	8000.32	25
M40x1.5	46	5.0	-	8000.40	25
M50x1.5	55	5.5	-	8000.50	10
M63x1.5	70	6.0	-	8000.63	10

1 = Metric coarse-pitch thread

Short entry thread metric

Material: Nickel-plated brass
 Protection class: IP 54
 Entry thread: IP 68, if the entry thread is sealed
 Operation temperature: -40 °C / +200 °C

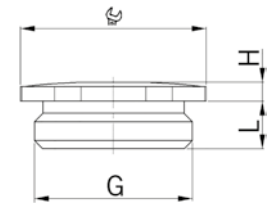

with hexagon
 without O-Ring

G	 mm	H mm	L mm	Art.-No.	
M12x1.5	14	2.5	5	8745.12	100
M16x1.5	18	2.5	5	8745.17	100
M20x1.5	22	2.5	6	8745.20	100
M25x1.5	27	3.0	7	8745.25	50
M32x1.5	34	3.5	8	8745.32	25
M40x1.5	42	4.0	8	8745.40	25
M50x1.5	52	4.0	9	8745.50	10
M63x1.5	65	4.0	10	8745.63	10

STRONGER FASTER SMARTER

Start-to-finish-victory thanks to the innovative
Evolution EMC cable gland.

EMC Technology simplified.



The **Evolution EMC** cable gland ensures the reliable and durable shield connection of shielded cables in electromobility applications. Its innovative design enables the shield contact to be repeatedly "plugged into" the cable gland's lower part, thus facilitating pre-assembly on the cable. Pre-assembled cable harnesses reduce installation costs, simplify production processes and are user-friendly. The system also allows this pre-assembly work to be carried out in the field using the battery-operated AXI PRESS tool. This enables cable harnesses to be repaired, and prototypes to be flexibly and precisely assembled. The **Evolution EMC** cable gland was specially developed for use in electrically powered vehicles and can therefore withstand the most demanding operating requirements.

1 Compression nut

Lead-free version in three sizes (M20, M25 and M32); Simplified installation; Just tighten to the stop (no torque required).

2 Sealing insert

Highest IP protection level; Anti-rotation design thanks to surface profile; Wide temperature range (-40 to +140°C).

3 Contact sleeve and supporting ring

The "pluggable" EMC shield contact solution facilitates quick and reliable installation; Ensures high-quality 360° contact.

4 Lower part

Lead-free design in three sizes (M20, M25 and M32); Large clearance for cable lugs to pass through.

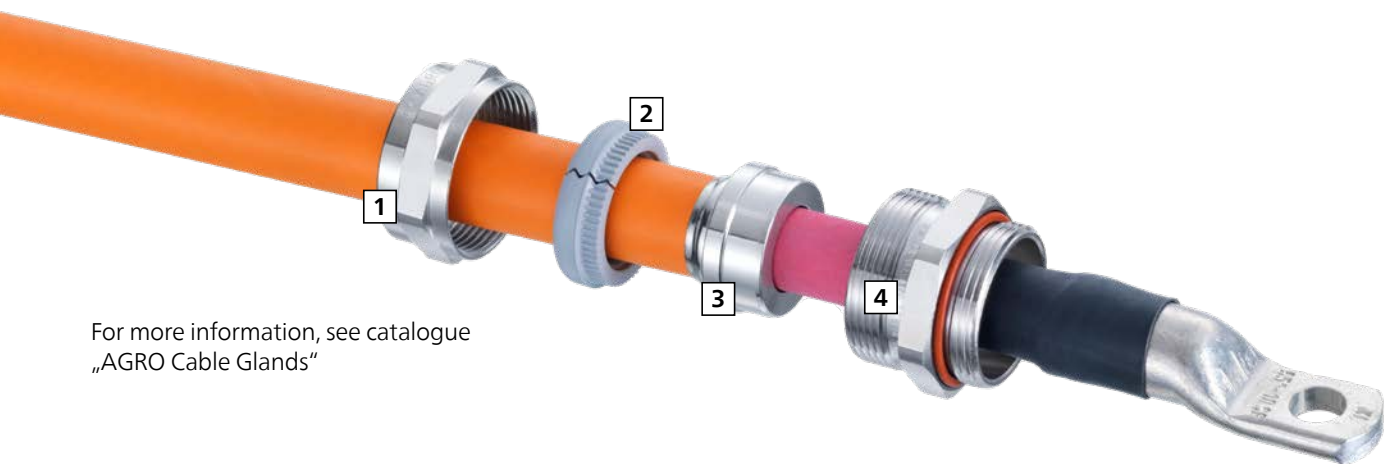

For more information, see catalogue
„AGRO Cable Glands“

Montage



1. Push the cable lug through



2. Insert the contact sleeve



3. Slide over the sealing insert



4. Tighten the pressure nut

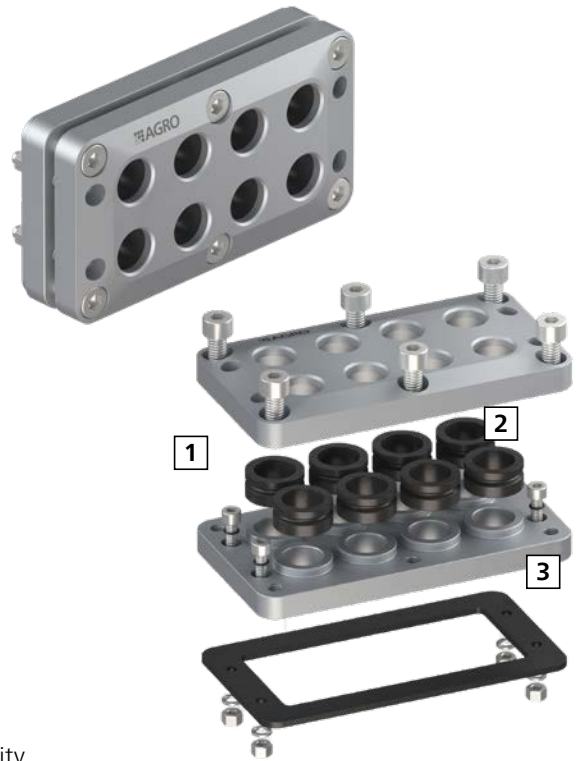
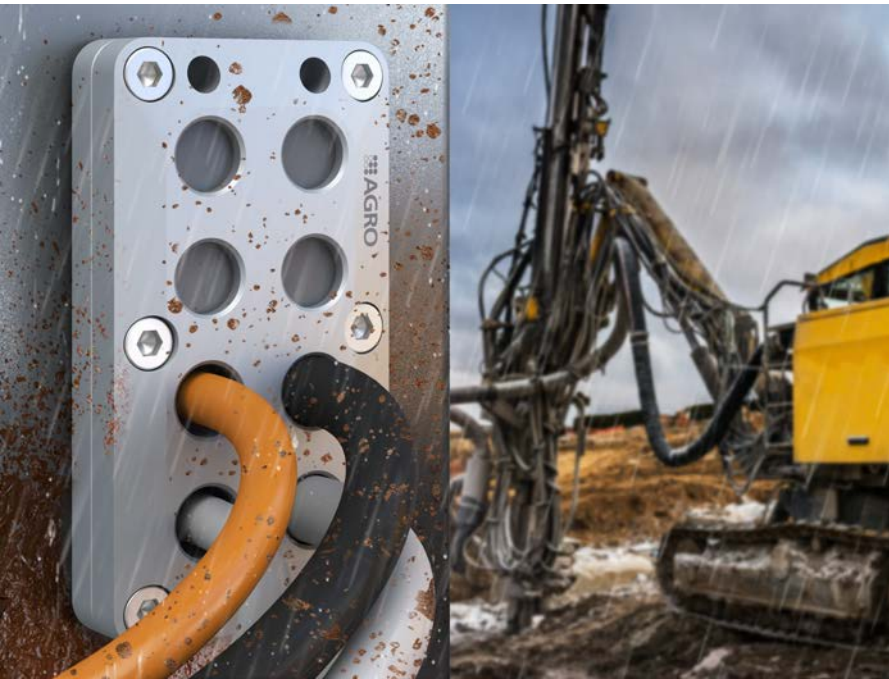

Multi Cable Entry MCE for well-sealed, process-reliable cable entries

AGRO has been developing and manufacturing high-quality cable glands in accordance with EN 62444 for over 65 years. The know-how gained from this in relation to radial compression fabrication of sealing items is now being used for the first time in cable feedthroughs. The specially-designed and reliable strain relief, together with the use of tested sealing units make MCE an innovative, extremely robust and dependable cable entry system. Multiple feedthroughs are widely used in various industries. They find application where a number of cables are to be fed, close together.

For more information, see catalogue „AGRO Cable Glands“

1 MCE system

- High process reliability
- Offers robustness and excellent sealing performance
- Also suitable for applications in challenging environments
- Pre-assembled systems can be efficiently installed on site
- No supplementary materials or lubricants needed for installation

2 Sealing elements

- Well-proven from millions of applications in standard cable glands
- Sealing according to IP68 (min. 0.1 bar for 30 minutes)
- Resistant to high pull-out forces
- Cable clamping range from \varnothing 5.5 to 21.5 mm
- Split for easy replacement if necessary

3 Housing

- High-strength half-casings of anodised aluminium
- Drilling pattern based on customary standard dimensions

General information

- Comprehensive overall programme with more than 3,500 products in our special cable gland catalogue or at www.kaiser-elektro.de
- Implementation of individual customer solutions
- CAD data

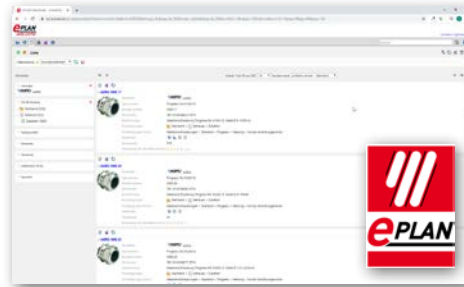
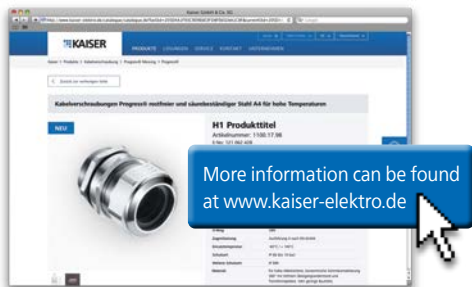

As an addition to our cable gland range, digital planning data are now also available in the EPLAN Data Portal.

Locking plug nickel-plated brass

Progress® multiLAYER, universal cable gland with maximum clamping range



Products	Nickel-plated brass	PA	TPE	CR
Description	CuZn39Pb3 Copper/zinc alloy Galvanically nickel-plated surface	Polyamide PA 6	Thermoplastic elastomer	Chloroprene rubber
Colour		As per catalogue	Black	Black
Corrosive properties Chem. resistance	Good resistance in dry atmospheres, fresh water, steam, mineral oils, fuels, coolants/lubricants and various organic emulsions	Resistant to diluted organic acids, lyes, aqueous solutions of inorganic salts, mineral oils, fuels, cooling/cutting oils	Resistant to diluted acids and lyes, aqueous solutions of inorganic salts	Resistant to diluted acids and lyes, aqueous solutions of inorganic salts, mineral oils, cooling/cutting oils
Limited or no resistance	Sea water, brackish water, damp atmospheres, acids, lyes, chloride, ammoniac	Mineral acids, concentrated organic acids, formic acid, phenols, halogens	Concentrated acids and lyes, solvents	Concentrated acids and lyes, fuels, solvents, hot water, ozone
Weather-resistance	Very good weather and ageing resistance	Good weather resistance	Good weather, ozone and ageing resistance	Good weather resistance
Constant thermal values	-40°C/+200°C	-30°C/+100°C	-40°C/+100°C	-30°C/+100°C
Combustibility	Not combustible	UL 94 V-2 halogen-free	Comparable to UL 94 HB halogen-free	Comparable to UL 94 V-2 halogen-free

1st digit Degree of protection against contact/foreign body protection		2nd digit Degree of protection against ingress of water	
IP testing		IP testing	
	0 No protection		0 No protection
<p>∅ 52,5 mm</p>	1 Protection against ingress of solid foreign bodies larger than 50 mm (unintentional touching by hand).		1 Protection against water dripping from above.
<p>∅ 12,5 mm</p>	2 Protection against ingress of solid foreign bodies larger than 12 mm (touching with fingers).		2 Protection against dripping water falling at an angle of up to 15°.
<p>∅ 2,5 mm</p>	3 Protection against ingress of solid foreign bodies larger than 2.5 mm (touching with tools, wires etc. thicker than 2.5 mm).		3 Protection against spray falling at any angle up to 60°.
<p>∅ 1 mm</p>	4 Protection against ingress of solid foreign bodies larger than 1 mm (touching with tools, wires etc. thicker than 1 mm).		4 Protection against splashes from any direction.
	5 Complete protection against contact. Protection against harmful dust deposits — penetration of dust is not completely prevented.		5 Protection against jets of water from any direction.
	6 Complete protection against contact. Protection against dust penetration.		6 Protection against temporary flooding e.g. by high seas.
			7 Protection against submersion in water at a specified pressure for an unspecified time.
			8 Protection against submersion in water at increased pressure for an unspecified time.
			9K Protection against the penetration of water during high-pressure (80-100 bars), high-temperature washdown applications (80° C)

Note

IP**: Protection class in accordance with EN 60529 up to 1000 V » and 1500 V = (UTE Standard C 200 10) or acc. to DIN 40059-9 We carry out tests for protection class IPx8 (pressure water) with a test plug, which does not provide any information about the maximum pressure with a cable. Please contact us if you want us to calculate this value in our laboratory using your cable.

MontaX mounting plate



MontaX mounting plate for attaching all types of devices and components in building interiors. May be used in plant engineering, machine construction and switchboard plants and for heating, ventilation and air conditioning applications, etc.

- More than 200 attachment possibilities
- Secure and fast installation of many devices



MontaX mounting plate

- over 200 fixing methods for accessories
- Injection-moulded connectors allow surfaces to be joined together effortlessly to form larger units
- Mounting plate can be split into two identical halves
- Attachment to cable ducts, round or square conduits, TS 35 standard profiles, etc.
- Magnet attached for adjustable mounting



Length x Width x Height	180 x 90 x 13 mm
Art.-No.	2000-00
Inner packaging/shipping	- / 10

MontaX mounting angle

MontaX mounting angle for secure attachment in almost all orientations and angles. With only one element, the MontaX mounting angle gives you 200 attachment possibilities in four different angular positions on standard profiles, square or round conduits, steel beams etc.

- For easy visual inspection of counters, indicator light etc.
- For easy and safe operation of switches etc.
- No voltage transfer as all plastic



Processing instructions



Mounting angle for MontaX

- for 30°, 45°, 60° & 90° angular attachment of MontaX to vertical axis
- simple straightening and attaching with 4.5 mm Ø raised head screws through keyholes
- mounting plate can be attached using self-tapping 3.9 mm Ø flat-head screws in mounting grooves



Art.-No.	2000-80
Inner packaging/shipping	- / 5

MontaX - Magnet

- for adjustable mounting
- comes with fixing screw



Art.-No.	2000-90
Inner packaging/shipping	- / 5



Flush-mounting

- Grinding heads for flush-mounting installation
- High precision and durability
- Professional system tools for professional and safe installation



Heat-insulation

- Tools for installation in insulation systems
- Professional system tools for professional and safe installation
- Reliable quality and innovative technology

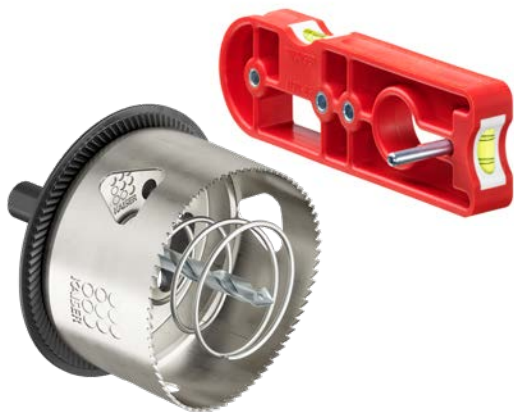















Cavity wall

- Cutter for cavity wall installation
- Professional system tools for fast and safe installation
- Proven quality and innovative technology



System tools

- Professional system tools for precise opening of boxes and housings
- Perfectly matched to the processing and installation of KAISER electrical installation products

			 <i>Diamond grinding head for dust extraction 1088-02 pg. 379</i>	 <i>Diamond grinding head for dust extraction 1088-03 pg. 379</i>	 <i>Diamond grinding head without dust extraction 1088-00 pg. 380</i>	 <i>Diamond grinding head without dust extraction 1088-01 pg. 380</i>
Properties						
Drill hole diameter			82 mm	68 mm	82 mm	68 mm
Drill hole depth, max.			80 mm	80 mm	80 mm	80 mm
With side slots			-	-	✓	✓
With holes for dust extraction			✓	✓	-	-
Number of segments			4	3	4	3
Entry thread			M 18×1.5	M 18×1.5	M 18×1.5	M 18×1.5
Materials						
	Limestone		✓	✓	✓	✓
	Vertically perforated brick		✓	✓	✓	✓
	Lightweight concrete		✓	✓	✓	✓
	Cellular concrete		✓	✓	✓	✓
Compatible accessories (optional)						
	Dust extraction	1088-41	✓	✓		
	Dust extraction	1088-16	✓	✓		
	Dust extraction	1088-21	✓	✓		
	Chuck attachment	1088-40			✓	✓
	Direct attachment	1088-15			✓	✓
	Direct attachment	1088-20			✓	✓

FLUSH-MOUNTING
CAVITY WALL
CONCRETE
HOUSINGS
FIRE PROTECTION
PLUGGABLE
CONNECTIVITY
CABLE GLANDS
TOOLS
SERVICE



Diamond grinding head

Diamond grinding head for precise and quick installation openings for one-gang boxes and one-gang junction boxes in practically all types of walls. Clean and low-dust handling due to dust extraction.

- Quick creation of installation openings in all types of walls
- For electric drills with direct attachment or 13 mm chuck
- With optional dust extraction

Installation



Pre-drilling. Create centering hole at a combination distance for multiple boxes using drilling template.



Fit diamond grinding head and drill holes at Ø 68 mm or Ø 82 mm.



Chisel out the drill core completely.



Clean and even installation openings for quick box installation with plaster or KLEMMFIX®.

System overview – with and without dust extraction

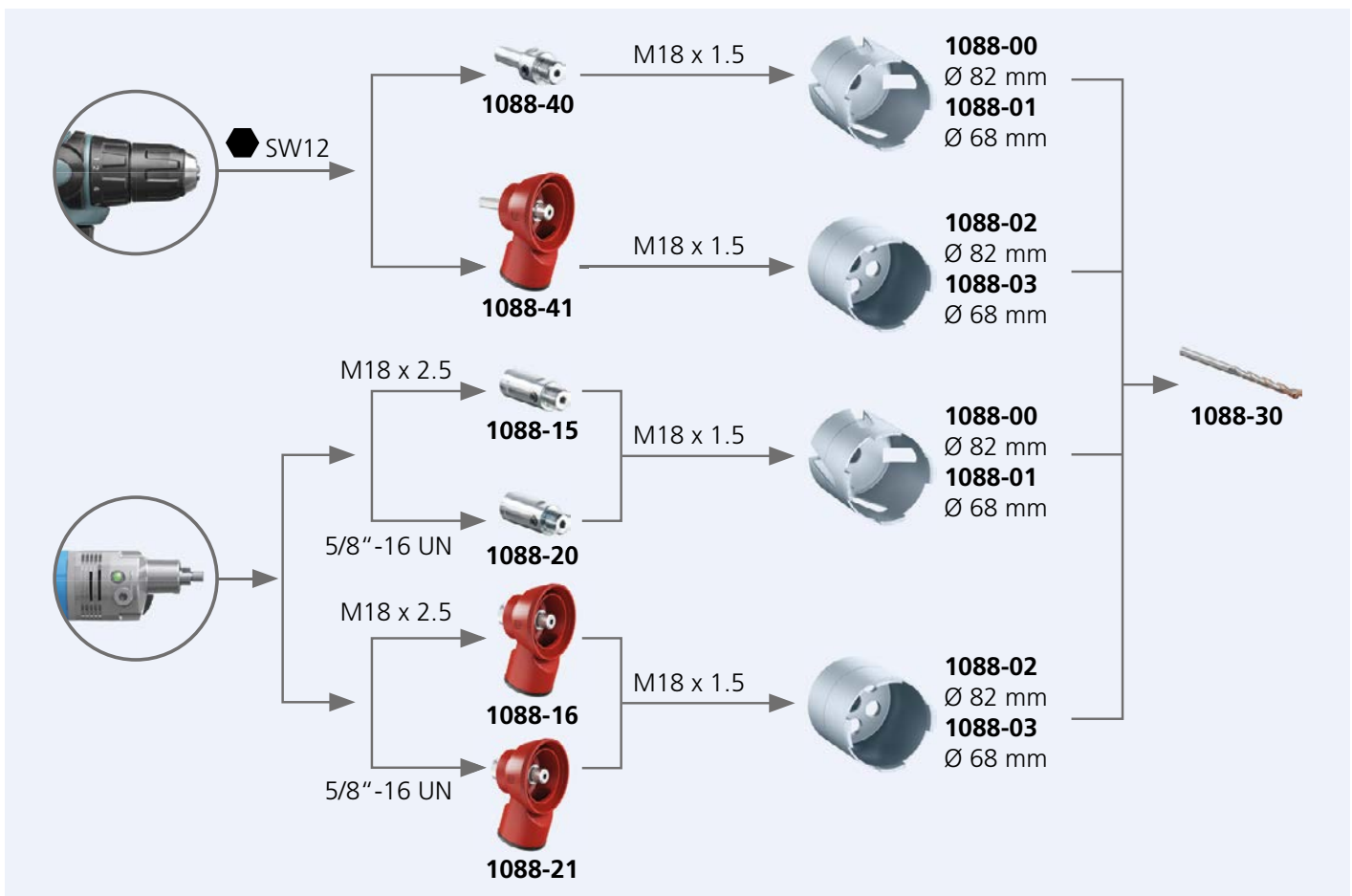

Diamond grinding head with dust extraction

- Universal area of application
- For medium-hard masonry
- High service life
- Entry thread M18 x 1.5
- for screwing onto the dust extraction system



3D animation

Drill Ø	82 mm	68 mm
Cutting depth	max. 80 mm	max. 80 mm
Art.-No.	1088-02	1088-03
Inner packaging/shipping	- / 1	- / 1

Dust extraction with direct attachment / chuck attachment

- for diamond grinding heads Ø 82 or Ø 68 mm with connection thread M18x1.5
- Vacuum cleaner hose attachments from Ø 31 - 36 mm



UN-Thread for Bosch and Flex	5/8"-16 UN	-	-
ISO thread	-	M18 x 2,5	-
Chuck attachment with hexagonal	-	-	12 mm
Art.-No.	1088-21	1088-16	1088-41
Inner packaging/shipping	- / 1	- / 1	- / 1

Health hazards due to construction dust

When drilling holes, fine dust is produced which, when inhaled, can penetrate deep into the lungs via the bronchial tubes and lead to serious health problems. The quartz dust produced when drilling into concrete, bricks and sandstone is particularly dangerous and can cause asthma, silicosis and tumours in the nose, sinuses, throat and lungs, among other things, as a long-term consequence. There is also the risk of asbestosis (pneumoconiosis) during renovation work in older buildings, as plasters, fillers and tile adhesives containing asbestos were still used until the ban on asbestos in 2005. Safe dust protection on the construction site is therefore extremely important for the health and safety of the workers. The most effective measure is the use of the KAISER dust extraction directly at the point of origin, which is available as a customised system with the KAISER diamond grinding head.



Flush-mounting and masonry tools

For masonry installation

Diamond grinding head without dust extraction

- Universal area of application
- For medium-hard masonry
- High service life
- Entry thread M18 x 1.5
- with side slits
- for screwing onto the direct attachment

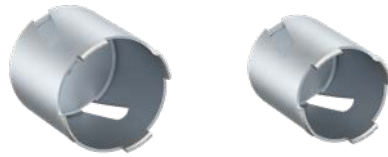

3D animation

Drill Ø	82 mm	68 mm
Cutting depth	max. 80 mm	max. 80 mm
Art.-No.	1088-00	1088-01
Inner packaging/shipping	- / 1	- / 1

Direct attachment / chuck attachment

- for screwing onto the electric drill spindle (Art. No. 1088-15, 1088-20)
- for clamping in the drill chuck (Art. No. 1088-40)



Connection drilling machine: internal thread	5/8"-16 UN	M18x2,5	-
Connection grinding head: External thread	M18x1,5	M18x1,5	M18x1,5
Connection drilling machine: hexagon	-	-	12 mm
Art.-No.	1088-20	1088-15	1088-40
Inner packaging/shipping	- / 1	- / 1	- / 1

Centering drill

- for all direct and chuck attachments
- with carbide cutter
- Drill length: 125 mm



Diameter	6 mm
Art.-No.	1088-30
Inner packaging/shipping	- / 1

Drilling template

Drilling template for exact positioning of the centring holes for creating installation openings in masonry. The drilling template can be used to reliably and precise to create vertical or horizontal combination distances. This ensures that box combinations and subsequent switches and connectors can be professionally installed without reworking.

- Drilling template for exact marking of the centering hole
- For creating installation openings at the exact distance
- Suitable for masonry and drywall construction
- Vertical and horizontal application possible



Installation



Drill the first hole \varnothing 6 mm at the intended position.

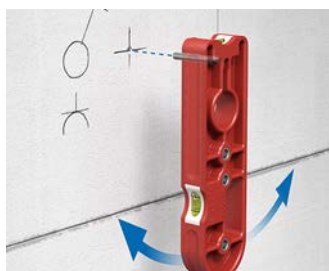

Insert the guide pin into the hole and align the template horizontally or vertically using the spirit levels.



Further holes are drilled through the drill bushes.



The centring holes created serve as a precise guide for the diamond core bit.

Drilling template

- 2 spirit levels for vertical and horizontal alignment
- 71 mm for standard combinations
- 91 mm for separate covers on low-voltage equipment
- with hardened drilling bushes \varnothing 6 mm
- with fold-out guide pin for first drill hole



Art.-No.	1190-65
Inner packaging/shipping	- / 1

Marking chalk

- for marking of switch symbols and wiring instructions
- Colour: blue, waterproof



Art.-No.	1190-55
Inner packaging/shipping	- / 12



Spirit level cover

Spirit level cover for quick and exact precisely positioning of one-gang boxes and one-gang junction boxes in the masonry. The application is possible for both individual boxes and combinations of boxes.

- For all KAISER one-gang boxes and one-gang junction boxes, except UP¹ flush-mounting boxes
- Guaranteed horizontal or vertical fit of the screw domes
- Quick assembly in a single action

Installation



Prepare the wall opening with plaster as usual.



Insert the spirit level cover into the upper box.



Push the box combination into the wall opening and align.



The spirit level immediately indicates the perfect fit.

Spirit level cover

- practical box spirit level
- To straighten one-gang boxes and one-gang junction boxes for horizontal and vertical assembly with plaster



Art.-No.

1190-60

Inner packaging/shipping

5 / 100

Suitable material*		recommended revolutions per min ⁻¹							
Mineral Materials	Plasterboard	1.000	800	800			500–1.200	700–1.400	
	Plaster fibre	800		600			400–800	600–1.200	
	Cement fibre	800		600				600–1.200	
	Insulation to plaster	800	500						
Wood materials	Plywood uncoated P2 (V20)		400	800	800		400–600	800–1.400	
	Plywood, coated			800				800–1.400	
	OSB panels	600		600	600				
	MDF panels				800 ¹			800–1.400	
	HPL panels			400				800–1.400	
	Plywood (Multiplex, screen printing)			600			400–800		
	Wooden slat, soft (poplar, spruce)		500	800	800			800–1.400	
	Wooden slat, hard (larch, birch, beech, oak)			600	800			800–1.400	
	Solid / laminated wood				600 ¹				
Metals	Sheet steel ³						150 ²	200–600 ²	
	Aluminium sheet						200	300–500	200–600
Others	Laminate (Pertinax)			400					
	Plastics (PVC, PP, PE)		300						
Cut hole Ø									
	20 mm	✓							
	35 mm							✓	
	68 mm		✓	✓	✓	✓	✓		
	74 mm			✓	✓		✓		
	79 mm							✓	
	83 mm							✓	
	86 mm							✓	
	120 mm							✓	
	65–120 mm								✓
Technical properties									
	with slot and centering drill	✓	✓	✓	✓	✓	✓	✓	✓
	with countersink			✓	✓	✓		(✓)	
	Trilo geometry			✓	✓				
	Tooth type ⁴	HM	WS+HM	WS	HM	HM	BiM	BiM	HM
	with dust extraction								✓
Compatible accessories (optional)									
	Dust extraction	1088-50		✓	✓				
	Quick ejector	1083-81		✓	✓				
	Distance cutter, Profix	1083-...		✓	✓	✓	✓		
	WDVS centring aid	1090-68	✓						
	Centering insert 68/74	1083-99		✓					

* Use only in a suitable material; ¹ ventilate frequently; ² Use cutting oil / coolant; ³ up to a thickness of 1 mm; ⁴ WS: Tool steel · HM: Carbide metal · BiM: BiMetal



SPECIAL cutter for insulating boards

Retrofitting electrical connections to an already completed, insulated facade is a challenge. The SPECIAL cutters can be used to create installation openings without weakening the external composite thermal insulation system, as insulation is only removed at certain points.

- with depth stop to prevent heat bridges
- Hardened metal teeth enable use even with plastering
- easy removal of the drilled core

SPECIAL cutter Ø 20 x 80 mm for KAISER mini equipment carrier



The SPECIAL cutter Ø 20 x 80 mm with carbide cutters for exact installation openings. (Art. No. 1088-06).



The drilling depth stop ensures that only the amount of insulation material is removed that is necessary to secure the mini equipment carrier.



By simply unscrewing the cutter head, the drilled core can be removed quickly using a centering drill.



The insulating capacity remains intact despite the installation opening.

SPECIAL cutter ETICS Ø 20 x 80 mm

- Making installation openings in existing composite thermal insulation systems or lightweight walls
- Ø 20 mm, for the KAISER mini equipment carrier and for KAISER cable seals
- with depth stop to prevent heat bridges
- with hardened metal centering drill for precise positioning
- fits all battery-powered drills and electric drills with 10 mm chuck
- removable cutter head for easy removal of the drilled core



3D animation

Length	80 mm
Drill Ø	20 mm
Cutting depth	max. 60 mm
Art.-No.	1088-06
Inner packaging/shipping	- / 48

SPECIAL cutter Ø 68 x 180 mm for one-gang junction boxes ECON® Styro55



If a cable is present, you can drill 68 mm installation openings using even with the SPECIAL cutter.



The centering aid Ø 68 mm and depth stop on the cutter ensure a precise opening without damaging the existing cable.



The depth stop ensures minimal interference with the insulation, which prevents the creation of heat bridges.



KAISER SPECIAL cutter with depth stop, (Art. No. 1088-07).

Processing instructions

Make sure that the cable has been vertically fed through the insulation material panel. The SPECIAL cutter Ø 68 x 180 mm must not be used with cables which are directly under the plaster layer of the external insulation.

SPECIAL cutter ETICS Ø 68 x 180 mm

- Creating installation openings in existing external thermal insulation composite systems for an existing cable
- for ECON® Styro55 one-gang junction boxes
- fits all electric drills with 13 mm chuck
- with depth stop to prevent heat bridges
- including 2 centering aids Ø 68 mm (Art. No. 1090-68) for exact cutter guiding



3D animation

Length	180 mm
Drill Ø	68 mm
Cutting depth	max. 70 mm
Art.-No.	1088-07
Inner packaging/shipping	- / 1

Centering aid Ø 68 mm

- for precise installation openings in existing external composite thermal insulation systems (ETICS)
- precise guidance of the SPECIAL cutter (Art. No. 1088-07)
- can be combined for standard combinations of 71 mm
- for exact positioning and easy fixing by nailing to the insulation board



ECON® Iso + / ECON® Styro 55 setting tool

- for fast and secure fixing of the ECON® Iso + (Art. No. 1159-55) and ECON® Styro55 (Art. No. 1555-51) one-gang junction box



Diameter	68 mm	-
Art.-No.	1090-68	1090-22
Inner packaging/shipping	10 / 100	10 / 100



PROFI cutter

The new PROFI cutter is the ideal tool for creating installation openings in drywalls. The fine saw teeth and precise drilling diameter are perfectly matched to the installation of KAISER boxes. The innovative trilo geometry of the cutter head ensures an improved operating life. In combination with the new centring drill, the drilled core can be reliably ejected, enabling fast work.

- longer service life due to new cutting edge geometry
- Faster installation thanks to reliable drilled core ejection
- With holder, centring drill, countersink hole cutter and drilled core ejector
- Specially for plasterboard, softwood and plywood boards
- Unique triangular-round cutter geometry for maximum hole precision



Technical information



Optimised cutting performance thanks to the innovative trilo geometry of the saw teeth.



PROFI cutter including holder, centring drill, spring and countersink hole cutter.



PROFI cutter for optimum installation openings in dry-wall walls and ceilings with plasterboard boarding.

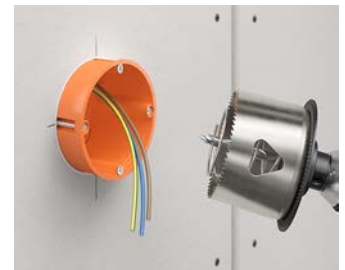

Exact openings enable the professional installation of cavity wall boxes.

PROFI cutter

- high cutting power
- precise cut for circular drilled holes
- high radial runout accuracy
- Removable countersink hole cutter
- fits all electric drills with 13 mm chuck



3D animation

Cut hole Ø	68 mm	74 mm
Depth of cutting hole	32 mm	32 mm
with countersink hole saw	Yes	Yes
with ejector spring	Yes	Yes
Art.-No.	1081-10	1081-20
Inner packaging/shipping	- / 10	- / 10

PROFI cutter head

NEW

INNOVATION

- high cutting power
- precise cut for circular drilled holes
- high radial runout accuracy



Cut hole Ø	68 mm	68 mm	74 mm	74 mm
Depth of cutting hole	32 mm	32 mm	32 mm	32 mm
with ejector spring	Yes	-	Yes	-
Art.-No.	1081-11	1081-12	1081-21	1081-22
Inner packaging/shipping	- / 5	- / 5	- / 5	- / 5

PROFI countersink hole cutter

NEW

- for flush-mounting box and casing installation
- inductively hardened



for PROFİ cutter Ø	68 mm	74 mm
Art.-No.	1081-15	1081-25
Inner packaging/shipping	- / 1	- / 1

Centering insert 68/74 mm – operation

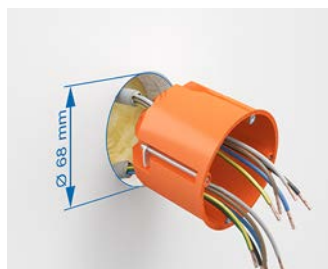

The traditional box is removed from the Ø 68 mm installation opening

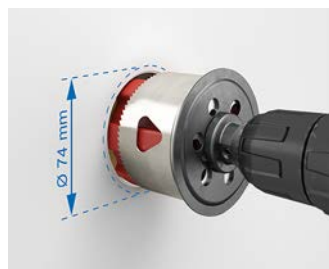

Centering insert 68/74 (Art. No. 1083-99) is inserted into the existing opening together with the Ø 74 mm cutter (e.g. PROFİ, Art. No. 1081-20).



The existing opening can easily be expanded to Ø 74 mm



Now the traditional installation box can be replaced by a sound insulation, fire protection or radiation protection box.

Centering insert 68/74

- for expanding existing installation openings from Ø 68 mm to Ø 74 mm
- precise guide for KAISER PROFİ cavity wall cutter
- for single and multi-layer boarded light-weight walls and ceilings



Diameter	68 mm
Art.-No.	1083-99
Inner packaging/shipping	10 / 100



EXPERT cutter

The new EXPERT cutter is the ideal tool for creating installation openings in drywalls with increased requirements. Carbide teeth enable use in hard materials and guarantee maximum operating life. The high dimensional accuracy guarantees precise and professional installation of KAISER boxes.

- longest service life due to carbide teeth
- Faster installation thanks to reliable drilled core ejection
- With holder, centring drill, countersink hole cutter and drilled core ejector
- Cutting diameter 68 mm and 74 mm
- Multifunctional use in almost all board materials
- Unique triangular-round cutter geometry for maximum hole precision



Technical information



Optimised cutting performance thanks to the innovative trilo geometry of the saw teeth.



EXPERT cutter including holder, centring drill, spring and carbide countersink hole cutter



EXPERT cutter for dimensionally accurate installation openings in hard board materials or combinations.



Exact openings enable the professional installation of cavity wall boxes.

EXPERT carbide cutter

- Carbide tipped cutter head and countersink hole cutter
- extremely powerful
- very long operating life
- Removable countersink hole cutter
- fits all electric drills with 13 mm chuck



3D animation

Cut hole Ø	68 mm	74 mm
Depth of cutting hole	35 mm	35 mm
with countersink hole cutter and ejector spring	Yes	Yes
Art.-No.	1082-30	1082-40
Inner packaging/shipping	- / 10	- / 10

EXPERT carbide cutter head

NEW

- carbide tipped
- extremely powerful
- very long operating life



Cut hole Ø	68 mm	68 mm	74 mm	74 mm
Depth of cutting hole	35 mm	35 mm	35 mm	35 mm
with ejector spring	Yes	-	Yes	-
Art.-No.	1082-31	1082-32	1082-41	1082-42
Inner packaging/shipping	- / 5	- / 5	- / 5	- / 5

EXPERT carbide countersink hole cutter

NEW

- carbide tipped
- for flush-mounting box and casing installation

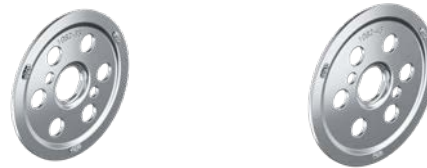

for EXPERT cutter Ø	68 mm	74 mm
Art.-No.	1082-35	1082-45
Inner packaging/shipping	- / 1	- / 1

Collets

NEW

- with centering drill Ø 6 mm
- for all PROFI, EXPERT and BASIC cavity wall cutters



Entry thread	5/8" – 18 UNF	5/8" – 18 UNF
for 13 mm chuck	Yes	-
for 10 mm chuck	-	Yes
Art.-No.	1083-40	1083-41
Inner packaging/shipping	- / 1	- / 1

Ejector spring

- Assembly instructions: clamp the cutter, pull off the old spring with the tool and press the new spring over the collar at the bottom of the cutter head with the tool.
- for all PROFI and EXPERT cavity wall cutters



NEW

Art.-No.	1083-50
Inner packaging/shipping	- / 5

Centering drill

- Cylindrical shank with clamping surface
- for all PROFI, EXPERT and BASIC cavity wall cutters, as well as dust extraction and quick ejectors
- extra centre angle



NEW

Diameter	6 mm
Art.-No.	1083-60
Inner packaging/shipping	5 / -

Quick ejector for cavity wall cutter



NEW

INNOVATION

The quick ejector enables the drilled core to be ejected quickly and reliably using the safety push handle. The adapter allows different cutter heads to be mounted and easily changed depending on the application.

- Exact drilling due to advance drill
- Solid and high-quality components ensure a long service life
- System solution matched to the KAISER PROFI and EXPERT cavity wall cutters

Quick ejector – Operation



Create drill hole.

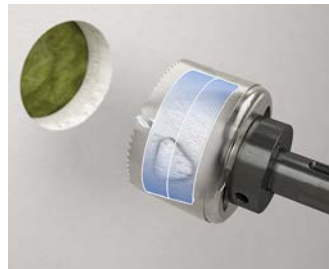

Drilled core remains in the cutter head.

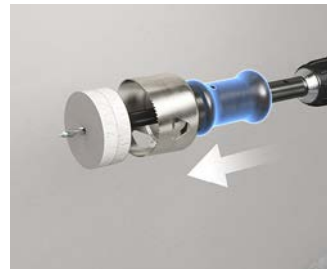

Push out and remove the drilled core using the push handle.

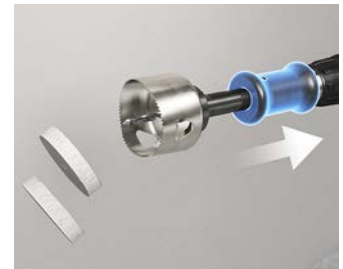

Push the push handle back to the starting position.

System overview – Quick ejector for cavity wall cutters

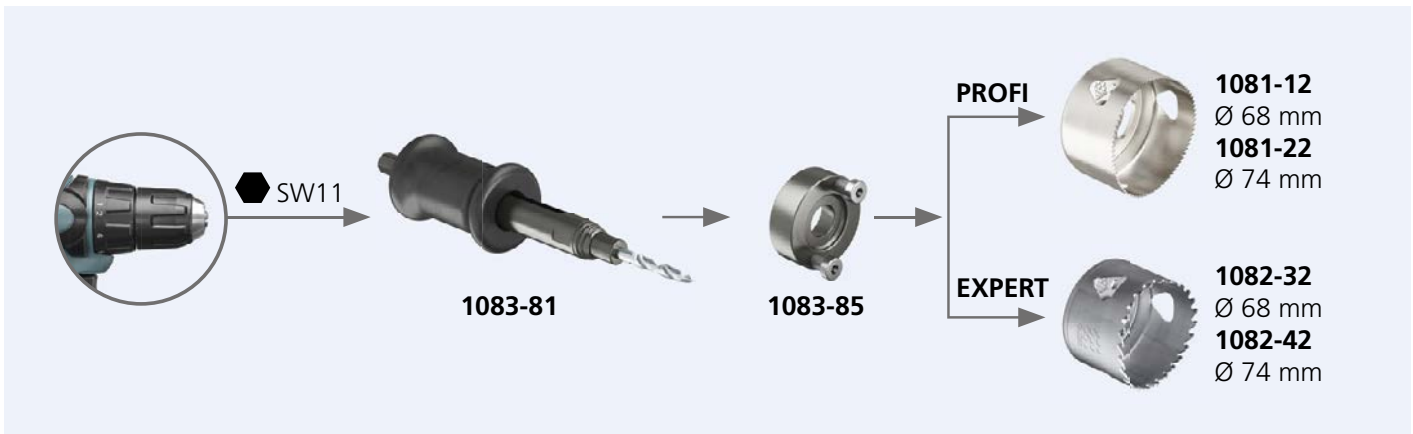

Quick ejector set

NEW

- including KAISER PROFI cutter head Ø 68 mm with adapter
- with centering drill Ø 6 mm
- Allen key 2.5 and 5 mm



INNOVATION

Entry thread drill holder hexagonal shank	11 mm
Art.-No.	1083-80
Inner packaging/shipping	- / 1

Quick ejector shaft

NEW

- Exclusively for PROFI or EXPERT cutter heads Ø 68 or Ø 74 mm
- including cutter adapter
- with centering drill Ø 6 mm
- Allen key 2.5 mm



Entry thread drill holder hexagonal shank	11 mm
Art.-No.	1083-81
Inner packaging/shipping	- / 1

Quick ejector adapter

NEW

- Exclusively for PROFI or EXPERT cutter heads Ø 68 or Ø 74 mm
- Adapter for using cutter heads on the quick ejector shaft



Art.-No.	1083-85
Inner packaging/shipping	- / 1

Safe and reliable - create installation openings using a quick ejector

The adapter (Art. No. 1083-85) can be used to mount different cutter heads on the quick ejector. Depending on the application, you can choose between the two cutter heads PROFI and EXPERT. Both diameters 68 and 74 mm are compatible, and the use of a rim countersink is also possible. To do this, the cutter head simply needs to be fitted once with an adapter and then screwed onto the quick ejector shaft. Thanks to the special thread, it is easy to change. At the same time, this backlash-free mounting ensures perfect concentricity of the cutter head and thus dimensionally accurate installation openings.





NEW

INNOVATION

Dust extraction for cavity wall cutters

The dust extraction system for cavity wall cutters effectively prevents the formation of dust when creating installation openings for installation boxes in drywalls or built-in luminaires in suspended ceilings.

- Reduction of dust pollution on the construction site
- Ideally suited for subsequent installation in existing buildings
- System solution matched to the KAISER cavity wall cutters
- For all electric drills with 13 mm chuck

Application examples



Cleanliness during ceiling installation, e.g. for spotlights, especially when retrofitting.



Using the extraction system prevents the release of hazardous dust and increases the operating life of the cutter head.



Dust extraction is compatible with the PROFI and EXPERT Ø 68 / 74 mm cutter heads.



The special contour in the cutter heads enables reliable extraction of drilling dust.

System overview – Dust extraction for cavity wall cutters

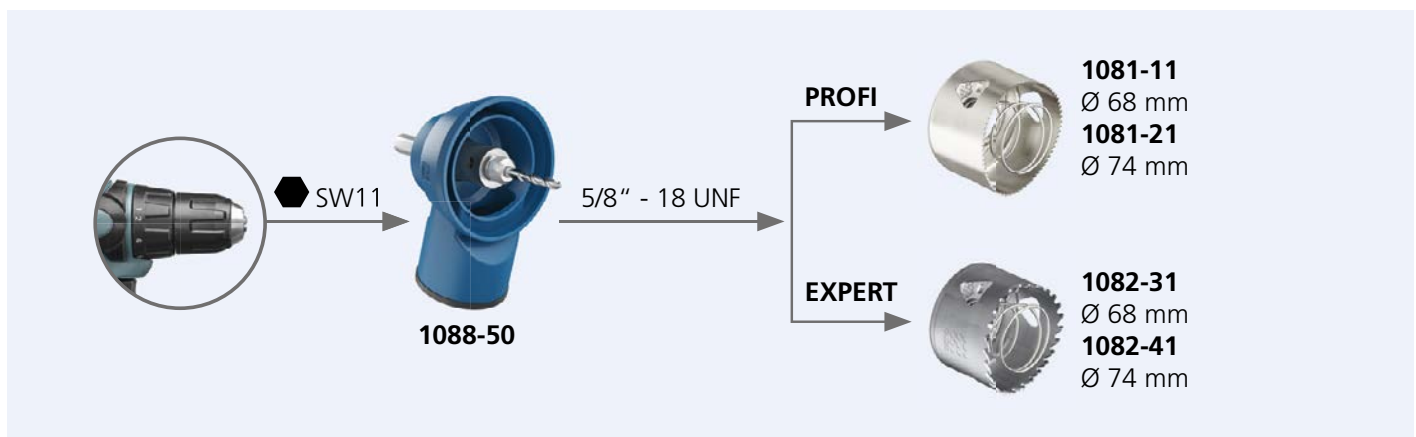

Dust extraction for cavity wall cutters

NEW

- Exclusively for PROFI or EXPERT cutter heads Ø 68 or Ø 74 mm
- Vacuum cleaner hose attachments from Ø 31 - 36 mm
- Including centring drill Ø 6 mm



Entry thread	5/8" – 18 UNF
Entry thread drill holder hexagonal shank	11 mm
Art.-No.	1088-50
Inner packaging/shipping	- / 1

Prevent dust from forming in the first place

The dust particles produced when cutting box holes in drywall or timber construction are often underestimated. This also poses enormous risks for the trade carrying out the work: inhaling plaster and wood dust can also lead to long-term damage, such as cancer in the nose and sinuses, and can cause dangerous pneumoconiosis. Extracting dust directly at the cutting point with the new KAISER dust extraction system for cavity wall cutters is the most efficient method for working with low dust levels and protecting the health of the craftsman.



Distance cutter, Profix



Profix, the bit for electric drills for quick and precise cutting of Ø 68 mm installation openings at the standard distance. Can be used in cut openings or existing cavity wall boxes. Available with and without dust extractor.

- With spirit level for exact insertion of horizontal and vertical combinations
- Standard distance of 71 mm or 91 mm without time-consuming measuring and marking
- For expansion of existing cavity wall box combinations
- For electric drills with Ø 43 mm euro clamping collar
- centering plate can also be used in existing cavity wall boxes for the expansion of existing equipment

Distance cutter Profix – operation



Distance 71 mm: Cut first opening as usual. Insert centering plate into first opening and cut second opening.



Adjust from 71 to 91 mm: Pull back clip nose with spring and turn centering plate by 180°.



Move centering plate to new position and lock centering plate.

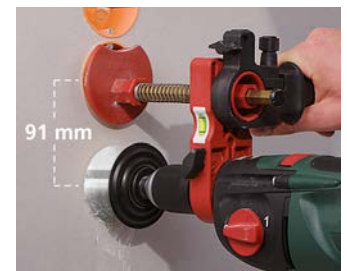

Distance 91 mm: Insert centering plate into existing hole or box, align and cut additional opening.

Distance cutter, Profix

- for the cutting of cavity wall installation openings with dimensionally accurate combination distances of 71 mm, optionally adaptable to a distance of 91 mm
- for horizontal and vertical combinations



Up to 13 mm chuck	Yes	-	Yes	-
for SDS-plus quick-change chuck	-	Yes	-	Yes
with dust extractor	-	-	Yes	Yes
Art.-No.	1083-25	1083-28	1083-27	1083-29
Inner packaging/shipping	- / 10	- / 1	- / 1	- / 1

Cavity wall box template

- for marking cutting-out distances for boxes combinations
- standard combination distance 71 mm to German DIN 49 075 as well as 91 mm distance for separate covers for low-voltage equipment



Art.-No.	1085-99
Inner packaging/shipping	- / 100

SPECIAL cutter

The SPECIAL cutters are the ideal tool for creating installation openings in demanding materials. Specially developed for processing metal and wood materials, it ensures precise and professional installation.

- METAL cutter with fine tothing
- for smooth running and precise holes
- MDF cutter with carbide teeth
- for fast cuts and long operating life



SPECIAL cutter METAL

- specially for sheet metal panelling made of unalloyed/alloyed steels, non-ferrous metals
- Fine bi-metal tothing 10 teeth pi
- special centering drill for exact drilling
- fits all electric drills with 13 mm chuck

NEW

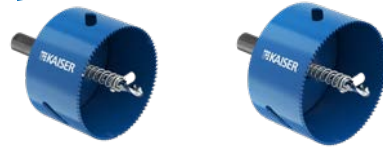

Cut hole Ø	68 mm	74 mm
Depth of cutting hole	32 mm	32 mm
with ejector spring	Yes	Yes
Art.-No.	1086-68	1086-74
Inner packaging/shipping	- / 10	- / 10

SPECIAL cutter MDF Ø 68 mm

- especially for medium density fibreboard MDF
- very suitable for wood materials
- with countersink hole cutter, holder and centering drill
- ground carbide teeth for fast cutting
- no clogging due to large chip space
- very long operating life
- Removable countersink hole cutter
- fits all electric drills with 13 mm chuck

NEW



Cut hole Ø	68 mm
Depth of cutting hole	55 mm
with countersink hole saw	Yes
Art.-No.	1085-68
Inner packaging/shipping	- / 10



NEW

BASIC cutter

The items in the BASIC series are characterised by their solid cutting quality and long operating life. They are part of the basic equipment for the installation of many KAISER items, especially for creating cut-outs for built-in luminaires or luminaire housings.

- Cutter heads with Bi-Metallic Vario toothing
- with holder and centring drill
- for universal use

BASIC cutter

- with holder and centring drill
- fits all electric drills with 13 mm chuck

NEW



Cut hole Ø	35 mm	74 mm	79 mm	83 mm
Depth of cutting hole	32 mm	32 mm	32 mm	32 mm
For Quickbox Ø 83 mm	-	-	-	Ja
Art.-No.	1084-35	1084-74	1084-79	1084-83
Inner packaging/shipping	- / 1	- / 1	- / 1	- / 10

BASIC cutter Ø 86 mm

- with countersink hole cutter, holder and centering drill
- Removable countersink hole cutter
- fits all electric drills with 13 mm chuck
- for ceiling-flush installation of ThermoX® LED housing (DA 86), Art. No. 9320-20, 9320-21

NEW



BASIC cutter Ø 120 mm

- with holder and centering drill
- fits all electric drills with 13 mm chuck
- for junction boxes Art. No. 9073-01/-78 and 9273-92/-78 as well as installation housing 9273-50

NEW



Cut hole Ø	86 mm	120 mm
Depth of cutting hole	32 mm	32 mm
with countersink hole saw	Yes	-
Art.-No.	1084-86	1084-20
Inner packaging/shipping	- / 1	- / 1

Standard cutter

- without countersink
- with saw blade Art. No. 1086-09
- with twist drill with hexagonal shank



Cut hole Ø	68 mm
Depth of cutting hole	18 mm
Art.-No.	1086-00
Inner packaging/shipping	- / 10

Saw blades

- closed version
- hardened cutting teeth
- for Art. No. 1086-00



Cut hole Ø	35 mm	68 mm	74 mm
Depth of cutting hole	18 mm	18 mm	18 mm
Art.-No.	1085-09	1086-09	1087-09
Inner packaging/shipping	- / 5	- / 5	- / 5

Saw blades

- closed version
- hardened cutting teeth
- for Art. No. 1086-00



Cut hole Ø	68 mm	74 mm
Depth of cutting hole	40 mm	40 mm
Art.-No.	1086-08	1087-08
Inner packaging/shipping	- / 4	- / 4

Twist drill

- with hexagonal shank
- with clamping faces for 18 and 40 mm cutting depths
- for Art. No. 1086-00



Diameter	8 mm
Art.-No.	1086-30
Inner packaging/shipping	- / 5

FLUSH-MOUNTING

CAVITY WALL

CONCRETE

HOUSINGS

FIRE PROTECTION

PLUGGABLE

CONNECTIVITY

CABLE GLANDS

TOOLS

SERVICE



VARIOCUT

VARIOCUT universal hole cutter for clean circular cut-outs in cavity wall and ceiling materials. The hardened metal cutter inserts can cut variable openings with a cutting depth of 45 mm.

- Making clean circular cut-outs using protective cover with dust extractor
- For light installation openings and circular cut-outs Ø 65 - 120 mm in diameter
- Continuously adjustable cutter inserts
- centering cutter aid making it secure to guide the centering drill

Operation



Set and lock required diameter and prescribed cutting depth.



Mark the centre point for drilling (use centering cutter if necessary). Set appropriate speed on electric drill. Pre-drill plates to Ø 6 mm before cutting.



Use VARIOCUT centering drill. Start drilling, push the protective cover down flat on the surface and cut opening applying light pressure.



As soon as a hole has been drilled, turn off the electric drill immediately. Wait until the machine has fully stopped before removing the VARIOCUT and removing the cut-out material.

VARIOCUT universal hole cutter for cavity wall building materials

- with hardened metal cutter inserts for cavity wall materials
- Vacuum cleaner hose attachments from Ø 31 - 36 mm
- including twist drill 6 mm



Cut hole Ø	65 - 120 mm
Depth of cutting hole	45 mm
Art.-No.	1089-00
Inner packaging/shipping	- / 5

Cutter unit for cavity wall building materials

- for VARIOCUT universal hole saw
- for light installation openings and circular cut-outs of any kind



Cut hole Ø	65 - 120 mm
Art.-No.	1089-02
Inner packaging/shipping	- / 1

Cutting unit for metal sheets

- for VARIOCUT universal hole saw
- for sheet thicknesses up to 1 mm
- for light installation openings and circular cut-outs of any kind



Cut hole Ø	61 - 116 mm
Art.-No.	1089-92
Inner packaging/shipping	- / 1

Hardened metal cutter inserts

- For VARIOCUT cutting unit



For cavity wall building materials	Yes	-
For metal sheets	-	Yes
Art.-No.	1089-33	1089-34
Inner packaging/shipping	- / 1	- / 1

Twist drill for VARIOCUT

- for VARIOCUT universal hole saw
- with clamping shank



Diameter	6 mm
Art.-No.	1089-30
Inner packaging/shipping	- / 5

Cutter centering aid

- centering aid for VARIOCUT
- for hard-to-work materials
- for Ø 6 mm drills
- with 10 pieces of adhesive foil



Adhesive foil

- for locating centering aid Art. No. 1089-31
- Double-sided adhesion
- for multiple use



Art.-No.	1089-31	1219-10
Inner packaging/shipping	- / 1	- / 20

FLUSH-MOUNTING

CAVITY WALL

CONCRETE

HOUSINGS

FIRE PROTECTION

PLUGGABLE

CONNECTIVITY

CABLE GLANDS

TOOLS

SERVICE



Universal opening cutter

Universal opening cutter for creating exact openings for cable and conduit entries in plastics. Creating exact openings for boxes and housings always results in exact air-tight, smoke-tight and concrete-tight entries.

- For conduit and cable entries
- For air-tight and smoke-tight openings
- For strain-relieved openings
- For all types of plastic

Operation



Depending on the use, find the required diameter in the corresponding table and locate on tool.



Press snap-in button. Turn the handle and push to required position until the arrow point is visible in the opening. Turn handle back and click into place.



Push the point into the housing and cut out required opening by turning to the right.



TIP: To cut several openings or work with hard plastic, you can fit the opening cutter on the 1/4" bit of a battery-powered drill.

Assignment table for universal cavity wall opening cutter

Air-tight cavity wall installation		Ø setting
NYM cable	3 x 1.5 mm ²	7.5
	4 x 1.5 mm ²	8.5
	5 x 1.5 mm ² ; 3 x 2.5 mm ²	9.5
	7 x 1.5 mm ² ; 5 x 2.5 mm ²	10.5
Low-voltage cables	Integrated heavy current and MSR-Bus cable (N)Y(Y(St)Y)M-J 3 x 1.5 mm ²	10.5
	EDP cable, S/STP 4 x 2 AWG23/1	7.5
	EDP cable, 100 Mb, S/STP 4 x 2 x AWG23/1	6.0
	Coaxial cable, double screening	6.0
	Coaxial cable, single screening	5.0
	BUS cable YCYM 2 x 2 x 0.8	5.0
	Screened EDP cable, plus external screening	5.0
	Cable for telephone and signal transmission with screening	4.0
	Telephone cable without screening	4.0
Support connector	9060-98	Connector
Flexible conduits (crimped) in acc. with DIN EN 60423	DIN EN 16 - Ø 16 mm	14.0
	DIN EN 20 - Ø 20 mm	17.0
	DIN EN 25 - Ø 25 mm	21.0

Cavity wall installation for fire-protection boxes HWD 30, HWD 90 and HWD B15		Ø setting
NYM cable	3 x 1.5 mm ²	8.5
	5 x 1.5 mm ²	9.5
	3 x 2.5 mm ²	9.5

Assignment table for universal concrete construction opening cutter

Concrete construction		Ø setting*
NYY cable	3 x 1.5 mm ²	10.5
	4 x 1.5 mm ²	10.5
	5 x 1.5 mm ² ; 3 x 2.5 mm ²	10.5
	7 x 1.5 mm ² ; 5 x 2.5 mm ²	14.5
Conduits flexible (corrugated) in acc. with DIN EN 60423	DIN EN 20 — Ø 20 mm	19.5
	DIN EN 25 — Ø 25 mm	22.5
Conduits flexible (corrugated with smooth sheath) in acc. with DIN EN 60423	DIN EN 20 — Ø 20 mm	19.0
	DIN EN 25 — Ø 25 mm	22.5

Universal opening cutter for plastics

- for manufacture of exact entry size
- for low-voltage wiring of Ø 4 - 7.5 mm
- for sheathed cabling up to 5 x 2.5 or 7 x 1.5
- for cable NYY up to 5 x 2.5
- for DIN EN conduits (flexible) with outer Ø of up to 20/25 mm
- with 1/4" chuck size for battery-powered drills



For exact openings	4 - 22,5 mm
Art.-No.	1085-80
Inner packaging/shipping	- / 10

AMZ 2 stripping pliers

- for longer cables: integrated knife for longitudinal cutting
- ergonomic design - easy-to-use
- hardened and polished cutting knife



For stripping NYM cables	3 x 1,5, 5 x 2,5 mm
Art.-No.	1190-02
Inner packaging/shipping	- / 10

Examples of use



Using the KAISER stripping pliers, (Art. No. 1190-02), remove the insulation from the cable.

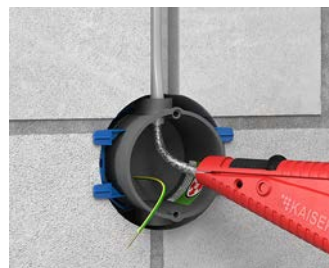

Remove cable sheath and screen with AMZ 2 (Art. No. 1190-02).

Hole punch and expanding dowel fitting tool

- for concrete construction installation
- for fixing to steel formwork with expanding dowel 1217-02
- for all boxes, casings, bushes, etc.



Length	150 mm	340 mm
Art.-No.	1284-62	1284-63
Inner packaging/shipping	- / 1	- / 1

Nail inserter

- for concrete construction installation
- for fixing to wooden formwork with steel nails max. head Ø 4 mm
- for all boxes, casings, bushes, etc.



Length	150 mm	340 mm
Art.-Nr.	1284-69	1284-68
Verpackung innen/Versand	- / 1	- / 1
PG 170 Preis € / 1 ST	108,00	201,00

Punch pliers

- for concrete construction installation
- for exact entries for installation conduits
- with plate ejector
- punch bits exchangeable



DIN EN conduit Ø	20 mm	25 mm
Art.-No.	1286-33	1286-34
Inner packaging/shipping	- / 1	- / 1

Punch bit inserts for punch pliers

- consists of cutter plate and cutting punch, hardened and polished



DIN EN conduit Ø	20 mm	25 mm
Art.-No.	1285-33	1285-34
Inner packaging/shipping	- / 1	- / 1

Reamer

- for concrete construction installation
- for enlarging pre-cut holes



DIN EN conduit Ø	25 mm	32 mm	40 mm
Art.-No.	1284-34	1284-35	1284-36
Inner packaging/shipping	- / 1	- / 1	- / 1

Step drill

- for concrete construction installation
- for manufacturing conduit entry openings
- can be adapted for battery-powered drills



DIN EN conduit Ø	10 - 40 mm
Art.-No.	1284-32
Inner packaging/shipping	- / 10

FLUSH-MOUNTING

CAVITY WALL

CONCRETE

HOUSINGS

FIRE PROTECTION

PLUGGABLE

CONNECTIVITY

CABLE GLANDS

TOOLS

SERVICE



Technical information	405
Number of terminals per box or casing	409
Technical information Connectivity	410
Test mark	412
Item overview	414
New pricing system / Overview of the price groups	421
Item number directory	421
We guarantee quality	429
Endorsements	430
Strong brands for international markets	432
Customer service	434

Conduits and cables

DIN 60423 contains the dimensions for electrical conduits. DIN EN 61386 regulates the designations and properties. This results in clear statements about dimensions, designations and qualities of the conduits. Seven different external diameters are available – uniform for all installation types from flush-mounting to concrete construction: Outside diameters 16, 20, 25, 32, 40, 50 and 63 mm. The following conduit types and cables may be used for the individual construction methods:



Flush-mounting (masonry) construction

Sheathed cables (e.g. NYM, cables e.g. NYY) and multi-lead wiring (e.g. NYIF) in the so-called in-plaster technique in dry rooms are permitted.

In conduits for light construction – classification 2 (min. compressive strength 320 N/5 cm) or higher – , core HO7V cables... (Insulated single wires) and sheathed cables, e.g. NYM, can be guided.



Manufacturer's designation for the conduits, e.g.

Fränkische Rohrwerke:	FBY-EL (flexible) FBY-EL-F (smooth, flexible)
Hegler:	Heglerflex EYL (flexible) Heglerplast EL (rigid)
PIPELIFE:	FB-E-L (flexible) IPM-E-LF (rigid)

Cavity wall construction

Cables without protective conduits whose sheaths are made of flame-retardant plastic, e.g. PVC for sheathed NYM cable are permissible. Multi-lead wiring is not permissible.

In conduits for light construction – classification 2 (min. compressive strength 320 N/5 cm) or higher – as well as additional flame resistance, core HO7V cables... (insulated single wires) as well as sheathed cable, e.g. NYM, can be guided.



Manufacturer's designation for the conduits, e.g.

Fränkische Rohrwerke:	FBY-EL-F (flexible) FFKu-EL-F-HO (flexible)
Hegler:	Heglerflex EYLF (flexible) Heglerflex EL (flexible) Heglerplast-EL (rigid)
PIPELIFE:	FB-E-LF (flexible) KuMS-E-MF (flexible)

Concrete construction

Cables without a protective tube are permissible, e.g. NYY or NYZXY.

Feed-throughs or connections at joints (e.g. wall-ceiling) can only be carried out in the case of stripped core cables or cables in concrete installation boxes or casings only according to DIN

EN 60670. In conduits for a medium construction – classification 3 (min. compressive strength 750 N/5 cm) or higher – , core HO7V cables... (insulated single wires) or sheathed cable, e.g. NYM, can be guided.



Manufacturer's designation for the conduits, e.g.

Fränkische Rohrwerke:	FFKuS-EM-F (flexible) FFKuS-EM-F105 (flexible)
Hegler:	Heglerflex ESPM (flexible) Heglerflex-ESPM105 (flexible) Heglerplast-EPKM (rigid)
PIPELIFE:	Ku-P-AS-E-MF-105 (flexible) RP-E-SF-UV (flexible) KuMS-E-MF (flexible) PSM-v-E-SF (rigid)

As there are currently no specifications in the standard regarding the minimum compressive strength in relation to the type of installation, the conduit manufacturer's specifications must be followed, especially in the concrete construction sector.

Note: The maximum temperature during the casting process for our concrete construction installation boxes with VDE certification is -5 to 90°.



Intelligent building system technology (KNX, LON, etc.)

For the installation of flush-mounting and cavity walls, special one-gang boxes (electronics boxes) are included in the corresponding programme parts.



Disposal

KAISER products are not subject to the electrical/electronic scrap ordinance and are therefore currently not subject to compulsory labelling. For disposal of the packaging, KAISER's trade partners in Germany (electrical wholesalers) offer the installer or end user the option of taking it back (and thus returning it to the cycle).



Fire resistance according to DIN EN 60670

The test is carried out according to DIN EN 60695 S. 2-11. It is carried out as a glow wire test with subsequent test temperatures.

650°C	U	Flush-mounting	
650°C	B	Concrete construction	
650°C	I	In-plaster	
650°C	A	Surface-mounting	
650°C / 850°C		Covers / lids	/
850°C	H	Cavity wall	
850°C	i	Terminals	



Functional integrity of cables / cable systems

Functional integrity is given if no short circuit and no interruption of the current flow in the cable/cable systems occurs in the electrical system during a fire test. The functional integrity is divided into classes from E30-E120 according to DIN 4102 S.12. This means that the installations must withstand a fire for 30-120 minutes. The materials used for such measures must consist of non-combustible building materials (building material class A).



One-gang junction boxes

One-gang junction boxes have, in addition to the accessory volume, space for at least 3 connection terminals. All KAISER one-gang junction boxes may be used as junction boxes when using screwed lids with a fire resistance of 650°/850° C according to DIN EN 60670.



Halogen-free materials (preventive fire protection)

To prevent personal injury or damage to property, the use of halogen-free materials may be mandatory. All KAISER flush-mounting and concrete building boxes, casings, luminaire and loudspeaker housings are halogen-free. Boxes and casings for cavity wall mounting as well as some accessories are included in the range as halogen-free items.

Cavity wall boxes

According to DIN EN 60670, cavity wall boxes are subjected to special safety tests and must be marked with the symbol .



Combinations

Combinations for multiple cover frames of the units are made by stringing together one-gang boxes and/or one-gang junction boxes. The combination distance for this is 71 mm according to DIN 49075.

Combinations of high voltage and low voltage equipment, e.g. antenna sockets, can be shared if only touch-proof sockets are used.

When using sockets that are not safe to touch (still available), a separate cover must be provided for. Usually, the distance between the installation boxes is then 91 mm (more if necessary) and is created by means of distance supports or the use of appropriate tools.



Light hook

Suspension devices for luminaires, e.g. light hooks, must be able to bear at least 50 N according to DIN EN 60670 P. 21 / DIN VDE 0100 P. 559 or the specified luminaire weight with 5-fold safety.



Equipotential bonding

There must be a main equipotential bonding in every building. A so-called additional equipotential bonding must also be carried out according to DIN VDE 0100 P. 701 in rooms with bathtubs or showers, as well as for covered swimming facilities. Due to the easier accessibility for disconnecting and measuring at a later stage, it is expedient to carry out this additional potential equalisation in a corresponding housing with an equipotential bonding busbar. In rooms used for medical purposes, special equipotential bonding must be carried out in accordance with DIN VDE 0100 P. 710.



Plaster protection

According to DIN 18382, protection of the executed service as well as the objects handed over for completing an installation is usually part of the installer's ancillary services. The installation boxes are normally sealed with so-called plaster or signal covers.



Protected areas

For the installation of installation boxes in bathrooms and similar rooms, the requirements according to DIN VDE 0100 S.701 must be observed.

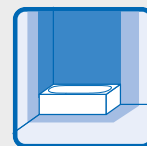

Telephone sockets







According to standard sheet FTZ 731 TR1 issued by Deutsche Bundespost, Fernmeldetechnisches Zentralamt in Darmstadt, only one-gang boxes according to DIN 49073 are approved for the installation of telecommunication inserts.





Environmental compatibility – RoHS

Restriction of the placing on the market and use of certain hazardous substances according to EU Directive 2011/65/EU and EU Directive 76/769/EEC: The materials we use comply with the valid guidelines of the Ordinance on Hazardous Substances and fulfil the legal regulations for placing substances on the market. Emissions during normal use are not known. For more information on RoHS, please visit our website.

	Flush-mounting programme: impact-resistant polystyrene, polyethylene
	Cavity wall programme: Polypropylene
	Concrete construction programme: Polyethylene
	Luminaire and loudspeaker housings programme: Polyethylene/polyamide
	Fire protection programme: galvanised steel sheet, fire-retardant coating
	Cable glands: Polyamide, nickel-plated brass



Wall light connection boxes

According to DIN VDE 0100 S.559, wall light connection boxes must be used wherever feed lines for wall luminaires end. KAISER wall-mounted light connection boxes have space for at least 3 terminal blocks and cable reserves, as well as a screw fastening for luminaire mounting.

For more technical information on our solutions and products, please visit our website.

The installer of the installation system remains responsible for the selecting suitable types of flush-mounting boxes or enclosures and for their proper installation in terms of safety, in compliance with the installation regulations (for an overview of test marks, see table on Pg. 328). The technical advice we provide is given to the best of our knowledge and is deemed to be non-binding, also with regard to any third-party property rights.

Max. number of terminals per one-gang box, one-gang junction box, junction box and junction casing, according to DIN EN 60670. For safety reasons (avoidance of excessive heating in Junction box), according to DIN EN 60670, the number of terminals and conductors in a junction box is limited. A certain volume (terminal space unit) is required for each terminal point. This volume includes the space for the connection terminals, the conductors and the movement of the conductors in the junction box.



Max. number of terminals. Values in () are with mounted

Art. No.	Conductor cross-section (in mm ²)					
	1,5	2,5	4	6	10	16
10...						
1050-00	6	5				
1051-00	6	5				
1055-..	6	5				
1055-26	6 (4)	4				
1056-..	6	5				
1068-02	9 (7)	7 (6)	6 (4)			
1068-21	9 (7)	7 (5)	6 (4)			
1068-25	9 (8)	7 (6)	6 (5)			
1069-02	8(7)	6 (5)				
1081-..	6	6				
1092-..	18	15	12	8	6	5
1094-..	9	7	5			
1095-..	11	9	7	5		
1096-..	18	15	12	8	6	5
1097-..	18	15	12	8	6	5
11...						
1159-90	6	5				
1172-..	6	5				
12...						
1211-01	7 (7)	6 (6)	5 (4)			
1211-02	7	6	5			
1227-50	11	9				
1227-55	10	8				
1245-62	7	5				
1245-63	7	5	4			
1248-..	6	5				
1249-11	5	4				
1249-12	5	3				
1248-55	4	3				
1255-01	6 (5)	5				
1255-43	6	5				
1255-45	6	5				
1260-01	10(8)	8(6)	6(5)			
1260-11	10(8)	8(6)	6(5)			
1262-..	7 (4)	6(5)	5 (4)			
1263-..	8 (7)	6(5)	5 (4)			
1264-60/61	8 (7)	6 (5)	5 (4)			
1265-01	10(8)	8(6)	6(5)			
1265-11	10(8)	8(6)	6(5)			
1265-12	10	8	6			
1265-13	10	8	6			
1268-01	11 (9)	9 (7)	8 (6)			
1269-01	11 (9)	9 (7)	8 (6)			
1276-70	8	6	5			
1295-02	18	15	12	8		
1296-02	18	15	12	8	6	5
1297-02	18	15	12	8	6	5
15...						
1550-..	6 (5)	5 (4)				
1551-..	6 (5)	5 (4)				
1555-..	6 (5)	5 (4)				
1555-26	7 (5)	4				
1555-21	7 (5)	5 (4)				
1556-21	7 (5)	5 (4)				
1556-..	6 (5)	5 (4)				
1572-02	8	6	5			
1569-01	6 (3)	4				
16...						
1656-02	9 (6)	7 (5)				
1656-21	9 (7)	7 (5)	6 (4)			

Art. No.	Conductor cross-section (in mm ²)					
	1,5	2,5	4	6	10	16
90...						
9061-..	5	4				
9062-..	10 (7)	8 (5)	6			
9062-74/94	10 (12)	8 (10)	6 (8)	5 (6)	4 (5)	
9062-21	10	8	6			
9062-94	12 (10)	10 (8)	8 (6)	6 (5)	5 (4)	
9063-..	6	5				
9063-50	6	5				
9064-..	7 (5)	5 (4)				
9064-..	6 (4)	4 (3)				
9068-01/79	6 (3)	5				
9068-04/74	6	5				
9068-03/76	7 (5)	5 (4)				
9068-94	7(7)	6(6)	5(4)			
9069-01	6 (3)	4				
9069-94	6 (5)	5 (4)				
9071-..	7	5				
9073-..	11	9	7			
9074-01	6 (3)	4				
9074-03	6 (3)	4				
91...						
9192-..	18	15	12	8	6	5
9195-..	10	8	6	5		
9196-..	18	15	12	8	6	5
9197-..	18	15	12	8	6	6
92...						
9252-22	9(7)	7(5)	5(4)	4(3)		
9252-78	9(7)	7(5)	5(4)	4(3)		
9253-22	11(9)	9(7)	7(6)	5(4)	4(3)	
9253-78	11(9)	9(7)	7(6)	5(4)	4(3)	
9254-22	14(12)	11(10)	9(8)	6(5)	4(4)	3(3)
9254-78	14(12)	11(10)	9(8)	6(5)	4(4)	3(3)
9263-..	6	5				
9264-..	7 (5)	5 (4)				
9264-05	6 (3)	4				
9264-32	6 (3)	4				
9264-42	6 (3)	4				
9266-22/77	7 (5)	5 (4)				
9268-94/74	7 (7)	6 (6)	5 (4)			
9273-50	12	10				
9273-92/78	12	10	8			
9274-22	6 (3)	4				
9280-22	8(6)	6(5)				
9280-78	8(6)	6(5)				
94...						
9462-94	6 (5)	5 (4)				
9463-01	4	3				
9463-03	6 (3)	5				
9464-01	6 (3)	4				
9464-03	6 (2)	5				
9464-05	6 (3)	5				
9464-15	6 (3)	4				
99...						
9907	17	14	11	7	5	4
9908.01	17	10	11	7	5	4
9908.21	18	15	12	8	6	5
9909.01	12	10	8	5	4	3
9911.01	18	15	12	8	6	5
9912.01	18	15	12	8	6	5
9914.10	18	15	12	8	6	5
9916	18	15	12	8	6	5
9916.21	18	15	12	8	6	5
9917	18	15	12	8	6	5
9917.21	18	15	12	8	6	5

Glass fibres insensitive to bending

are fibre optic cables with a smaller bending radius. While the permissible bending radii of an optical fibre are normally at least 30 mm, the bend-insensitive optical fibre cables according to the ITU-T G.657 specification are 10 mm and 7.5 mm respectively.

ITU-T G.657.A1

(Single mode fibre optic cable) bending radius 10 mm

ITU-T G.657.A2

(Single mode fibre optic cable) bending radius 7.5 mm

FTTX cabling (EN 50173-1)					
Class	Link length	Fibre class	Channel attenuation (dB)		Application
OF-5000	5,000 m	OS2	1310 nm 4.0 dB	1550 nm 4.0 dB	10GBase SR

Factors influencing the transmission rate

The attenuation on the fibre optic cabling route is decisive for the best possible transmission rate of a subscriber's internet connection.

The following factors are decisive:

- possible losses due to scattering or absorption
- natural line losses (length) or signal propagation delay
- losses due to splice connection

Calculation of channel attenuation (single mode fibre 150 m with 3x connectors)				
Description	Attenuation standard	Length Quantity	Calculation	Loss (dB)
Fibre attenuation loss	1.00 dB/km	150 m	0.001 x 150	0.15 dB
Insertion loss per connector	0.25 dB	4	4 x 0.25	1.00 dB
Insertion loss per splice	0.05 dB	3	3 x 0.05	0.15 dB
Total channel attenuation				1.30 dB

The maximum permissible channel attenuation (PoP to FO-SC) of 4.0 dB is not exceeded, therefore, interference-free data transmission can be guaranteed. The calculated channel attenuation must be confirmed and recorded with a certifier (measuring device) after installation of the cabling.

Fibre optic connectors

Fibre optic connectors are mounted on both sides of a fibre optic cable to create a fibre optic patch cable. In addition, the plugs are linked with a connector. The coupling is specially designed for the connectors and positions the end faces (connector end faces) against each other so that the light signal can be transmitted optimally. The connectors are polished after the manufacturing process and protected against dirt and dust with a dust cap. Before using the connectors, the front surface must be cleaned with a cleaning agent (dust-free cloth,

alcohol, cleaning pen, etc.), as the slightest contamination has a great effect on the attenuation.

In the FTTX environment, only connectors with 8° APC (Angular Physical Contact) are used. The front surface is bevelled and polished. The reflections on the fibre optic cable are not transmitted through the connector, thus improving the channel attenuation.

Plug	Max. insertion loss	Typical insertion loss	Ferrules diameter	Number of fibres	Standard	Locking
SC	0.25 dB	0.15 dB	2.50 mm	1	IEC 61754-4	Draw/Plug
LC	0.25 dB	0.15 dB	1.25 mm	1	IEC 61754-20	Clamping bracket
E2000®	0.25 dB	0.12 dB	2.50 mm	1	IEC 61754-15	Draw/Plug
E3S Connect®	0.25 dB	0.15 dB	1.25 mm	1	IEC 61754-20*	Clamping bracket

(Test method IEC 61300-3-34; guarantees a maximum insertion loss of 0.25 dB when using Grade B connectors)

*E3S Connect® connector becomes standard LC/APC connector after assembly with housing and locking housing

Fibre recognition

The fibre optic categories and connectors are differentiated by colour. This means that the colour code can be used to draw immediate conclusions about the installed system.

Category	Connectors	Patch cables
OS2 Single Mode	Blue	Yellow
OS2 Single Mode APC	Green	Yellow

Splice detection

The individual fibre optic lines in a fibre optic cable are defined by standard to simplify processing during splicing. In Germany, DIN IEC 60304 and DIN VDE 0888 applies; outside Germany, IEC 60794- 2 and TIA 598-B are also applicable.

Depending on the network operator and project (subsidised project), an up to 4x fibre optic cable per subscriber is laid for FTTH cabling. In an apartment building or larger residential complex, 2x fibre optic cables must also be provided for the building. Usually the fibre colour code 1-4 (red, green, blue and yellow) is used per subscriber, as the connection/customer cables have the same colour coding, so a clean and structured splice work is ensured.

Colour code (VDE-0888)					
1		Red	7		Brown
2		Green	8		Violette
3		Blue	9		Aqua
4		Yellow	10		Black
5		White	11		Orange
6		Grey	12		Pink















KAISER GROUP - General Glossary





Network level 1	Wide area network
Network level 2	Regional distribution network
Network level 3	Access network
Network level 4	Building network
Network level 5	Unit network
Broadband	In communications engineering, the term broadband communication describes a transmission channel whose magnitude frequency response is not constant and in which signal distortions occur as a result. Wideband channels, unlike narrowband channels, require channel equalization with adaptive filters to compensate for signal distortion.
DSL	The end customer is connected to the telecommunications network exclusively on a copper basis. In this case, the telecommunications cable runs from the main distribution frame (MDF) to the cable distribution frame (CDF) and from there to the house connection.
Vectoring	Vectoring technology is an extension of VDSL2; with the help of vectoring the crosstalk (NEXT) between the individual wires in the copper telecommunication cable can be minimized, and the transmission speed as well as the number of connected subscribers around a CDF can be increased.
FTTX	Fibre to the "X", in the case of fibre optic networks, a distinction is made between the types of connection depending on how the end customer is connected, between FTTC (Fibre to the Curb), FTTB (Fibre to the Building) and FTTH (Fibre to the Home).
HFC	Hybrid Fibre Coax is used by cable network operators to connect cable television networks (CATV) via fibre optic cable from the cable head-end (exchange) to the end branch (fibre node). The data signals are transmitted from the end splitter to the antenna socket in the house via coaxial cable.
FTTC	Fibre to the Curb; the fibre optic line is only laid to the cable distribution frame (CDF)/multifunctional housing (MFH), (integrated DSLAM (Digital Subscriber Line Access Multiplexer) at the roadside. From there, the existing copper telecommunication cables (Cu-DA) of the distribution network lead to the end customer.
FTTB	Fibre to the Building; in contrast to FTTC/VDSL, FTTB/FTTH networks consist entirely of a fibre optic infrastructure. The fibre optic line extends from the exchange (PoP) via the network distributor (FO-ND) to the house transfer point (HTP).
FTTH	Fibre to the Home; with FTTH, the entire cabling in the building up to the FO-SC also consists of fibre optic lines.
PoP	Point of Presence, different designation for the switching station
FO-ND	The fibre optic network distributor is a passive distributor for cable distribution of fibre optic communication lines within a local network
Supply sleeve	The sleeve is a passive distribution box for cable distribution of fibre optic communication lines within a local area network
FTU	Fibre Termination Unit
FO-TP / BTP	The fibre optic termination point of the network operator, other designation Building Transfer Point, other designation BEP (Building Entry Point)
FO-BD	Fibre optic building distributor, different designation PD (primary distributor)
FO-FD	THE fibre optic floor distributor, different designation FO-CP (fibre optic collection point)
FO-SC	The fibre optic subscriber connection, different designation fibre optic subscriber outlet





KAISER GROUP - Product Glossary

FMP	Splice distributor housing (fibre management plate)
FMB	Splice distributor housing with cover (fibre management box)
MFD	Hood sleeve (midi fibre dome)
CFD	Repair sleeve (compact fibre dome)
DP	"Distribution Point" is a distribution point between PoP and BTP, e.g. supply sleeve (underground) or FO-ND (above ground)

KAISER products are manufactured according to DIN, VDE, EN and IEC regulations. For the products shown in the catalogue, we have, as far as regulations exist, approval certificates from the VDE test centre as well as a number of other European test centres.

	Germany	VDE ASSOCIATION OF ELECTRICAL ENGINEERING ELECTRONICS INFORMATION TECHNOLOGY	
	Austria	AUSTRIAN ASSOCIATION FOR ELECTRICAL ENGINEERING	
	Belgium	COMITE ELECTROTECHNIQUE BELGE asbl	
	Czech republic	ELEKTROTECHNICKÝ ZKUŠEBNÍ ÚSTAV	
	Hungary	MAGYAR ELÉKTROTECHNIKAI ELLENŐRZŐ INTÉZET	
	Slovenia	SLOVENSKI INSTITUT ZA KAKOVOST IN MEROSLOVJE	
	Switzerland	ASSOCIATION FOR ELECTRICAL, ENERGY AND INFORMATION TECHNOLOGY	
	Great Britain	BRITISH STANDARD	BS

Art. No.						BS
10...						
1048-00	•					
1050/51	•					
1055-04	•					
1055-21	•					
1055-62	•					
1056-04	•					
1056-21	•					
1056-62	•					
1068-02	•					
1068-21	•					
1068-26	•					
1069-02	•					
1075-04	•					
1076-04						
1076-20		•				
1081-04	•					
1081-05	•					
1081-06	•					
1092-90	•					
1094-01						
1094-91	•					
1095-01						
1095-91	•					
1096-01						
1096-91	•					
1097-75						
1097-92	•					
11...						
1155-61						
1155-62						
1155-71						
1155-72						
1159-03						
1159-12						
1159-24						
1159-34						
1159-50						
1159-55	•					
1159-90	•					
1172-02						
1172-04						
1172-05						
1172-06						
1172-08						
1172-09	•					
1172-62	•					
1172-92	•					
12...						
1204-24						
1204-29						
1204-34						
1211-01	•					
1211-02	•					

Art. No.						BS
1223						•
1224						•
1227-16	•					
1227-50	•					
1227-54	•					
1227-55	•					
1245-	•					
1248-01	•	•		•		
1248-44						
1248-55	•					
1249-11 / 12	•	•				
1249-44						
1255-43						
1255-45						
1260-01	•	•		•		
1262-06	•	•				
1262-60	•	•				
1262-61	•	•				
1263-06	•	•				
1263-60	•	•				
1263-61	•	•				
1264-06	•	•				
1264-60	•	•				
1264-61	•	•				
1265-11	•	•				
1268-	•	•		•		
1269-	•	•		•		
1275-40						
1276-40						
1276-70						
1295-02	•					
1295-73						
1296-02	•					
1297-02	•					
1297-75						
1297-98						
15...						
1550-00	•					
1551-00	•					
1555-04	•					
1555-21	•					
1555-51	•					
1555-62	•					
1556-04	•					
1556-21	•					
1556-62	•					
1564-01	•					
1569-01	•					
1572-02	•					
16...						
1655-02	•					
1656-02	•					
1656-21	•					
1656-26	•					

Art. No.							BS
25...							
2521	•						
90...							
9061-00							
9061-01	•						
9061-78	•						
9062-02	•			•			
9062-74				•			
9062-77				•			
9062-94	•						
9063-02	•			•			
9063-50	•						
9063-78	•			•			
9064-02	•			•			
9064-78	•			•			
9066-01	•			•			
9066-12	•			•			
9066-77	•						
9067-01	•			•			
9068-01	•						
9068-03	•			•			
9068-04	•						
9068-74	•						
9068-76	•			•			
9068-79	•						
9068-94	•			•			
9069-01	•						
9069-03	•			•			
9069-04	•			•			
9069-74	•						
9069-75	•			•			
9069-76	•			•			
9069-77	•						
9069-94	•						
9071-01	•						
9071-77	•						
9073-01	•						
9073-78	•						
9074-01	•						
9074-03	•						
9075-01	•						
9075-12	•						
9075-77	•						
9075-78	•						
9098-02							
9098-77							
9098-77						•	
91...							
9148-00	•			•			
9192-77	•						
9192-91	•			•			
9195-73							
9195-77	•			•			
9195-91	•			•			
9196-77	•						
9196-91	•			•			
9197-77	•			•			
9197-91	•			•			
92...							
9248-01							
9252-	•						
9253-	•						
9254-	•						
9263-22	•			•			
9263-78	•						
9264-12	•			•			
9264-22	•			•			
9264-72	•			•			

Art. No.							BS
9264-78	•						
9266-22	•						
9266-77	•						
9268-74	•			•			
9268-94	•			•			
9273-78	•						
9273-92	•						
9274-22	•						
9280-22	•			•			
9280-78	•			•			
93...							
9300-01							
9300-02							
9300-03							
9310-10							
94...							
9435-01							
9461-14			•				
9461-15			•				
9462-94	•						
9463-01	•						
9463-03	•						
9463-14			•				
9463-15			•				
9463-50	•						
9464-01	•						
9464-03	•						
9464-05	•						
9464-14			•				
9464-15			•				
9464-50	•						
9498-77						•	
9499-77						•	
97...							
9798-77						•	
9799-77						•	
99...							
9966.21						•	
9966.22						•	
AT...							
AT2218	•						
AT2219	•						
AT2229	•						
AT2234	•						
AT2238	•						
AT2239	•						
AT2250	•						
AT2251	•						
AT2252	•						
AT2258	•						
AT2274	•						
AT2275	•						
AT2276	•						
AT2277	•						
AT2278	•						
AT2280	•						
AT2281	•						
AT2289	•						
AT2290	•						
AT2292	•						
AT2293	•						
AT2297	•						
AT2304	•						
AT2306	•						
AT2500	•						
AT2502	•						

FLUSH-MOUNTING

CAVITY WALL

CONCRETE

HOUSINGS

FIRE PROTECTION

PLUGGABLE

CONNECTIVITY

CABLE GLANDS

TOOLS

SERVICE

1-9			
100 mm slab ceiling box for retrofitting	180		
115 large slab ceiling box	179		
30° Ø 20 mm wall and ceiling transition	233		
30° Ø 25 mm wall and ceiling transition	233		
30° Ø 32 mm wall and ceiling transition	233		
48.5 mm extension element for system magnet	222		
60° conduit connector	220		
90° Ø 20 mm wall and ceiling transition	121/233		
90° Ø 25 mm wall and ceiling transition	121/233		
90° Ø 32 mm wall and ceiling transition	233		
A			
Abutment	173		
Abutment for adhesive foil	173		
Abutment without special adhesive	223		
Adapter C, Keystone type	315		
Adapter CL, Keystone type with label window	315		
Adhesive foil	399		
Adhesive foil, double-sided adhesive	171		
Air-tight sleeves for cables	124		
Air-tight sleeves for conduits	124		
AK2 Data basic housing with angled mounting plate	314		
AK2 Data basic housing with flat mounting plate	314		
AK2 Data basic housing with hole grid fixing	314		
AK2 Data basic housing with screw holes fixing	314		
AK2 Data basic housing with screw lugs	314		
AK2 Data front part for max. 4 modules	315		
AK2 Data front part for max. 6 modules	315		
AK2 Mounting cover IP40 light grey	313		
AK2-C2 Cover with integrated duplex outlet green	313		
AK2-C2 Cover with integrated duplex outlet light grey	313		
AK2-C2 Cover with integrated duplex outlet red	313		
AK2-C2 Cover with integrated fourplex outlet green	313		
AK2-C2 Cover with integrated fourplex outlet red	313		
AK2-C4 Cover with integrated fourplex outlet light grey	313		
AK2-CD Onderbak centraaldoos	309		
AK2-S enclosure base IP40	309		
AK2-S Flat mounting plate	310		
AK2-S/GZ IP40	309		
AK2-S/MD cable box for mesh cable trays	308		
AK2-S/MK Cable box cable duct	308		
AK2-S/VK IP40	309		
AK2-SU enclosure base IP40	308		
AK2-W5 Cover green	312		
AK2-W5 Cover light grey	312		
AK2-W5 Cover red	312		
AK2-W5 Cover yellow	312		
AK2-W8 Cover green	312		
AK2-W8 Cover light grey	312		
AK2-W8 Cover red	312		
AK2-W8 Cover yellow	312		
AK2-W8 Cover, 2x3p WIELAND	310		
AK2-W8 Cover, 3x3p Wieland	310		
AK2-W8 Cover, 4x3p Wieland	310		
AK2-W8 Cover, 6x3p Wieland	310		
AK2-WA8 Cover, 2x3p WAGO	310		
AK2-WA8 Cover, 3x3p WAGO	310		
AK2-WA8 Cover, 4x3p WAGO	310		
AK2-WA8 Cover, 6x3p WAGO	310		
Aluminium-butyl sealing sleeve	128		
Aluminium-butyl sealing sleeve, Ø 12 – 15 mm	128		
AMZ 2 stripping pliers			401
B			
B ¹ 35 mm diameter ceiling junction box			177
B ¹ 45° - Ø 35 mm domed box			177
B ¹ 45° - Ø 60 mm domed box			177
B ¹ 45° universal ceiling exit			178
B ¹ 60 mm diameter ceiling junction box			177
B ¹ electronics box			166
B ¹ large conduit ceiling junction box - Ø 60 mm			178
B ¹ large conduit one-gang junction box			162
B ¹ one-gang box			161
B ¹ one-gang box Italian standard with 3 modules			201
B ¹ one-gang box Italian standard with 4 modules			201
B ¹ one-gang junction box			161
B ¹ Prefix® system wing bracket set		167/187	
B ¹ Prefix® wall outlet adapter		186/187	
B ¹ Two-gang junction box			166
B ¹ universal ceiling exit - Ø 45 mm			179
B ¹ universal wall exit			163
B ¹ wall light connection box			162
B15 PROTECT® cable sealing			293
B15 PROTECT® multiple sealing			293
B ² one-gang junction box for system magnet, depth 48.5 mm			215
B ² one-gang junction box for system magnet, depth 68.5 mm			215
B ² one-gang junction box for system magnet, depth 83.5 mm			215
B ² one-gang junction box with plaster skin, depth 48.5 mm			216
B ² one-gang junction box with plaster skin, depth 68.5 mm			216
B ² one-gang junction box with plaster skin, depth 83.5 mm			216
B ² one-gang junction box without plaster skin, depth 48.5 mm			215
B ² one-gang junction box without plaster skin, depth 68.5 mm			215
B ² one-gang junction box without plaster skin, depth 83.5 mm			215
BASIC cutter Ø 120 mm			396
BASIC cutter Ø 35 mm with holder and centring drill			396
BASIC cutter Ø 74 mm with holder and centring drill			396
BASIC cutter Ø 79 mm with holder and centring drill			396
BASIC cutter Ø 83 mm with holder and centring drill		154/396	
BASIC cutter Ø 86 mm			396
Blanking plug			315
Box sealing system DS 90 / 120 mm			299
Box sealing system DS 90 / 74 mm			298
C			
Cable glands Syntec® nickel-plated brass with lamellar technology			365
Cable sealing system LS 90			297
Cable-sleeve ECON®			126
Cavity wall box template			394
Cavity wall one-gang junction box			112
Cavity wall one-gang junction box without support, Depth 63 mm			35
Cavity wall one-gang junction box without support, with device screws, Depth 63 mm			35
Ceiling box HWD 30			289

Ceiling exit bush	38	Diamond grinding head without dust extraction	380
Ceiling exit bush with light hook and expanding dowel	38	Direct attachment	380
Ceiling junction box HWD 30	289	Distance cutter, Profix	394
Ceiling penetration sealing system DS 90 / 120 mm	301	Distance piece 142	216
Ceiling penetration sealing system DS 90 / 74 mm	300	Distance piece 91	166
Ceiling strip (ceiling exit)	188	Distance supports	46
Centering aid Ø 68 mm	385	Drilling template	381
Centering drill	380	Dust extraction for cavity wall cutters	393
Centering drill Ø 6x75 mm for PROFI and EXPERT cutter heads	389	Dust extraction with chuck attachment	379
Centering insert 68/74	387	Dust extraction with direct attachment	379
Central transition casing for universal conduit entries 191/230		E	
Chuck attachment	380	E3S Connect® (FO-SC) subscriber connection, flush-mounting, 2xF, LC/APC QD, FO-BD	333
Clean room one-gang junction box with peripheral sealing lip, depth 62 mm	137	E3S Connect® (FO-SC) subscriber connection, flush-mounting, 2xF, LC/APC QD, HTP	330
Collet Ø 10 mm for PROFI and EXPERT cutter heads, connection thread 5/8"	389	E3S Connect® (FO-SC) subscriber connection, flush-mounting, 4xF, LC/APC QD, FO-BD	332
Collet Ø 12 mm for PROFI and EXPERT cutter heads, connection thread 5/8"	389	E3S Connect® (FO-SC) subscriber connection, flush-mounting, 4xF, LC/APC QD, HTP	329
Combination one-gang box	71	E3S Connect® (FO-SC) subscriber connection, surface-mounting, 2xF, LC/APC DX, FO-BD	327
Compact building distributor, Gf-GV, 20 fibres, CSP, 5 LC/APC QD, IP55	357	E3S Connect® (FO-SC) subscriber connection, surface-mounting, 2xF, LC/APC DX, HTP	324
Compact building distributor, Gf-GV, 24 fibres, CSP, 6 LC/APC QD, IP55	357	E3S Connect® (FO-SC) subscriber connection, surface-mounting, 4xF, LC/APC DX, FO-BD	326
Compact building distributor, Gf-GV, 4 fibres, CSP, 1 LC/APC QD, IP55	357	E3S Connect® (FO-SC) subscriber connection, surface-mounting, 4xF, LC/APC DX, HTP	323
Compensation ring from Ø 74 mm to Ø 68 mm	96	E3S Connect® accessory box	338
Compensation ring up to max. Ø 71 mm	96	E3S Connect® building distributor	335
Conduit and cable distance piece	207	E3S Connect® E3S-E3S system cable, 2xF, FO-BD to FO-FD	337
Conduit and cable distance support	207	E3S Connect® LC/APC-E3S fibre-optic patch cable, 2xF, HTP to FO-BD	334
Conduit bend support	189	E3S Connect® patch cassette, set of 4	336
Conduit connector 90° for DIN EN conduit Ø 20 mm	220	ECON® Iso + / ECON® Styro 55 setting tool	385
Conduit connector 90° for DIN EN conduit Ø 25 mm	220	Ejector spring for PROFI and EXPERT cutter heads	389
Conduit connector 90° for DIN EN conduit Ø 32 mm	220	Electronic box with partition and cover, airtight, depth 75 mm	93/114
Conduit connector for DIN EN conduit Ø 20 mm	218	Electronic box with partition and cover, airtight, depth 75 mm, halogen-free	93/114
Conduit connector for DIN EN conduit Ø 25 mm	218	Electronics box ECON®, airtight	30
Conduit connector for DIN EN conduit Ø 32 mm	218	Electronics box HWD 90	283
Conduit connector for DIN EN conduit Ø 40 mm	218	Electronics box O-range ECON® Flex, air-tight, Depth 75 mm	109
Conduit sealing cap	189	Electronics box O-range ECON® Flex, air-tight, Depth 75 mm, halogen-free	109
Conduit sealing system RS 90	297	Electronics box with separator wall	26
Conduit support	189	End and transition grommet	185
Conduit transition coupling Ø 32 mm	219	End and transition grommet Ø 20 mm	184
Conduit-sleeve ECON®	126	End and transition grommet Ø 25 mm	184
Connecting clip for stacking boxes 9062-02/-77	94	End and transition grommet Ø 32 mm	184
Cover	115/206	End and transition grommet, Ø 20 mm	232
Cover 75 x 40 mm	38/94	End and transition grommet, Ø 25 mm	232
Cover for boxes Ø 60 mm	48	End and transition grommet, Ø 32 mm	232
Cover for boxes Ø 70 mm	48	End cover	51/149/205
Cover for boxes Ø 80 mm	48	EnoX® luminaire and loudspeaker housing	269
Cover with cable entry	206	EnoX® sealing foam frame	269
Cutter centering aid	399	Equipotential bonding casing 10 ²	169
Cutter unit for cavity wall building materials	398	Equipotential bonding casing 16 ²	169
Cutting unit for metal sheets	399	Expanding dowel	207/240
D		EXPERT carbide countersink hole cutter Ø 68 mm for flush-mounting box installation	389
Damp room one-gang junction box	145		
Data cable entry	315		
Device screw +/-, Length 15 mm	48/146		
Device screw +/-, Length 20 mm	48/146		
Device screw +/-, Length 40 mm	48/146		
Device screws +/-, Length 25 mm	48/146		
Diamond grinding head with dust extraction	379		

FLUSH-MOUNTING

CAVITY WALL

CONCRETE

HOUSINGS

FIRE PROTECTION

PLUGGABLE

CONNECTIVITY

CABLE GLANDS

TOOLS

SERVICE

Service

Item overview

EXPERT carbide countersink hole cutter Ø 74 mm for flush-mounting box installation	389	HaloX® 100 with tunnel 190 for on-site mixed concrete	249
EXPERT carbide cutter head Ø 68 mm with ejector spring	389	HaloX® 100 front parts, square for facing concrete	251
EXPERT carbide cutter head Ø 68 mm without ejector spring	389	HaloX® 180 for on-site mixed concrete	249
EXPERT carbide cutter head Ø 74 mm with ejector spring	389	HaloX® 180 for precast concrete	262
EXPERT carbide cutter head Ø 74 mm without ejector spring	389	HaloX® 180 for precast concrete for magnet attachment	263
EXPERT carbide cutter Ø 68 mm with countersink hole cutter and holder for centering drill	388	HaloX® 180 front parts	252
EXPERT carbide cutter Ø 74 mm with countersink hole cutter and holder for centering drill	388	HaloX® 180 front parts for facing concrete	252
Extension element 10/50 mm	223	HaloX® 180 universal front parts	252
Extension element for ThermoX® Iso +	68	HaloX® 180 with tunnel 190 for on-site mixed concrete	249
Extension element for universal equipment carrier	59/61	HaloX® 180 with tunnel 190 for precast concrete	262
Extension piece - 12mm - for junction box 9907/9907.21	170	HaloX® 180 with tunnel 325 for on-site mixed concrete	249
Extension piece - 13mm - for junction box	83/170	HaloX® 180 with tunnel 325 for precast concrete	262
Extension piece - 45mm - for flush-mounted junction box 9907/9907.21	170	HaloX® 180 with tunnel for precast concrete for magnet attachment	263
Extension piece - 45mm - for junction box	83	HaloX® 250 for on-site mixed concrete	249
Extension pieces for extra-large flush-mounted junction boxes	194	HaloX® 250 for precast concrete	262
Extension rings HaloX®	254/259/265	HaloX® 250 for precast concrete for magnet attachment	263
Extra-large flush-mounted junction boxes	192/193	HaloX® 250 front parts	253
Extra-large flush-mounted junction boxes	193	HaloX® 250 front parts for facing concrete	253
F		HaloX® 250 universal front parts	253
Fire-protection cover HWD 30-120	289	HaloX® 250 with tunnel 325 for on-site mixed concrete	249
Fire-stop box FlamoX®	303	HaloX® 250 with tunnel 325 for precast concrete	262
Fixing adapter for internal insulation box	57	HaloX® 250 with tunnel for precast concrete for magnet attachment	263
Fixing and support element Flat 45/120	240	HaloX® housing for drilling holes in solid ceilings	259
Fixing and support element Flat 45/80	240	Hardened metal cutter insert for VARIOCUT	399
FlamoX® fire-protection putty	281	Hole punch and expanding dowel fitting tool	402
Fleece-butyl sealing sleeve	127	HWD 68+ one-gang box	285
Fleece-butyl sealing sleeve, Ø 12 – 15 mm	127	HWD 68+ one-gang junction box	285
Flush mounted combination box „The green one“	82	HWD 90 one-gang box	282
Flush mounting one-gang junction box, Depth 66 mm	25	HWD 90 one-gang junction box	282
Flush-mounted junction box - 101mm	169	HWD B15 one-gang box for thin boarding	291
Flush-mounted junction box - 105mm - for flexible corrugated plastic conduits (KRFG)	170	HWD B15 one-gang junction box for thin boarding	292
Flush-mounted junction box - 150mm	169	I	
Flush-mounted junction box - 150mm - for flexible corrugated plastic conduits (KRFG)	170	In-plaster junction box for flat multi-lead wiring (NYIF), with terminal block, 5 poles	37
Flush-mounted junction box - 76mm	169	In-wall back box 115 x 115 x 101 mm, quadratic glow wire tested 850°C	82
Flush-mounted junction box - Type 1	192	In-wall back box 115 x 115 x 76 mm, quadratic glow wire tested 850°C	82
Flush-mounted junction box - Type 2	192	Inlet casing 1x1	202
Flush-mounting fire-protection box	278	Inlet casing 2x1	202
Flush-mounting gun foam	23	Inlet casing 2x2	203
Flush-mounting sound insulation one-gang junction box	41	Inlet casing 3x1	202
Formwork body for DS 90 / 120 mm	301	Inlet casing 3x2	203
Formwork body for DS 90 / 74 mm	301	Inlet casing 3x3	203
Formwork protector	188/189	Inlet casing 4x1	202
H		Inlet casing 4x2	203
halogen-free sound insulation box	131	Installation housing O-range ECON® Universal 120, air-tight, Depth 65 mm	106
HaloX® 100 for on-site mixed concrete	249	Installation housing ThermoX® Iso +	68
HaloX® 100 front parts	250	Installation set for wall installation	254
HaloX® 100 front parts for facing concrete	250	Insulated hook screw, 100 mm	182
HaloX® 100 front parts, square	251	Insulated hook screw, 120 mm	182
HaloX® 100 installation kit	258	Insulated hook screw, 140 mm	182
HaloX® 100 Multi-conduit entry	250	Insulated hook screw, 30 mm	182
HaloX® 100 universal front parts	251	Insulated hook screw, 40 mm	182
		Insulated hook screw, 60 mm	182
		Insulated hook screw, 80 mm	182
		Interior Insulation box for insulation thicknesses 30 - 100 mm	57

Intermediate frame	254/258/259
IP68BOX Outdoor Installation Set	317
J	
Junction box	164
Junction box for KLEMMFIX® mounting	36
Junction box for KLEMMFIX® mounting, with cover and 2 cover screws	36
Junction box for nailing, Depth 36 mm	36
Junction box Ø 120 mm	148
Junction box Ø 120 mm O-range ECON®, air-tight, Depth 65 mm	104
Junction box Ø 120 mm O-range ECON®, air-tight, Depth 65 mm, halogen-free	104
Junction box with plaster disc and cover	37
Junction box with universal VDE cover, Depth 50 mm	90
Junction box with universal VDE cover, Depth 50 mm, halogen-free	90
Junction box, Depth 56 mm	37
Junction casing 105 x 105 x 53 mm	147
Junction casing 128 x 128 x 80 mm	168/201
Junction casing 165 x 165 x 72 mm	147
Junction casing 180 x 180 x 84 mm	168
Junction casing 235 x 205 x 72 mm	148
Junction casing 240 x 140 x 72 mm	148
Junction casing 250 x 220 x 82 mm	168
Junction casing with cover, 107 x 107 x 57 mm	50
Junction casing with cover, 107 x 107 x 57 mm, halogen-free	50
Junction casing with cover, 159 x 159 x 75 mm	50
Junction casing with cover, 159 x 159 x 75 mm, halogen-free	50
Junction casing with cover, 238 x 208 x 68 mm, halogen-free	50
Junction casing with cover, 240 x 142 x 87 mm, halogen-free	50
Junction casing with cover, 87 x 87 x 60 mm	49
Junction casing with cover, 87 x 87 x 60 mm, halogen-free	49
K	
KBS Slide-in entry Ø 16 mm	309
KLEMMFIX® for junction boxes	45
KLEMMFIX® for one-gang and one-gang junction boxes	45
L	
Lamp box with outlet Ø 35 mm	182
Lamp box with outlet Ø 60 mm	182
Lamp box with perforated collar Ø 85 mm	181
Lamp box, outlet 35x35 mm	183
Lamp box, outlet Ø 30 mm	182
Large slab ceiling box 105	227
Large slab ceiling box 115	226/227
Light hook	180
Light hook with thread M5, shaft length 105 mm	180/227
Light hook with thread M5, shaft length 115 mm	180/227
Light hook with thread M5, shaft length 125 mm	180/227
Light hook, 55 mm	95/180
Light hook, 65 mm	95/180
Lock nuts nickel-plated brass	369
Locking plug nickel-plated brass	369
Luminaire connection box	38
Luminaire connection box, Depth 47 mm	95

M	
Magnet	213/240
Marking chalk	381
MD Mounting plate for mesh cable trays	310
MD-CD100R centre ceiling box	241
MD-CD80R centre ceiling box	241
Metal lugs for screws	146
Mini equipment carrier with 4 swivels and 2 ribs	74
Moisture-proof cover ALU (330 x 120 x 8 mm) for Art. No. 9914.10	191/230
MontaX - Magnet	375
MontaX mounting plate	374
Mounting angle for MontaX	375
Mounting plate MK for cable trays	310
N	
Nail inserter	402
O	
O-range ECON® 2 one-gang junction box, air-tight, Depth 48 mm	101
O-range ECON® 2 one-gang junction box, air-tight, Depth 48 mm, halogen-free	101
O-range ECON® 3 one-gang junction box, air-tight, Depth 48 mm	101
O-range ECON® 3 one-gang junction box, air-tight, Depth 48 mm, halogen-free	101
O-range ECON® 4 one-gang junction box, air-tight, Depth 48 mm	102
O-range ECON® 4 one-gang junction box, air-tight, Depth 48 mm, halogen-free	102
O-range ECON® 63 one-gang box, air-tight, Depth 49 mm	99
O-range ECON® 63 one-gang box, air-tight, Depth 49 mm, halogen-free	99
O-range ECON® 64 one-gang junction box, air-tight, Depth 62 mm	99
O-range ECON® 64 one-gang junction box, air-tight, Depth 62 mm, halogen-free	99
O-range ECON® conduit one-gang junction box, air-tight, Depth 62 mm	103
O-range ECON® conduit one-gang junction box, air-tight, Depth 62 mm, halogen-free	103
O-range ECON® Data one-gang connection box, air-tight, Depth 74 mm, halogen-free	111
O-range ECON® Data one-gang connection box, air-tight, étanche à l'air, Depth 74 mm	111
O-range ECON® Fix one-gang junction box, air-tight, Depth 62 mm	108
O-range ECON® Fix one-gang junction box, air-tight, Depth 62 mm, halogen-free	108
O-range® one-gang box for thin boardings, depth 35 mm	91
O-range® one-gang box for thin panelling, depth 35 mm, halogen-free	91
O-range® one-gang box, Depth 49 mm	88
O-range® one-gang box, Depth 49 mm, halogen-free	88
O-range® one-gang junction box, Depth 62 mm	88
O-range® one-gang junction box, Depth 62 mm, halogen-free	88
O-range® Protect ³ one-gang box	304
O-range® Protect ³ one-gang junction box	304
O-range® separator	102
One place back box „the blue one“ 59 mm	81
One-gang box	163

FLUSH-MOUNTING

CAVITY WALL

CONCRETE

HOUSINGS

FIRE PROTECTION

PLUGGABLE

CONNECTIVITY

CABLE GLANDS

TOOLS

SERVICE

One-gang box (Italian and American standard), 100 x 60 x 52 mm	83	Optical termination outlet (OTO), unequipped	344
One-gang box (Italian and American standard), 121 x 60 x 52 mm	83	Oval funnel for M20 conduits	237
One-gang box acc. to EN 60670 and ÖVE	83	Oval funnel for M25 conduits	237
One-gang box CEE	113/164	P	
One-gang box CEE with sealing ring, Depth 50 mm	90	Plaster compensation ring	216
One-gang box CEE with sealing ring, Depth 50 mm, halogen-free	90	Plaster compensation ring for boxes Ø 68 mm, Height 10 mm	96
One-gang box CEE, Depth 50 mm	35	Plaster compensation ring for boxes Ø 68 mm, Height 20 mm	96
One-gang box CEE, halogenfree	113	Plaster compensation ring for boxes Ø 74 mm, Height 12 mm	96
One-gang box ECON® 10, air-tight, Depth 46 mm	28	Plaster compensation ring for boxes Ø 74 mm, Height 24 mm	96
One-gang box ECON® 10, air-tight, with device screws, Depth 46 mm	28	Plaster compensation ring for junction boxes Ø 70 mm, Height 12 mm	47
One-gang box Flat 45	239	Plaster compensation ring for junction boxes Ø 70 mm, Height 24 mm	47
One-gang box for British accessories, one-gang	200	Plaster compensation ring for one-gang and one-gang junction boxes Ø 60 mm, Height 12 mm	47
One-gang box for British accessories, two-gang	200	Plaster compensation ring for one-gang and one-gang junction boxes Ø 60 mm, Height 24 mm	47
One-gang box for Italian and American accessories	201	Plastering covers	194
One-gang box for nailing, Depth 42 mm	34	Plug-in cover Ø 35 mm	207
One-gang box for nailing, with device screws, Depth 42 mm	34	Pluggable AK2 front part, WAGO WINSTA® MIDI, out: 2x5pin DALI blue	316
One-gang box for PERILEX®	164	Pluggable AK2 front part, WAGO WINSTA® MIDI, out: 3x5pin DALI blue	316
One-gang box for thin boardings	112	Pluggable AK2 front part, WAGO WINSTA® MIDI, out: 4x5pin DALI blue	316
One-gang box for thin boardings, depth 41 mm	92	Pluggable AK2 front part, Wieland GST18, out: 2x5pin DALI blue	316
One-gang box for thin panelling, depth 41 mm, halogen-free	92	Pluggable AK2 front part, Wieland GST18, out: 3x5pin DALI blue	316
One-gang box HWD B15	291	Pluggable AK2 front part, Wieland GST18, out: 4x5pin DALI blue	316
One-gang box HWD B15 for thin boarding 40 mm	291	Potential equalisation casing 10 ²	149
One-gang box PERILEX®, Depth 48 mm	35	Potential equalisation casing 10 ² with cover, 107 x 107 x 57 mm	51
One-gang box PERILEX®, Depth 50 mm	90	Potential equalisation casing 16 ² with cover, 238 x 208 x 68 mm	51
One-gang box PERILEX®, Depth 50 mm, halogen-free	90	Prefix® 2.0 concrete construction box 1x1	204
One-gang box sound insulation 68	134	Prefix® 2.0 concrete construction box 2x1 NUP	204
One-gang box sound insulation 68 halogen-free	134	Prefix® 2.0 concrete construction box 3x1 NUP	204
One-gang box with device screws, Depth 46 mm	25	Prefix® concrete construction box 1x1 / Ø 30 mm	204
One-gang box without support, Depth 42 mm	34	Prefix® concrete construction box Ø 35 mm	175
One-gang box without support, with device screws, Depth 42 mm	34	Prefix® concrete construction box Ø 60 mm	175
One-gang box, Depth 35 mm	89	Prefix® four-piece assembly kit	254
One-gang box, Depth 35 mm, halogen-free	89	Prefix® two-piece assembly kit	254
One-gang box, Depth 46 mm	25	Prefix® universal support	234
One-gang junction box - ECON® Iso +	79	Prefix® wing set, 12 pieces for AGRO inlet box 9902.xx	196/203
One-gang junction box ECON® 15, air-tight, Depth 66 mm	28	Prefix® wing set, 4 pieces for AGRO inlet box 9902.xx	196/203
One-gang junction box ECON® 15, air-tight, with device screws, Depth 66 mm	28	Primer 250 ml, solvent-free	129
One-gang junction box ECON® Styro 55	77	PROFI countersink hole cutter Ø 68 mm for flush-mounting box installation	387
One-gang junction box Flat 45	239	PROFI countersink hole cutter Ø 74 mm for flush-mounting box installation	387
One-gang junction box for nailing, Depth 63 mm	34	PROFI cutter head Ø 68 mm with ejector spring	387
One-gang junction box for nailing, with device screws, Depth 63 mm	34	PROFI cutter head Ø 68 mm without ejector spring	387
One-gang junction box for solid wood	113/119	PROFI cutter head Ø 74 mm with ejector spring	387
One-gang junction box for thin boardings, depth 61 mm	92		
One-gang junction box for thin panelling, depth 61 mm, halogen-free	92		
One-gang junction box HWD B15	292		
One-gang junction box sound insulation 68	134		
One-gang junction box sound insulation 68 halogen-free	134		
One-gang junction box with side cavities for connections	25		
Optical termination outlet (OTO), partial equipped	344/346		
Optical termination outlet (OTO), ready to splice with pre-assembled cable, 2x fibres	349/352/354		
Optical termination outlet (OTO), splice ready	344		

PROFI cutter head Ø 74 mm without ejector spring	387	Screened junction casing 107 x 107 x 53 mm	43/143
PROFI cutter Ø 68 mm with countersink hole cutter and holder for centering drill	386	Screened one-gang box	143
PROFI cutter Ø 74 mm with countersink hole cutter and holder for centering drill	386	Screened one-gang box / one-gang junction box	143
Prefix distance cutter with dust extraction	394	Screened one-gang junction box	43
PROTECT® one-gang junction box	287	Screw box, Lengths 15/25/40 mm	48
Protecting cover suitable for combination box „the green one“	82	Screw-in cover	171
Protective covers	194	Screw-on cover (330 x 120 x 5 mm) for Art. No. 9914.10	191/230
Punch bit inserts for punch pliers	403	Screwed-on cover	194/206
Punch pliers	402	Screwed-on covers	194
Push-on cover Ø 60 mm	207	Screws	146
Push-on cover with central fixing, RAL 9010	170	Sealing foil	116
Push-on cover with corner fixing, RAL 9010	170	Sealing identification tag DE/GB/FR/IT	302
Push-on cover with diagonal support option, RAL 9010	170	Sealing identification tag DE/GB/FR/NL	302
Push-on covers	195	Sealing inserts	31/116
Q		Sealing plug ECON® M16	33/117/302
Q-range ECON® one-gang box with 4 screw domes	80	Sealing plug ECON® M20	33/117/302
Q-range® one-gang box with 2 device screws, 60 x 60 x 50 mm	80	Sealing plug ECON® M25	33/117/302
Q-range® one-gang box with 2 device screws, 60 x 60 x 65 mm	80	Sealing plug ECON® M32	33/117/302
Q-range® one-gang box, 60 x 60 x 50 mm	80	Sealing plug ECON® M40	33/117/302
Q-range® one-gang box, 60 x 60 x 65 mm	80	Sealing screw, Length 15 mm	48/146
Q-signal® for installation opening 70 x 64 mm	81	Sealing screw, Length 40 mm	48/146
Q-up® plaster compensation ring	81	Separator wall	150/205
Quick ejector adapter for PROFI and EXPERT cutter heads	391	Separator wall for casing size 107 x 107 mm	51
Quick ejector set with PROFI or EXPERT cutter	390	Separator wall for casing size 159 x 159 mm	51
Quick ejector shaft	391	Separator wall for casing size 238 x 208 mm	51
Quickbox® 1x1	153/154	Separator wall for casing size 240 x 142 mm	51
Quickbox® 2x1	154	Separator wall for casing size 87 x 87 mm	51
Quickbox® 3x1	154	Set of 2 Prefix® wing brackets	196
Quickbox® ECON Pro 1x1	154	Setting tool O-range ECON® Fix	108
Quickbox® ECON Pro 2x1	154	Signal cover 100 x 100 mm	46
Quickbox® ECON Pro 3x1	154	Signal cover 80 x 80 mm	46
Quickbox® HWD 90 1x1	305	Signal cover for two-gang junction box	46
Quickbox® HWD 90 2x1	305	Signal cover for wall light connection box	46
Quickbox® HWD 90 3x1	305	Signal cover Ø 35 mm	46/183
Quickbox® Kombi 2x1	153	Signal cover Ø 60 mm	46
Quickbox® Kombi 2x2	153	Signal cover Ø 68 mm for HaloX®	255/264
Quickbox® Kombi 3x1	153	Signal cover Ø 70 mm	46
Quickbox® Kombi 3x2	153	Signal cover Ø 75 mm for HaloX®	255/264
Quickbox® Maxi 1x1	155	Signal cover Ø 80 mm for HaloX®	255/264
Quickbox® Maxi 2x1	155	Signal cover UP ¹ for installation openings Ø 60 mm	23
Quickbox® Maxi 3x1	155	Slide nuts for British accessories	201
Quickbox® Maxi HWD 90 1x1	305	Sound insulation cover for sound insulation box	41/131
Quickbox® Maxi HWD 90 2x2	305	Sound insulation electronics box	132
Quickbox® Maxi HWD 90 3x1	305	Sound insulation electronics box halogen-free	132
Quickbox® Maxi HWD 90 3x2	305	Sound-insulation box	131
R		Sound-insulation box 68 Flex	135
Radiation protection one-gang junction box	139/141	Spacer	273
Reamer	403	SPECIAL cutter ETICS Ø 20 x 80 mm	384
Replacement cover	51/149	SPECIAL cutter ETICS Ø 68 x 180 mm	385
Replacement cover 145 x 75 mm	89	SPECIAL cutter MDF Ø 68 mm	395
Replacement mineral fibreboard for HaloX® 100	253	SPECIAL cutter METAL Ø 68 mm with holder and centering drill	395
Replacement mineral fibreboard for HaloX® 180	253/265	SPECIAL cutter METAL Ø 74 mm with holder and centering drill	395
Replacement mineral fibreboard for HaloX® 250	253/265	Speedy formwork protector - excluding nails	188
S		Speedy formwork protector - including nails	188
Saw blade for standard cutter	397	Spirit level cover	382
Screened cover	43/143	Standard cutter	397
		Step drill	403
		Stepless plaster compensation frame UP ¹	22

Service

Item overview

Styrofoam moulded parts	256	Universal installation housing with mineral fibreboard cover	197/198
Support connector	57/96/131/139/141/285	Universal installation housing with mineral fibreboard, 107 x 107 x 72 mm	53
Support connector, air tight	96/114	Universal installation housing with mineral fibreboard, 159 x 159 x 90 mm	53
Support connector, air-tight, halogen-free	96/114/131/282	Universal installation housing with mineral fibreboard, 238 x 208 x 83 mm	53
Support connector, halogen-free	96	Universal installation housing with mineral fibreboard, 240 x 142 x 102 mm	53
Support element Ø 20 mm	173	Universal installation housing with mineral fibreboard, 240 x 280 x 102 mm	53
Synthetic cable glands Progress® GFK for installation of multiple cables	366	Universal installation housing with mineral fibreboard, 87 x 87 x 75 mm	53
Synthetic cable glands Syntec® with lamellar technology	361/362	Universal mounting plate	310
Synthetic lock nuts with flange	367	Universal opening cutter for plastics	401
Synthetic locking plugs	368	Universal VDE cover	47/115/205
Synthetic Syntec® cable glands with lamellar technology and anti-kink nozzle	363	Universal VDE cover, halogen-free	47/115/205
System equipment carrier 160 - 240 mm with universal mounting plate	65	Universal-waterproof cover Ø 90 mm, Screw spacing 60 mm	47/115/205
System equipment carrier 160-240 mm with multiple accessory insert for boxes	65	Universal-waterproof cover Ø 90 mm, Screw spacing 67 mm	47/115/205
System equipment carrier 240 - 310 mm with multiple accessory insert for boxes	65	UP ¹ ECON® Fix electronics box	21
System equipment carrier 240 - 310 mm with universal mounting plate	65	UP ¹ ECON® Fix one-gang box	19
System magnet	212/264	UP ¹ ECON® Fix one-gang junction box	19
System magnet adapter for the inclined support attachment	225	UP ¹ ECON® Fix two-gang junction box	21
System magnet PLUS	213/264	Upper frame (308 x 98 x 45 mm) for Art. No. 9914.10	191/230
T		V	
Telescope equipment carrier	71	VARIOCUT universal hole cutter for cavity wall building materials	398
Telescope switch box	71	W	
Telescopic support	199	Wall and ceiling elbow 30°	185
ThermoX® Decorative coverings	272	Wall and ceiling transition 90° for M20 conduits	236
ThermoX® housing for low and high-voltage luminaires	271	Wall and ceiling transition 90° for M25 conduits	236
ThermoX® individual front rings	272	Wall and ceiling transition for M25 conduits, without special adhesive	235
ThermoX® LED housing	267	Wall groove clip	46
ThermoX® universal front ring	272	Wall light connection box	38
ThermoX® universal housing with mineral fibreboard	272	Wall light connection box Flat 45	239
Tubing stand with hook	189	Wall light connection box with cover, air tight, Depth 45 mm	94/114
Tunnel connector	47	Wall light connection box with cover, air tight, Depth 45 mm, halogen-free	94/114
Twist drill	397/399	Wall light connection box with cover, Depth 40	94
Two-gang junction box	33	Waterproof cover	171/195
Two-gang junction box ECON®, air-tight	30	Wire-pull casing	193
Two-gang junction box with device screws	33		
Two-gang junction box, Depth 47 mm	89		
Two-gang junction box, Depth 47 mm, halogen-free	89		
U			
Universal equipment carrier	59		
Universal equipment carrier with combination insert	61		
Universal extension element 105 to 170 mm for glueing	224		
Universal extension element 105 to 170 mm for push-button fixing	224		
Universal extension element 175 to 300 mm for glueing	224		
Universal extension element 175 to 300 mm for push-button fixing	224		
Universal installation housing	198		
Universal installation housing with mineral fibreboard	152		

PG	Price group designation
110	Basic range
120	Flush-mounting / Cavity wall
130	On-site mixed concrete
140	Pre-cast concrete in concrete construction
150	Installation housing concrete construction
160	Drywall installation housing
170	Tools
180	Energy efficiency

PG	Price group designation
190	Fire protection, noise protection, radiation protection
200	Pluggable installation
250	Surface-mounting
540	KV Progress Various
550	KV SyntecMS
560	KV SyntecPlastic
730	Connectivity / fibre-optic broadband expansion

Art. No.	Page	PG	Art. No.	Page	PG	Art. No.	Page	PG
10...			1068-02	26	120	1083-85	391	170
10100	206	130	1068-21	30	180	1083-99	387	170
1040-01	31/116	180	1068-26	21	180	1084-20	396	170
1040-16	33/117/302	180	1069-02	25	120	1084-35	396	170
1040-20	33/117/302	180	1075-04	35	120	1084-74	396	170
1040-25	33/117/302	180	1076-04	35	120	1084-79	396	170
1040-32	33/117/302	180	1076-20	83	120	1084-83	154/396	170
1040-40	33/117/302	180	1081-05	37	120	1084-86	396	170
1045.12.050	365	550	1081-10	386	170	1085-09	397	170
1045.12.070	365	550	1081-11	387	170	1085-68	395	170
1045.17.060	365	550	1081-12	387	170	1085-80	401	170
1045.17.100	365	550	1081-15	387	170	1085-99	394	120
1045.20.080	365	550	1081-20	386	170	1086-00	397	170
1045.20.130	365	550	1081-21	387	170	1086-08	397	170
1045.25.110	365	550	1081-22	387	170	1086-09	397	170
1045.25.170	365	550	1081-25	387	170	1086-30	397	170
1045.32.150	365	550	1082-30	388	170	1086-68	395	170
1045.32.210	365	550	1082-31	389	170	1086-74	395	170
1045.40.230	365	550	1082-32	389	170	1087-08	397	170
1045.40.280	365	550	1082-35	389	170	1087-09	397	170
1045.50.290	365	550	1082-40	388	170	1088-00	380	170
1045.50.350	365	550	1082-41	389	170	1088-01	380	170
1045.63.390	365	550	1082-42	389	170	1088-02	379	170
1045.63.480	365	550	1082-45	389	170	1088-03	379	170
1048-00	38	120	1083-25	394	170	1088-06	384	170
1050-00	34	120	1083-27	394	170	1088-07	385	170
1051-00	34	120	1083-28	394	170	1088-15	380	170
1055-04	25	110	1083-29	394	170	1088-16	379	170
1055-21	28	110	1083-40	389	170	1088-20	380	170
1055-26	19	120	1083-41	389	170	1088-21	379	170
1055-62	34	120	1083-50	389	170	1088-30	380	170
1056-04	25	110	1083-60	389	170	1088-40	380	170
1056-21	28	180	1083-80	390	170	1088-41	379	170
1056-62	34	120	1083-81	391	170	1088-50	393	170

FLUSH-MOUNTING

CAVITY WALL

CONCRETE

HOUSINGS

FIRE PROTECTION

PLUGGABLE

CONNECTIVITY

CABLE GLANDS

TOOLS

SERVICE

Service

Item number directory

Art. No.	Page	PG	Art. No.	Page	PG	Art. No.	Page	PG
1089-00	398	170	1145.40.230	365	550	1190-55	381	170
1089-02	398	170	1145.40.280	365	550	1190-60	382	170
1089-30	399	170	1145.50.290	365	550	1190-65	381	170
1089-31	399	170	1145.50.350	365	550	12...		
1089-33	399	170	1145.63.390	365	550	1200-00	201	130
1089-34	399	170	1145.63.480	365	550	1200-99	225	-
1089-92	399	170	1145.63.550	365	550	1202-04	185	130
1090-12	108	170	1148-90	38/94	120	1202-29	185	130
1090-22	385	170	1148-93	207	130	1202-34	185	130
1090-68	385	170	1155-61	47	120	1203-28	185	130
1092-20	51	120	1155-62	47	120	1204-24	184	130
1092-27	53	120	1155-65	22	120	1204-29	184	130
1092-28	53	120	1155-71	47	120	1204-34	184	130
1092-90	50	120	1155-72	47	120	1205-02	173	130
1092-93	51/149	120	1155-95	23	120	1210-02	173	130
1092-95	51	120	1158-90	115	120	1211-00	167/187	130
1094-01	49	120	1159-03	45	120	1211-01	175	130
1094-13	51	120	1159-12	45	120	1211-02	175	130
1094-20	51	120	1159-24	59	180	1211-20	186	130
1094-22	53	120	1159-25	48	110	1211-25	187	130
1094-91	49	120	1159-26	61	180	1211-32	187	130
1095-01	50	120	1159-27	59/61	180	1212-04	173	130
1095-13	51	120	1159-34	46	120	1212-06	173	130
1095-20	51	120	1159-36	47	120	1212-08	173	130
1095-22	53	120	1159-50	74	180	1212-10	173	130
1095-73	51	120	1159-55	79	180	1212-12	173	130
1095-91	50	120	1159-60	71	180	1212-14	173	130
1095-93	51/149/205	120	1159-61	71	180	1212-16	173	130
1096-01	50	120	1159-62	71	180	1212-18	173	130
1096-13	51	120	1159-70	68	180	1212-20	173	130
1096-20	51	120	1159-71	68	180	1212-98	173	130
1096-22	53	120	1159-90	57	180	1212-99	173	130
1096-91	50	120	1159-91	57	180	1217-02	207/240	130
1096-93	51/149/205	120	1159-95	46	120	1219-00	171	140
1097-22	51	120	1164-88	43/143	120	1219-10	399	170
1097-28	53	120	1172-02	36	110	1223-22	197	130
1097-75	51	120	1172-09	37	120	1223-41	200	130
1097-92	50	120	1172-62	36	120	1224-22	197	130
1097-93	51/149/205	120	1172-92	36	120	1224-41	200	130
11...			1174-25	48	110	1224-99	201	130
11022	189	130	1174-98	47/115/205	120	1225-10	182	130
11081	206	130	1174-99	47/115/205	120	1225-12	182	130
11082	206	130	1181-35	46/183	120	1225-14	182	130
11088	206	130	1181-48	46	120	1225-30	182	130
1144-00	38	120	1181-56	46	120	1225-40	182	130
1144-05	38	120	1181-60	46	110	1225-60	182	130
1145.12.050	365	550	1181-65	23	120	1225-80	182	130
1145.12.070	365	550	1181-70	46	120	1226-30	180	130
1145.17.060	365	550	1181-94	46	120	1226-55	95/180	130
1145.17.100	365	550	1181-95	46	120	1226-65	95/180	130
1145.20.080	365	550	1184-25	48	120	1226-75	180	130
1145.20.130	365	550	1184-69	41/131	190	1226-85	180	130
1145.25.110	365	550	1184-77	47/115/205	120	1226-95	180	130
1145.25.170	365	550	1184-90	47/115/205	120	1226-97	180/227	130
1145.32.150	365	550	1184-94	289	190	1226-98	180/227	130
1145.32.210	365	550	1190-02	401	170	1226-99	180/227	130

Art. No.	Page	PG	Art. No.	Page	PG	Art. No.	Page	PG
1227-16	226	130	1262-60	216	140	1281-68	251	150
1227-50	179	130	1262-61	215	140	1281-69	251	150
1227-54	227	130	1263-06	215	140	1282-00	249	150
1227-55	227	110	1263-32	219	140	1282-01	252	150
1245-62	182	130	1263-60	216	140	1282-02	252	150
1245-63	182	130	1263-61	215	140	1282-03	252	150
1246-01	239	130	1264-06	215	140	1282-04	252	150
1247-01	180	130	1264-60	216	140	1282-05	252	150
1248-01	162	130	1264-61	215	140	1282-06	252	150
1248-03	163	130	1265-01	161	130	1282-10	252	150
1248-55	38	130	1265-11	177	130	1282-11	252	150
1249-11	177	130	1265-12	177	130	1282-25	254/265	150
1249-12	177	130	1265-13	179	130	1282-27	253/265	150
1249-13	178	130	1266-01	239	130	1282-30	249	150
1255-01	161	130	1266-25	220	140	1282-40	249	150
1255-43	163	130	1268-01	166	130	1282-50	254/265	150
1256-01	239	130	1269-01	166	130	1282-61	252	150
1256-08	240	130	1269-03	201	130	1282-62	252	150
1256-12	240	130	1269-04	201	130	1282-63	252	150
1259-04	166	130	1270-00	207	130	1282-64	252	150
1259-96	207	130	1273-43	189	130	1282-65	252	150
1260-01	162	130	1273-44	189	130	1282-66	252	150
1260-11	178	130	1273-45	189	130	1282-71	262	150
1261-00	234	140	1275-40	164	130	1282-72	262	150
1261-02	222	140	1276-40	164	130	1282-73	262	150
1261-06	224	140	1276-70	164	130	1282-74	263	150
1261-07	224	140	1276-71	164	130	1282-75	263	150
1261-08	224	140	1281-00	249	150	1282-76	263	150
1261-09	224	140	1281-01	250	150	1283-00	249	150
1261-10	223	140	1281-02	250	150	1283-01	253	150
1261-11	223	140	1281-03	250	150	1283-02	253	150
1261-12	235	140	1281-04	250	150	1283-03	253	150
1261-14	236	140	1281-05	250	150	1283-04	253	150
1261-16	236	140	1281-06	250	150	1283-05	253	150
1261-18	216	140	1281-07	250	150	1283-06	253	150
1261-21	218	140	1281-08	251	150	1283-10	253	150
1261-26	218	140	1281-09	251	150	1283-11	253	150
1261-32	218	140	1281-10	251	150	1283-25	254/265	150
1261-40	218	140	1281-11	251	150	1283-27	253/265	150
1261-42	237	140	1281-15	250	150	1283-33	188	130
1261-43	237	140	1281-20	258	150	1283-34	188	130
1261-60	216	140	1281-21	254/258/259	150	1283-40	249	150
1261-81	213/240	140	1281-25	254/259	150	1283-50	254/265	150
1261-82	232	140	1281-27	253	150	1283-61	253	150
1261-83	232	140	1281-30	249	150	1283-62	253	150
1261-84	232	140	1281-31	255/264	150	1283-63	253	150
1261-92	233	140	1281-32	255/264	150	1283-64	253	150
1261-93	233	140	1281-33	255/264	150	1283-65	253	150
1261-94	233	140	1281-50	254/259	150	1283-66	253	150
1261-95	233	140	1281-61	250	150	1283-71	262	150
1261-96	233	140	1281-62	250	150	1283-73	262	150
1261-97	233	140	1281-63	250	150	1283-74	263	150
1262-06	215	140	1281-64	250	150	1283-76	263	150
1262-20	220	140	1281-65	250	150	1284-32	403	170
1262-25	220	140	1281-66	250	150	1284-34	403	170
1262-32	220	140	1281-67	250	150	1284-35	403	170

FLUSH-MOUNTING
CAVITY WALL
CONCRETE
HOUSINGS
FIRE PROTECTION
PLUGGABLE
CONNECTIVITY
CONNECTIONS
CABLE GLANDS
TOOLS
SERVICE

Service

Item number directory

Art. No.	Page	PG	Art. No.	Page	PG	Art. No.	Page	PG
1284-36	403	170	1546.20.07	363	560	1571.32.6.070	366	510
1284-62	402	170	1546.20.12	363	560	1572-02	37	120
1284-63	402	170	1550-00	35	120	1576.12.06	363	560
1284-68	402	170	1551-00	35	120	1576.17.08	363	560
1284-69	402	170	1555-04	25	110	1576.20.07	363	560
1285-33	403	170	1555-21	28	110	1576.20.12	363	560
1285-34	403	170	1555-26	19	120	16...		
1286-33	402	170	1555-51	77	180	1655-02	33	120
1286-34	402	170	1555-62	34	120	1656-02	33	120
1290-30	259	150	1555-88	43	120	1656-21	30	180
1292-90	256	-	1555.12.06	361	560	1656-26	21	180
1295-02	168/201	130	1555.12.1.06	362	560	20...		
1295-22	197	130	1555.17.06	361	560	2000-00	374	120
1295-73	169	130	1555.17.1.06	362	560	2000-80	375	120
1296-02	168	130	1555.17.1.10	362	560	2000-90	375	120
1296-20	205	130	1555.17.10	361	560	24...		
1296-22	198	130	1555.20.08	361	560	2444-15	48/146	120
1297-02	168	130	1555.20.1.08	362	560	2444-40	48/146	120
1297-20	205	130	1555.20.1.13	362	560	2445-25	146	120
1297-22	198	130	1555.20.13	361	560	2445-50	146	120
1297-34	198	130	1555.25.1.11	362	560	2472-15	48/146	120
1297-35	198	130	1555.25.1.17	362	560	2472-20	48/146	120
1297-75	169	130	1555.25.11	361	560	2472-25	48/146	120
1298-37	198	130	1555.25.17	361	560	2472-40	48/146	120
1298-38	198	130	1555.32.1.25	362	560	2472-91	48	120
1299-60	254	150	1555.32.25	361	560	25...		
1299-61	254	150	1555.40.1.33	362	560	2521	317	250
1299-62	254	150	1555.50.1.38	362	560	42...		
1299-63	254	150	1555.63.1.44	362	560	4240001	335	730
1299-64	254	150	1556-04	25	110	4250001	346	730
1299-65	254	150	1556-21	28	180	4250002	346	730
1299-66	254	150	1556-62	34	120	4250005	354	730
1299-69	212/264	140	1564-01	278	190	4250006	354	730
1299-70	213/264	140	1569-01	41	190	4250007	354	730
15...			1571.17.2.030	366	510	4250008	354	730
1545.12.06	361	560	1571.17.2.040	366	510	4250009	354	730
1545.12.1.06	362	560	1571.17.2.050	366	510	4250010	354	730
1545.17.06	361	560	1571.20.2.050	366	510	4250011	354	730
1545.17.1.06	362	560	1571.20.2.060	366	510	4250012	355	730
1545.17.1.10	362	560	1571.20.2.075	366	510	4250013	355	730
1545.17.10	361	560	1571.20.3.050	366	510	4250014	355	730
1545.20.08	361	560	1571.20.3.060	366	510	4250015	355	730
1545.20.1.08	362	560	1571.20.3.065	366	510	4250016	355	730
1545.20.1.13	362	560	1571.20.4.050	366	510	4250017	355	730
1545.20.13	361	560	1571.20.4.060	366	510	4250018	355	730
1545.25.1.11	362	560	1571.25.2.070	366	510	4250019	330	730
1545.25.1.17	362	560	1571.25.2.090	366	510	4250020	330	730
1545.25.11	361	560	1571.25.2.100	366	510	4250021	330	730
1545.25.17	361	560	1571.25.3.070	366	510	4250022	330	730
1545.32.1.25	362	560	1571.25.3.090	366	510	4250023	330	730
1545.32.25	361	560	1571.25.4.070	366	510	4250024	329	730
1545.40.1.33	362	560	1571.25.6.060	366	510	4250025	329	730
1545.50.1.38	362	560	1571.32.2.115	366	510	4250026	329	730
1545.63.1.44	362	560	1571.32.3.090	366	510	4250027	329	730
1546.12.06	363	560	1571.32.3.105	366	510	4250028	329	730
1546.17.08	363	560	1571.32.4.090	366	510	4250029	333	730

Art. No.	Page	PG	Art. No.	Page	PG	Art. No.	Page	PG
4250030	333	730	4250086	332	730	4252048	327	730
4250031	333	730	4250087	332	730	4252049	326	730
4250032	333	730	4250088	332	730	4252050	326	730
4250033	333	730	4250089	332	730	4252051	326	730
4250034	332	730	4250090	332	730	4252052	326	730
4250035	332	730	4250091	332	730	4252053	326	730
4250036	332	730	4250092	332	730	4252054	324	730
4250037	332	730	4250093	332	730	4252055	324	730
4250038	332	730	4250094	332	730	4252056	324	730
4250039	330	730	4252001	344	730	4252057	324	730
4250040	330	730	4252002	344	730	4252058	324	730
4250041	330	730	4252003	344	730	4252059	324	730
4250042	330	730	4252004	344	730	4252060	324	730
4250043	330	730	4252005	344	730	4252061	324	730
4250044	330	730	4252006	349	730	4252062	324	730
4250045	330	730	4252007	349	730	4252063	324	730
4250046	330	730	4252008	349	730	4252064	324	730
4250047	330	730	4252009	349	730	4252065	324	730
4250048	330	730	4252010	349	730	4252066	324	730
4250049	330	730	4252011	349	730	4252067	324	730
4250050	330	730	4252012	349	730	4252068	323	730
4250051	330	730	4252013	352	730	4252069	323	730
4250052	330	730	4252014	352	730	4252070	323	730
4250053	329	730	4252015	352	730	4252071	323	730
4250054	329	730	4252016	352	730	4252072	323	730
4250055	329	730	4252017	352	730	4252073	323	730
4250056	329	730	4252018	352	730	4252074	323	730
4250057	329	730	4252019	352	730	4252075	323	730
4250058	329	730	4252020	349	730	4252076	323	730
4250059	329	730	4252021	349	730	4252077	323	730
4250060	329	730	4252022	349	730	4252078	323	730
4250061	329	730	4252023	349	730	4252079	323	730
4250062	329	730	4252024	349	730	4252080	323	730
4250063	329	730	4252025	349	730	4252081	323	730
4250064	329	730	4252026	349	730	4252082	327	730
4250065	329	730	4252027	352	730	4252083	327	730
4250066	329	730	4252028	352	730	4252084	327	730
4250067	333	730	4252029	352	730	4252085	327	730
4250068	333	730	4252030	352	730	4252086	327	730
4250069	333	730	4252031	352	730	4252087	327	730
4250070	333	730	4252032	352	730	4252088	327	730
4250071	333	730	4252033	352	730	4252089	327	730
4250072	333	730	4252034	324	730	4252090	327	730
4250073	333	730	4252035	324	730	4252091	327	730
4250074	333	730	4252036	324	730	4252092	327	730
4250075	333	730	4252037	324	730	4252093	327	730
4250076	333	730	4252038	324	730	4252094	327	730
4250077	333	730	4252039	323	730	4252095	327	730
4250078	333	730	4252040	323	730	4252096	326	730
4250079	333	730	4252041	323	730	4252097	326	730
4250080	333	730	4252042	323	730	4252098	326	730
4250081	332	730	4252043	323	730	4252099	326	730
4250082	332	730	4252044	327	730	4252100	326	730
4250083	332	730	4252045	327	730	4252101	326	730
4250084	332	730	4252046	327	730	4252102	326	730
4250085	332	730	4252047	327	730	4252103	326	730

FLUSH-MOUNTING
CAVITY WALL
CONCRETE
HOUSINGS
FIRE PROTECTION
PLUGGABLE
CONNECTIVITY
CABLE GLANDS
TOOLS
SERVICE

Service

Item number directory

Art. No.	Page	PG	Art. No.	Page	PG	Art. No.	Page	PG
4252104	326	730	8245.25	367	560	9060-41	116	180
4252105	326	730	8245.32	367	560	9060-42	96	120
4252106	326	730	8245.40	367	560	9060-68	285	190
4252107	326	730	8245.50	367	560	9060-74	139	190
4252108	326	730	8245.63	367	560	9060-77	96	120
4252109	326	730	8255.12	367	560	9060-78	96/114/282	180
4261011	338	730	8255.17	367	560	9060-88	57/131/141	190
4264001	334	730	8255.20	367	560	9060-95	207	130
4264002	334	730	8255.25	367	560	9060-97	96	120
4264003	337	730	8255.32	367	560	9060-98	96/114	180
4264004	337	730	8255.40	367	560	9061-00	89	120
4264005	337	730	8255.50	367	560	9061-01	91	120
4264006	337	730	8255.63	367	560	9061-77	89	120
4264007	337	730	87...			9061-78	91	120
4264008	337	730	8745.12	369	550	9062-02	89	120
4264009	337	730	8745.17	369	550	9062-50	94	120
4264010	337	730	8745.20	369	550	9062-74	93/114	180
4264011	337	730	8745.25	369	550	9062-77	89	120
4264012	337	730	8745.32	369	550	9062-90	89	120
4264013	336	730	8745.40	369	550	9062-94	93/114	180
45...			8745.50	369	550	9063-02	88	110
4551	188	130	8745.63	369	550	9063-50	95	120
4551.14	188	130	88...			9063-78	88	120
4552	188	130	8845.12	368	560	9063-88	143	120
4555	189	130	8845.17	368	560	9064-02	88	110
4558	188	130	8845.20	368	560	9064-78	88	120
4560	189	130	8845.25	368	560	9064-88	143	120
4561	189	130	8845.32	368	560	9066-01	112	180
50...			8845.40	368	560	9066-12	113	180
5000	102	120	8845.50	368	560	9066-77	112	180
54...			8845.63	368	560	9067-01	90	120
5431	304	190	8855.12	368	560	9067-77	90	120
5439	304	190	8855.17	368	560	9068-01	112	180
66...			8855.20	368	560	9068-03	92	120
662	83	120	8855.25	368	560	9068-04	92	120
663	83	120	8855.32	368	560	9068-74	92	120
75...			8855.40	368	560	9068-76	92	120
7500	80	120	8855.50	368	560	9068-79	112	180
7501	80	120	8855.63	368	560	9068-88	143	120
752	80	180	90...			9068-94	135	190
76...			9000-02	129	180	9069-01	131	190
7650	80	120	9059-44	124	180	9069-03	134	190
7651	80	120	9059-45	124	180	9069-04	134	190
80...			9059-46	124	180	9069-94	132	190
8000.12	369	540	9059-47	124	180	9071-01	90	120
8000.17	369	540	9059-48	124	180	9071-77	90	120
8000.20	369	540	9059-49	124	180	9073-01	148	120
8000.25	369	540	9059-51	124	180	9073-20	150	120
8000.32	369	540	9059-52	124	180	9073-78	148	120
8000.40	369	540	9059-53	124	180	9073-79	149	120
8000.50	369	540	9059-54	124	180	9073-93	149	120
8000.63	369	540	9059-55	124	180	9074-01	139	190
82...			9059-56	124	180	9074-03	141	190
8245.12	367	560	9059-61	126	180	9075-01	90	120
8245.17	367	560	9059-62	126	180	9075-12	113	180
8245.20	367	560	9060-40	96	120	9075-77	90	120

Art. No.	Page	PG	Art. No.	Page	PG	Art. No.	Page	PG
9075-78	113	180	9197-77	148	120	94...		
9079-44	128	180	9197-91	148	120	9400-05	281	190
9079-45	128	180	92...			9435-03	303	190
9079-46	128	180	9248-01	94/114	120	9435-04	303	190
9079-47	128	180	9248-77	94/114	120	9459-01	297	190
9079-48	128	180	9252-22	101	180	9459-02	297	190
9079-49	128	180	9252-78	101	180	9459-03	298	190
9079-51	128	180	9253-22	101	180	9459-04	299	190
9079-52	128	180	9253-78	101	180	9459-05	300	190
9079-53	128	180	9254-22	102	180	9459-06	301	190
9079-54	128	180	9254-78	102	180	9459-14	293	190
9079-55	128	180	9261-20	121	180	9459-15	293	190
9079-56	128	180	9261-25	121	180	9461-14	291	190
9089-44	127	180	9263-22	99	110	9462-94	283	190
9089-45	127	180	9263-78	99	180	9463-01	282	190
9089-46	127	180	9264-12	108	180	9463-03	285	190
9089-47	127	180	9264-22	99	110	9463-14	291	190
9089-48	127	180	9264-32	137	180	9463-15	291	190
9089-49	127	180	9264-42	145	180	9463-50	289	190
9089-51	127	180	9264-72	108	180	9464-01	282	190
9089-52	127	180	9264-78	99	180	9464-03	285	190
9089-53	127	180	9266-22	103	180	9464-05	287	190
9089-54	127	180	9266-77	103	180	9464-14	292	190
9089-55	127	180	9268-74	109	180	9464-15	292	190
9089-56	127	180	9268-94	109	180	9464-50	289	190
9098-77	153	120	9273-50	106	180	9473-91	302	190
9098-77.02	153	120	9273-78	104	180	9473-92	302	190
9098-77.03	153	120	9273-92	104	180	9473-95	301	190
9098-77.04	153	120	9274-22	119	180	9473-96	301	190
9098-77.06	153	120	9280-22	111	180	9498-77	305	190
91...			9280-78	111	180	9498-77.02	305	190
9148-00	94	120	9299-77	154	180	9498-77.03	305	190
9155-61	96	120	9299-77.02	154	180	9499-77	305	190
9155-62	96	120	9299-77.03	154	180	9499-77.02	305	190
9155-71	96	120	93...			9499-77.03	305	190
9155-72	96	120	9300-01	271	160	9499-77.04	305	190
9192-20	150	120	9300-02	271	160	9499-77.06	305	190
9192-22	152	120	9300-03	271	160	97...		
9192-27	152	120	9300-22	272	160	975	81	120
9192-77	148	120	9300-41	272	160	9798-77	154	190
9192-91	148	120	9300-42	272	160	9798-77.02	154	190
9195-20	150	120	9300-43	272	160	9798-77.03	154	190
9195-22	152	120	9300-93	272	160	9799-77	155	190
9195-27	152	120	9301-01	272	160	9799-77.02	155	190
9195-73	149	120	9301-02	272	160	9799-77.03	155	190
9195-77	147	120	9301-03	272	160	99...		
9195-88	43/143	120	9301-11	272	160	99.1234	82	120
9195-91	147	120	9301-12	272	160	99.1234.06	82	120
9196-20	150	120	9301-13	272	160	9902.22	202	130
9196-22	152	120	9310-10	273	160	9902.23	202	130
9196-27	152	120	9320-10	267	160	9902.24	203	130
9196-77	147	120	9320-11	267	160	9902.24.40	202	130
9196-91	147	120	9320-20	267	160	9902.26	203	130
9197-20	150	120	9320-21	267	160	9902.28	203	130
9197-22	152	120	9350-21	269	160	9902.29	203	130
9197-27	152	120	9350-99	269	160	9907	170	130

FLUSH-MOUNTING
CAVITY WALL
CONCRETE
HOUSINGS
FIRE PROTECTION
PLUGGABLE
CONNECTIVITY
CABLE GLANDS
TOOLS
SERVICE

Service

Item number directory

Art. No.	Page	PG	Art. No.	Page	PG	Art. No.	Page	PG
9907.21	170	130	9918	202	130	AT2251	309	200
9907.68	170	130	9921	81	120	AT2252	309	200
9907.68.45	170	130	994	81	120	AT2254	313	200
9908.01	169	130	9940	204	130	AT2256	309	200
9908.01.850	82	130	9940.20	196	130	AT2257	315	200
9908.21	169	130	9940.25	196/203	130	AT2258	308	200
9908.68	83/170	130	9940.50	196/203	130	AT2264	309	200
9908.68.45	83	130	9941	204	130	AT2274	313	200
9909.01	169	130	9941.25	204	130	AT2275	312	200
9909.01.850	82	130	9941.35	204	130	AT2276	312	200
9909.02 S	171	130	9951	182	130	AT2277	312	200
9909.03	171	130	9955	183	130	AT2278	312	200
9909.10	170	130	9957	199	130	AT2289	312	200
9909.12	170	130	9959	181	130	AT2293	313	200
9909.20	170	130	9966.21	65	180	AT2297	312	200
9909.22	170	130	9966.22	65	180	AT2304	312	200
9911.01	192	130	9966.31	65	180	AT2306	312	200
9911.02	194	130	9966.32	65	180	AT29231	357	720
9911.03	195	130	AT...			AT29235	357	720
9911.12	195	130	AT1032	241	130	AT29236	357	720
9912.01	192	130	AT1036	241	130	AT6021	310	200
9914.01	192	130	AT1960	314	200	AT6031	310	200
9914.02	194	130	AT1961	314	200	AT6041	310	200
9914.03	195	130	AT1963	314	200	AT6061	310	200
9914.10	191/230	130	AT1964	315	200	AT6328	316	200
9914.10.02	191/230	130	AT1965	315	200	AT6504	316	200
9914.10.03	191/230	130	AT1966	315	200	AT6510	316	200
9914.10.68	191/230	130	AT1976	315	200	AT7703	310	200
9916	193	130	AT1977	315	200	AT7705	310	200
9916.02	194	130	AT2215	310	200	AT7706	310	200
9916.03	195	130	AT2216	308	200	AT7708	310	200
9916.06	194	130	AT2218	313	200	AT7739	316	200
9916.21	193	130	AT2219	313	200	AT7746	316	200
9916.68	194	130	AT2228	310	200	AT7752	316	200
9917	193	130	AT2229	308	200			
9917.02	194	130	AT2238	313	200			
9917.03	195	130	AT2239	313	200			
9917.06	194	130	AT2244	310	200			
9917.21	193	130	AT2249	310	200			
9917.68	194	130	AT2250	309	200			

To ensure that you can rely on both our **guaranteed product quality** and our delivery promise, both us and our subsidiaries are members of many relevant associations and co-operations. With an international network of partnerships, we always know what the market demands.

The German **Broadband Association (Bundesverband Breitbandkommunikation e.V. / BREKO)** represents the majority of all alternative fixed broadband network operators in Germany. Its members pave the way for future-proof fibre infrastructure and currently account for 80 percent of the competitive FTTB/H deployment in Germany.
www.brekoverband.de

The initiative "**Elektromarken. Starke Partner**" (**Electric brands. Strong partners**) of the 17 leading brand manufacturers brings together the reliable competence and proven quality of the German electrical industry. At the very least, this means an incomparable range of high-quality products and services for the electrical trade.
www.elektromarken.de

The initiative **ELEKTRO+** provides objective information for the planning and execution of electrical installations to principals and experts for new installations as well as modernisations.
www.elektro-plus.com

The **Export Initiative Energy Efficiency** was established by the Federal German Government. It supports German providers with exporting products and services in the field of energy efficiency.
www.efficiency-from-germany.info

The **ETIM** association develops and distributes a classification model for the electrical industry in collaboration with renowned enterprises.
www.etim.de

The **Gemeinsame Ausschuss Elektronik im Bauwesen** (Joint Committee for Electronics in Construction) supports the use of data processing in construction with respect to the common language of everyone involved in the construction process.
www.gae.de

VDE - these three letters stand for one of the major European associations for branches and professions in electrical engineering and information technology. An international expert platform for science, standardisation and product testing.
www.vde.com

The **VEG** is the professional association of electrical wholesalers in Germany. The purpose of the association according to its statutes is the protection, perception and promotion of the general idealistic and economic interests of its members.
www.veg.de

The **ZVEH** represents the economic and political interests of approximately 76,000 electrical and information technology companies at the national and international level.
www.zveh.de

Der **ZVEI** ist einer der wichtigsten Industrieverbände Deutschlands. Er vertritt die Interessen einer Hightech-Branche mit einem sehr breit gefächerten und äußerst dynamischen Produktportfolio.
www.zvei.org



FLUSH-MOUNTING

CAVITY WALL

CONCRETE

HOUSINGS

FIRE PROTECTION

PLUGGABLE

CONNECTIVITY

CABLE GLANDS

TOOLS

SERVICE

Confidence from **experience.**

KAISER installation systems leaves ample room for your planning creativity and technical installations of all kinds. KAISER product and system solutions are at home in all types of buildings. architects and planners rely on our product know-how, which is just as innovative, forward-looking and durable as the items in which they perform their function. These decades of experience, as well as the knowledge gained from discussions with users and fabricators, give you the flexibility you need every day for your planning and installation. We give you the security of working with quality products that are further developed in a future-oriented manner parallel to the increasing requirements of the markets and installation habits.





06

08

07

09

KAISER is behind it!

KAISER has been developing and manufacturing high-quality electrical installation products for flush-mounting, cavity wall and concrete installations in Germany since 1904. Accordingly, many innovative ideas and reliable solutions from KAISER can also be found in important national and international buildings.

More about our business areas:

Flush-mounting . Cavity wall . Concrete construction . Installation housings . Earthing cable glands . Tools . Energy efficiency . Fire protection . Sound insulation . Radiation protection . Building . Pluggable installation . Connectivity ... at www.kaiser-elektro.de

01 | **Trialog** | Hilden
©Lioba Schneider / MAY Architectural Design

02 | **Venloer 4711** | Cologne

03 | **Rapunzel Naturkost** | Legau | ©Rapunzel Naturkost

04 | **University Library Gummersbach** |
©Jana Rettke / TH Cologne

05 | **Pergolenviertel Hamburg** | Hamburg
©blrm Architek*innen GmbH, Joshua Delissen

06 | **Wohn- und Gewerbequartier kupa**
Munich | ©Bauwerk

07 | **Hotel am Erzbergerufer** | Bonn | ©Jens Kirchner

08 | **H2 Hotel Düsseldorf City** | Düsseldorf
©www.h-hotels.com

09 | **Ruby Luna** | Düsseldorf | ©Ruby Hotels



As an innovative manufacturer of products and system solutions for professional electrical installation, the KAISER GROUP is now one of the market leaders in Europe. With an international sales network and the subsidiaries AGRO in Switzerland, HELIA in Belgium and Attema in the Netherlands, we are always there for our customers. The close collaboration of the four companies generates considerable synergies from which our partners in the trade, commerce and industry benefit.

Shaping the future **together.**

The KAISER, AGRO, ATTEMA and HELIA brands consistently offer you installation solutions which meet the needs of the market and thereby effectively support you in your daily work. Through their continuous future-oriented product innovations, these four strong brands provide assurance that you are always at the state of the art– today and tomorrow.



KAISER headquarters
Schalksmühle, Germany

With a large network of distribution partners and representatives as well as our clearly structured warehouse logistics, we always guarantee the fastest availability of our products. With our personal advisory service, we always get quickly on site with you – no matter where your project is being built.



Across Europe. Close to you.

AGRO
Hunzenschwil, Switzerland



ATTEMA
Gorinchem, The Netherlands



HELIA
Erembodegem, Belgium



FLUSH-MOUNTING
CAVITY WALL
CONCRETE
HOUSINGS
FIRE PROTECTION
PLUGGABLE
CONNECTIVITY
CABLE GLANDS
TOOLS
SERVICE

Electrical installation agencies

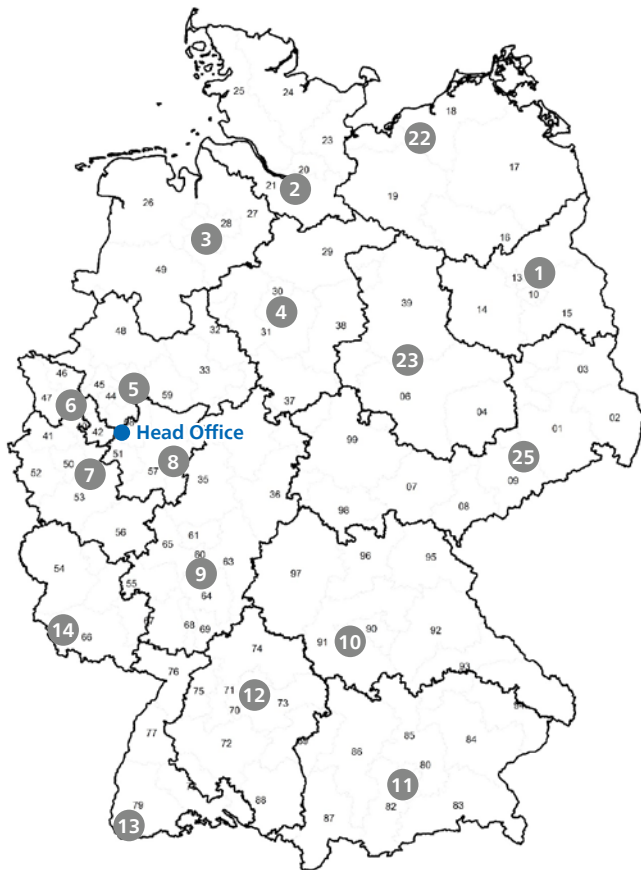

1 **Headquarters**
KAISER GmbH & Co. KG
Ramsloh 4
58579 Schalksmühle,
Germany
Tel.: +49 (0) 23 55 / 809-0
Fax: +49 (0) 23 55 / 809-21
info@kaiser-elektro.de
www.kaiser-elektro.de

3 **Bremen, East Frisia,
Osnabrück**
Steinbeck GmbH
Elektro-Industriervertretung
Carl-Benz-Straße 5
28816 Stuhr, Germany
Tel.: +49 (0) 421 / 874057
Fax: +49 (0) 421 / 875737
info@steinbeck-online.de
www.steinbeck-online.de

1 **Berlin, Brandenburg**
Reiner Brajeska GmbH
Oranienburger Straße 44
16540 Hohen Neuendorf,
Germany
Tel.: +49 (0) 3301 6717-0
Fax: +49 (0) 3301 6717-20
info@brajeska.de
www.brajeska.de

4 **Lower Saxony**
Detlef Sikora GmbH
Lägenfeldstraße 7
30952 Ronnenberg-Empelde,
Germany
Tel.: +49 (0) 511 / 43 80 4-0
Fax: +49 (0) 511 / 43 80 4-49
hannover@sikora.de
www.sikora.de

2 **Hamburg,
Schleswig-Holstein**
Hans J. Möller
Inh. Andreas Möller
Wendenstrasse 195A
20537 Hamburg, Germany
Tel.: +49 (0) 40 / 2514061
Fax: +49 (0) 40 / 2514614
info@hjmoeller.de
www.hjmoeller.de

5 **Westfalia**
dolle & schardt GmbH
Elektro-System-Technik
Bunsenstrasse 10
42551 Velbert, Germany
Tel. +49 (0) 20 51 / 28 06-0
Fax +49 (0) 20 51 / 28 06-29
info@dolle-schardt.de
www.dolle-schardt.de

6 **Essen, Lower Rhine region**
dolle & schardt GmbH
Elektro-System-Technik
Bunsenstrasse 10
42551 Velbert, Germany
Tel.: +49 (0) 20 51 / 28 06-0
Fax: +49 (0) 20 51 / 28 06-29
info@dolle-schardt.de
www.dolle-schardt.de

7 **North Rhine**
Brüning und Kahlen
Industriervertretung GmbH
Methweg 12
50823 Cologne, Germany
Tel.: +49 (0) 221 / 222 881 - 0
Fax: +49 (0) 221 / 222 881 - 50
info@bkiv.de
www.bkiv.de

8 **Olpe / South Westphalia**
Ochsenfeld Handelsagentur
Hagener Straße 6a
57399 Kirchhundem - W. E.,
Germany
Tel.: +49 (0) 2764 / 21 56 9-0
Fax: +49 (0) 2764 / 21 56 9-9
zentrale@ochsenfeld-ha.de
www.ochsenfeld-ha.de

9 **Hessia, Palatinate,
North Baden**
PLP Siegfried Twers
Vertriebs GmbH
Theodor-Heuss-Straße 32
61118 Bad Vilbel, Germany
Tel.: +49 (0) 6101 / 5596 - 0
Fax: +49 (0) 6101 / 5596 - 55
info@plpteam.de
www.plpteam.de

10 **North bavaria**
Jacob Haag Nachf. oHG
Am Farrnbach 5
D-90556 Cadolzburg,
Germany
Tel.: +49 (0) 9103 / 71370-0
Fax: +49 (0) 9103 / 916
info@haag-elektro.de
www.haag-elektro.de

11 **South Bavaria**
Alfons Brummer & Co. GmbH
Felix-Wankel-Strasse 4
82152 Krailling, Germany
Tel.: +49 (0) 89 / 899 968-0
Fax: +49 (0) 89 / 899 968-23
info@brummer.de
www.brummer.de

12 **Württemberg**
Frank Bossert GmbH & Co. KG
Industriervertretungen e.Kfm
Hofener Weg 17
71686 Remseck / Stuttgart,
Germany
Tel.: +49 (0) 7146 / 889 782-60
Fax: +49 (0) 7146 / 889 782-66
info@bossert-weissinger.de
www.bossert-weissinger.de

13 **South Baden**
FRED ABEL GMBH
Vertretungen der
Elektro-Industrie
Im Ebnet 1
79238 Ehrenkirchen, Germany
Tel.: +49 (0) 7633 / 9501-0
Fax: +49 (0) 7633 / 9501-30
info@fredabel.de
www.fredabel.de

14 **Saarland, Trier district,
Kaiserslautern**
Albrecht WERNER GmbH
Elektrotechnik + Service
Am Felsbrunnen 5
66119 Saarbrücken, Germany
Tel.: +49 (0) 681 / 883 55 - 0
Fax: +49 (0) 681 / 883 55 - 55
info@werner-industriervertretung.de
www.werner-industriervertretung.de

22 **Mecklenburg**
Hans J. Möller
Inh. Andreas Möller
Wendenstrasse 195A
20537 Hamburg, Germany
Tel.: +49 (0) 40 / 2514061
Fax: +49 (0) 40 / 2514614
info@hjmoeller.de
www.hjmoeller.de

23 **Saxony-Anhalt,
North Thuringia**
Detlef Sikora GmbH
Gewerbegebiet Süd Nr. 2
39443 Staßfurt, Germany
Tel.: +49 (0) 39266 / 931-0
Fax: +49 (0) 39266 / 931-15
stassfurt@sikora.de
www.sikora.de

25 **Saxony, South Thuringia**
Industriervertretung OTT KG
Am Rossauer Wald 6
09661 Rossau, Germany
Tel.: +49 (0) 37207 / 405-0
Fax: +49 (0) 37207 / 405-33
info@iv-ott.de
www.iv-ott.de

Sales Germany electrical installations

1 23 25 Tel. +49 (0) 23 55 / 809-191
Fax +49 (0) 23 55 / 809-21

2 3 22 Tel. +49 (0) 23 55 / 809-77
Fax +49 (0) 23 55 / 809-42

4 Tel. +49 (0) 23 55 / 809-497
Fax +49 (0) 23 55 / 809-21

10 12 13 Tel. +49 (0) 23 55 / 809-118
Fax +49 (0) 23 55 / 809-21

8 9 14 Tel. +49 (0) 23 55 / 809-121
Fax +49 (0) 23 55 / 809-21

5 6 7 Tel. +49 (0) 23 55 / 809-446
Fax +49 (0) 23 55 / 809-21

11 Tel. +49 (0) 23 55 / 809-801
Fax +49 (0) 23 55 / 809-21

KAISER service numbers

Technical advice electrical installation

Tel. +49 (0) 23 55 / 809-61
technik@kaiser-elektro.de

Technical advice cable glands

Tel. +49 (0) 23 55 / 809-119
kabelverschraubung@kaiser-elektro.de

Technical advice Connectivity

Tel. +49 (0) 23 55 / 809-567
hotline@kaiser-connectivity.de

Sales international

Tel. +49 (0) 23 55 / 809-88 / -115 / -105
Fax +49 (0) 23 55 / 809-40

Sales industry

Tel. +49 (0) 23 55 / 809-254 / -320
Fax +49 (0) 23 55 / 809-21

Sales Connectivity

Tel. +49 (0) 23 55 / 809-497
Fax +49 (0) 23 55 / 809-21

Technical sales

Technical Sales

Tel. +49 (0) 23 55 / 809-320
Tel. +49 (0) 23 55 / 809-164
Tel. +49 (0) 23 55 / 809-254



GERMANY

KAISER GmbH & Co. KG

Ramsloh 4 • 58579 Schalksmühle
GERMANY

Tel. +49 (0) 23 55 / 809-0 • Fax +49 (0) 23 55 / 809-21
www.kaiser-elektro.de • info@kaiser-elektro.de

SWITZERLAND

AGRO AG Member of KAISER GROUP

Korbackerweg 7 • 5502 Hunzenschwil
SWITZERLAND

Tel. +41 (0) 62 / 88947-47 • Fax +41 (0) 62 / 88947-50
www.agro.ch • info@agro.ch

NETHERLANDS

ATTEMA B.V. Member of KAISER GROUP

Schelluinstestraat 1 • 4203 NJ Gorinchem
NETHERLANDS

Tel. +31 (0) 183 / 650-650 • Fax +31 (0) 183 / 650-750
www.attema.com • info@attema.nl

BELGIUM

N.V. PLASTIC COLOR Member of KAISER GROUP

Industrielaan 10 • 9320 Erembodegem
BELGIUM

Tel. +32 (0) 53 / 8505-20 • Fax +32 (0) 53 / 8505-30
www.helia-elektro.be • info@helia-elektro.be

The current terms of delivery and payment terms can be found on our website at: www.kaiser-elektro.de

Solutions and systems for professional installations.

KAISER has been developing and producing systems and products as the basis for professional installation work since 1904. Planners and fitters all over the world use our practice-oriented solutions for their daily work in all installation areas.



Electrical installation.

Innovative, safe and economically viable solutions for a wide range of applications in buildings and ships. They make daily work easier and ensure safe, sustainable installation results in both traditional and pluggable electrical installations.



Connectivity / fibre-optic broadband expansion.

A practical, innovative solution offering for professionals. From street distribution to building distribution to flat distribution, pluggable and pre-assembled, ready-to-splice products are available for efficient installation.



Cable glands / industrial products.

AGRO cable glands made from plastic, brass or stainless steel for the highest quality and practicality. The complete range for trade and industry also includes products with enhanced requirements (EMC, EX), elbow cable glands or universal and multi-cable entries.



Ultima Kft.
Központi raktár: 1172 Budapest, Rétifarkas utca 6.
Telefon: +36 1 432 8820
www.ultima.hu

